

KAYABA



WORLD-CLASS SHOCK ABSORBERS



2004

SHOCK ABSORBERS • STOSSDÄMPFER • AMORTISSEURS • AMMORTIZZATORI • ARMORTIGUADORES

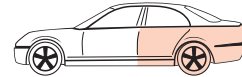
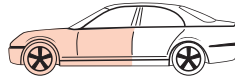

MODEL FAHRZEUG MODELE	YEAR JAHR ANNEE	FRONT/VORNE/AVANT				REAR/HINTEN/ARRIERE			
		PREMIUM Oil	EXCEL-G* Twin-tube Gas	GAS-A-JUST Mono-tube Gas		PREMIUM Oil	EXCEL-G* Twin-tube Gas	GAS-A-JUST Mono-tube Gas	
<b>Alfa Romeo (I)</b>									
<b>Alfa 6</b>									
2.0, 2.5, 2.5 TD	79- 87	443127	343014	553073					
					⊥ ⊕ 0,8				
<b>Alfa 33</b> ,									
1.2, 1.3, 1.3 S, 1.5 1.5 Ti, 1.5 Quadrifoglio 1.7 Quadrifoglio, 1.8 TD Incl. Giardinetta Exc. (4WD)	(905) 6.83- 7.86 6.83- 7.86 - 2.87					443221	343231		
					1,4				⊥ ⊕ 1,7
1.2, 1.3, 1.3 S, 1.5 1.5 Ti, 1.5 Quadrifoglio Incl. Giardinetta Exc. (4WD)	(905) 8.86- 2.87 8.86- 2.87						343231		
					1,4				⊥ ⊕ 1,7
1.2, 1.3, 1.3 S, 1.5 1.5 Ti, 1.5 Quadrifoglio 1.7 Quadrifoglio, 1.8 TD 1.7 ie Incl. Giardinetta Exc. (4WD)	(905) 3.87- 1.90 3.87- 1.90 3.87- 1.90 88- 1.90		333857 L 333856 R				343231		
					1,4				⊥ ⊕ 1,7
,  Exc.1.7 i.e. 16V, 1.8 TD	(907) 90- 1.93		333859 L 333858 R				343231		
					1,4				⊥ ⊕ 1,7
,  Exc.1.7 i.e. 16V, 1.8 TD	(907) 2.93-						343231		
					1,4				⊥ ⊕ 1,7
, 1.7 i.e. 16V	1.90- 3.90		333859 L 333858 R				343231		
					1,4				⊥ ⊕ 1,7
 1.7 i.e. 16V	4.90-								⊥ ⊕
									⊥ ⊕
 1.7 i.e. 16V	4.90-						343231		
									⊥ ⊕ 1,7
1.8TD	1.90-						343231		
									⊥ ⊕ 1,7
<b>Alfa 75, 90</b>									
Alfa 75 1.6,1.8, 2.0, 2.5 i, 2.0 TD, 3.0 i Alfa 90 1.8, 2.0, 2.0 i, 2.5 i, 2.4TD	5.85- 92 10.84- 89	443248	343235			443249	343236		
					⊥ ⊕ 0,8				⊥ ⊕ 0,7



MODEL FAHRZEUG MODELE	YEAR JAHR ANNEE	FRONT/VORNE/AVANT				REAR/HINTEN/ARRIERE			
		PREMIUM Oil	EXCEL-G* Twin-tube Gas	GAS-A-JUST Mono-tube Gas		PREMIUM Oil	EXCEL-G* Twin-tube Gas	GAS-A-JUST Mono-tube Gas	
<b>Alfa Romeo (I)</b>									
<b>Alfa 145/146</b>									
1.4 (1351 cc), 1.6 (1596 cc) 1.7-16V (1712 cc)	94- 97 94- 97		334916 L <sup>1)</sup> 334915 R <sup>1)</sup>					554077	
				SM2003 L	1,3				
				SM2004 R					
1.4 (1370 cc), 1.6 (1598 cc) 1.8 (1747 cc) 2.0 ti, 2.0 Quadrifoglio	97- 97- 94-		334930 <sup>2)</sup>					554077	
				SM2003 L	1,3				
				SM2004 R					
1.9 TD	94-		334917 <sup>2)</sup>					554077	
				SM2003 L	1,3				
				SM2004 R					
1)									
2)									
<b>Alfa 147</b>									
1.6, 2.0, 1.9 JTD	00-		331900				334613		
<b>Alfa 155</b>									
Twin Spark 1.6,1.7,1.8,2.0 1.9 Turbo Diesel Exc.	92- 97		334917				344115	554077	
				SM2003 L	0,7				
				SM2004 R					
2.5 Turbo Diesel Exc.	93- 97		334918				344115	554077	
				SM2003 L	0,7				
				SM2004 R					
2.5-V6 Exc.	92- 97		334919				344115	554077	
				SM2003 L	0,7				
				SM2004 R					
2.0 Turbo 16V Q4 (4WD) Exc.	92- 96		334918					554077	
				SM2003 L	0,7				
				SM2004 R					
<b>Alfa 156 </b>									
Twin Spark 1.6, 1.8, 2.0 2.5-V6 24V 1.9 JTD, 2.4JTD Exc. Sport sus.	997-		331900				334932		
Sport sus. Twin Spark 1.6, 1.8, 2.0 2.5-V6 24V 1.9 JTD, 2.4JTD	997-								

\*Excel-G is a new name of SUPER  
Excel-G ist der neue Name für SUPER  
Excel-G est le nom nouveau pour SUPER

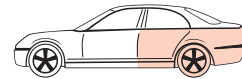
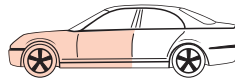

MODEL FAHRZEUG MODELE	YEAR JAHR ANNEE	FRONT/VORNE/AVANT				REAR/HINTEN/ARRIERE			
		PREMIUM Oil	EXCEL-G* Twin-tube Gas	GAS-A-JUST Mono-tube Gas		PREMIUM Oil	EXCEL-G* Twin-tube Gas	GAS-A-JUST Mono-tube Gas	
<b>Alfa Romeo (I)</b>									
<b>Alfa 156 </b>									
Sport Wagon Twin Spark 1.6, 1.8, 2.0 2.5-V6 24V 1.9JTD, 2.4JTD	5.00-		331900				334613		
<b>Alfa 164</b>									
2.0 Twin Spark/Turbo 2.5 Turbo Diesel 3.0-V6 (  → 6183988) Exc.  , Quadrifoglio	87-10.90 87-10.90 87-10.90		334920				334801		
				SM2001	1,4				1,8
2.0 Twin Spark/Turbo 2.0-V6 Turbo 2.5 Turbo Diesel 3.0-V6 (  6183989→) Exc.  , Quadrifoglio, Q4 (  )	11.90- 9.98 91- 9.98 11.90- 9.98 11.90- 9.98		334800				334801		
				SM2002	1,4				1,8
<b>Alfa 166</b>									
2.0 T.Spark, 2.0 V6 2.5 V6-24V, 3.0 V6-26 2.4 JTD	9.98-		341910				341911		
<b>Alfa Sud</b>									
1.2, 1.3, 1.5 L & Ti Giardinetta 1.5 Sprint Veloce	(901) 72- 85 75- 82 77- 3.82						441044		551019
									0,6
Sprint Ti Quadrifoglio (Alfa 33-sus.)	(901) 84- 90						443221	343231	
				SM2000					
									0,6
<b>Alfetta</b>									
1.6 1.6 GT 1.8 1.8 GT 2.0 2.0 GTV, 2.5 GTV, 2.0 Turbo Delta Turbo Diesel 2.5-V6 GTV	75- 84 76- 85 72- 84 74- 85 77- 84 76- 85 79- 86 80-11.84	443127	343014	553073		443128	343015	554031	
					0,8				0,8
2.0 GTV 2.5 GTV	85- 90 85- 90	443248	343235			443249	343236		
					0,8				0,8
<b>Arna</b>									
1.2 SL, 1.3, 1.5 Ti	11.84- 86						342008		
				SM2000					
									0,8
<b>Giulia</b>									
1300 1600 1750 Berlina, GTV, Spider Montreal 2000 Berlina, GTV, Spider Diesel	67- 80 67- 74 68- 72 70- 76 71- 76 76- 78	443114	343051	553072		443126		551027	
					0,9				1,1



MODEL FAHRZEUG MODELE	YEAR JAHR ANNEE	FRONT/VORNE/AVANT				REAR/HINTEN/ARRIERE			
		PREMIUM Oil	EXCEL-G* Twin-tube Gas	GAS-A-JUST Mono-tube Gas		PREMIUM Oil	EXCEL-G* Twin-tube Gas	GAS-A-JUST Mono-tube Gas	
<b>Alfa Romeo (I)</b>									
<b>Giulietta</b>									
1.3, 1.6 1.8 2.0	77- 86 79- 86 80- 86	443127	343014	553073		443128	343015	554031	
<b>GTV (916)</b>									
1.8-16V Twin Spark 2.0-16V Twin Spark	11.94-		334913					553205	
2.0 V6 Turbo	11.94-		334914▼					553205	
3.0 V6 Turbo	11.96-							553205	
<b>Spider (916)</b>									
1.8-16V Twin Spark 2.0-16V Twin Spark	11.94-		334913					553205	
3.0 V6	11.94-		334914▼					553205	
<b>Audi (D)</b>									
<b>50</b>									
	9.74- 78	663035 <sup>1)</sup>	363043 <sup>1)</sup> 373025 <sup>1)</sup>			441019 <sup>2)</sup> 443165 <sup>3)</sup>	341023 <sup>2)</sup> 343165 <sup>3)</sup> 351004 <sup>2)</sup>	551015 <sup>2)</sup>	
			915410	SM1703			915412		
1)       2)        3)									
<b>80 (72-78)</b>									
	72- 8.78	664001	364001			441001	341033	551002	
Variant	75- 8.78	664001	364001			443049	343089	554018	

\*Excel-G is a new name of SUPER  
 Excel-G ist der neue Name für SUPER  
 Excel-G est le nom nouveau pour SUPER

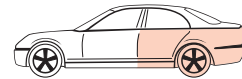
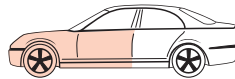

MODEL FAHRZEUG MODELE	YEAR JAHR ANNEE	FRONT/VORNE/AVANT				REAR/HINTEN/ARRIERE			
		PREMIUM Oil	EXCEL-G* Twin-tube Gas	GAS-A-JUST Mono-tube Gas		PREMIUM Oil	EXCEL-G* Twin-tube Gas	GAS-A-JUST Mono-tube Gas	
<b>Audi (D)</b>									
<b>80/90  , 80 Variant/Avant  (78-91)</b>									
80  (Exc. Quattro) 90  (Exc. Quattro)	9.78- 86 10.84- 86	665030 <sup>1)</sup>	365008 <sup>1)</sup> <u>375008</u> <sup>1)</sup>			441022	341003 <u>351005</u>	551020	
					2,9				⊥ ⊕ 0,9
80 Quattro (81) 90 Quattro (81) Exc.Sport sus.	9.83- 8.86 9.84-12.86	665030 <sup>1)</sup>	365008 <sup>1)</sup> <u>375008</u> <sup>1)</sup>			666002	366006 <u>376002</u>		
					2,9				⊥ 3,6
80 90 Exc. Quattro, Sport sus., 2.3, 2.3-20V	10.86- 8.91 87- 8.91	665030 <sup>1)</sup>	365008 <sup>1)</sup> <u>375008</u> <sup>1)</sup>			441022	341003 <u>351005</u>	551020	
					2,9				⊥ ⊕ 0,9
80 Quattro (89) 90 Quattro (89) Exc. Sport sus., 2.3, 2.3-20V	9.86- 8.91 1.87- 8.91	665030 <sup>1)</sup>	365008 <sup>1)</sup> <u>375008</u> <sup>1)</sup>			666002	366006 <u>376002</u>		
					2,9				⊥ 3,6
<b>80  , Variant/Avant  (91-95)</b>									
80 (B4) 1.6, 2.0, 2.0E, 2.3E, 1.9TD, 1.9 TDI Exc.Sport sus., Quattro,	9.91- 95	665030 <sup>1)</sup>	365008 <sup>1)</sup> <u>375008</u> <sup>1)</sup>			441901 ▼ 441083	341901 ▼ 341130 <u>351006</u>	551055	
					2,9				⊥ ⊕ 0,9
80 (B4) 2.6E, 2.8E Exc. Sport sus., Quattro	9.91- 95		365008 <sup>1)</sup> <u>375008</u> <sup>1)</sup>				341901 ▼ 341130 <u>351006</u>	551055	
					2,9				⊥ ⊕ 0,9
80 (B4) ⊕ Sport sus.  Exc. Quattro	9.91- 95		365008 <sup>1)</sup> <u>375008</u> <sup>1)</sup>				341132 <u>351006</u>	551056	
					2,9				⊥ ⊕ 0,9
80 (B4) ⊕  Exc. Quattro	9.91- 95								⊥ ⊕
80 (B4) Quattro 2.0 E, 2.3 E, 2.6 E, 2.8 E 2.3 E, 2.6 E, 2.8 E Incl. Sport sus.	92- 95		365008 <sup>1)</sup> <u>375008</u> <sup>1)</sup>						⊥ ⊕
					2,9				
1)									



MODEL FAHRZEUG MODELE	YEAR JAHR ANNEE	FRONT/VORNE/AVANT				REAR/HINTEN/ARRIERE			
		PREMIUM Oil	EXCEL-G* Twin-tube Gas	GAS-A-JUST Mono-tube Gas		PREMIUM Oil	EXCEL-G* Twin-tube Gas	GAS-A-JUST Mono-tube Gas	
<b>Audi (D)</b>									
<b>100  , 100 Avant </b>									
	68- 73		345001		$\perp$ $\ominus$		343069	554001	$\perp$ $\ominus$
	8.73- 3.74		345001		$\perp$ $\ominus$		341014		$\perp$ $\ominus$
 5100108 →	4.74- 76	445004	345002		$\perp$ $\ominus$	441002	341014		$\perp$ $\ominus$
	76- 8.82	666001	366002		$\perp$ 3,2	443111	343013	554025	$\perp$ $\ominus$ 0,7
 Exc. Quattro	9.82- 90	666001	366002 <u>376001</u>		$\perp$ 3,2	441040	341016 <u>351017</u>		$\perp$ $\ominus$ 0,7
 Exc. Sport sus., Quattro, S 4,	(C 4) 12.90- 94	666001	366002 <u>376001</u>		$\perp$ 3,2	441902 <sup>1)4)</sup> 441084 <sup>5)</sup>	341902 <sup>1)4)</sup> 341133 <sup>5)</sup> <u>351018</u> <sup>1)</sup>		$\perp$ $\ominus$ 0,7
Sport sus. Exc. Quattro, S4	(C 4) 12.90- 94		366002 <u>376001</u>		$\perp$ 3,2		341902 <sup>1)4)</sup> 341133 <sup>5)</sup> <u>351018</u> <sup>1)</sup>		$\perp$ $\ominus$ 0,7
Quattro Exc. Sport sus., S4,	(C 4) 10.84- 94	666001	366002 <sup>2)</sup> <sup>3)</sup>		$\perp$ 3,2		341205 <sup>1)</sup>		$\perp$ $\ominus$ 1,7
Quattro  Sport sus. Exc. S4	(C 4) 10.84- 94		366002 <sup>2)</sup> <sup>3)</sup>		$\perp$ 3,2		341206 <sup>1)</sup>		$\perp$ $\ominus$ 1,7
S4. Incl.  Sport sus.	(C 4) 92- 94		<u>376001</u>		$\perp$ 3,2		<u>351020</u> <sup>1)</sup>		$\perp$ $\ominus$ 1,7
1) Exc.       2) 10.84 - 12.90      3) 91 - 94      4)        5)									
<b>200  , 200 Avant </b>									
	80- 8.83	666001	366002		$\perp$ 3,2	443111	343013 Exc.	554025	$\perp$ $\ominus$ 0,7

\* Excel-G is a new name of SUPER  
 Excel-G ist der neue Name für SUPER  
 Excel-G est le nom nouveau pour SUPER



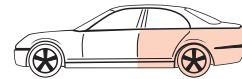
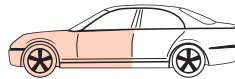

MODEL FAHRZEUG MODELE	YEAR JAHR ANNEE	FRONT/VORNE/AVANT			⚙️ ⌚	REAR/HINTEN/ARRIERE			⚙️ ⌚
		PREMIUM Oil	EXCEL-G* Twin-tube Gas	GAS-A-JUST Mono-tube Gas		PREMIUM Oil	EXCEL-G* Twin-tube Gas	GAS-A-JUST Mono-tube Gas	
<b>Audi (D)</b>									
<b>200 🚗 , 200 Avant 🚗</b>									
 Exc. Quattro	9.83- 90	666001	366002 <u>376001</u>		⏏ 3,2	441040	341016 <u>351017</u>		⊥ ⊖ 0,7
							Exc.		
Quattro Exc. Sport sus., 2.3-20V Turbo	86- 90	666001	366002 		⏏ 3,2		341205 Exc.		⊥ ⊖ 1,7
Quattro 2.3-20V Turbo Incl.  Sport sus.	86- 90		366002 		⏏ 3,2		341206 Exc.		⊥ ⊖ 1,7
Quattro  Sport sus. 	86- 90		366002 		⏏ 3,2		341206 Exc.		⊥ ⊖ 1,7
<b>A2</b>									
	00-						343328		⊥ ⊖
<b>A3 🚗 (8L1)</b>									
 1.6, 1.8, 1.8 Turbo, 1.9TDI Exc. Sport sus.,	96- 7.99	634099▼ 634812	334220▼ 334812 <u>324016</u>				343280▼ 343348	553206 <u>243037</u>	⊥ ⊖
 1.6, 1.8, 1.8 Turbo, 1.9TDI Exc. Sport sus.,	8.99-	634099▼ 634812	334220▼ 334812 <u>324016</u>				343280▼ 343348	553206 <u>243037</u>	⊥ ⊖
 Sport sus.	96- 7.99		334220▼ 334812 <u>324016</u>					553206 <u>243037</u>	⊥ ⊖
 Sport sus.	8.99-		334220▼ 334812 <u>324016</u>					553206 <u>243037</u>	⊥ ⊖
Quattro  Exc. Sport sus., S3	96- 7.99	634099▼ 634812	334220▼ 334812 <u>324016</u>				343310	553243 <u>243038</u>	⊖ ⊖





MODEL FAHRZEUG MODELE	YEAR JAHR ANNEE	FRONT/VORNE/AVANT			⚙️ ⌚	REAR/HINTEN/ARRIERE			⚙️ ⌚
		PREMIUM Oil	EXCEL-G* Twin-tube Gas	GAS-A-JUST Mono-tube Gas		PREMIUM Oil	EXCEL-G* Twin-tube Gas	GAS-A-JUST Mono-tube Gas	
<b>Audi (D)</b>									
<b>A3 🚗 (8L1)</b>									
Quattro ⚙️ ALL Exc. Sport sus., S3	8.99-				⊕			553243 <u>243038</u>	⊕ ⊕
			915415	SM1708					
Quattro ⊕ Sport sus. ⚙️ ALL Exc. S3	96- 7.99		334220 ▼ 334812 <u>324016</u>	SM1708	⊕			553243 <u>243038</u>	⊕ ⊕
			915415	SM1708					
Quattro ⊕ Sport sus. ⚙️ ALL Exc. S3	8.99-				⊕			553243 <u>243038</u>	⊕ ⊕
			915415	SM1708					
Quattro ⊕ 🚗 ⚙️ ALL Exc. S3	96- 7.99		334220 ▼ 334812 <u>915415</u>	SM1708	⊕		344301		⊕ ⊕
			915415	SM1708					
Quattro ⊕ 🚗 ⚙️ ALL Exc. S3	8.99-				⊕		344301		⊕ ⊕
			915415	SM1708					
<b>A4 🚗 , A4 Avant 🚗</b>									
⚙️ ALL Exc. Sport sus., Quattro (B5)	94- 1.99		341904 <sup>1)</sup> <u>351016<sup>2)</sup></u> 915708		⊥ ⊗ 1,6		343271 <sup>2)</sup> <u>353014<sup>2)</sup></u> 915416		⊥ ⊕ 1,6
⊕ Sport sus. ⚙️ ALL Exc. Quattro (B5)	94- 1.99		<u>351016<sup>2)</sup></u> 915708		⊥ ⊗ 1,6		343271 <sup>2)</sup> <u>353014<sup>2)</sup></u> 915416		⊥ ⊕ 1,6
Quattro (B5) 1.8, 1.8 Turbo, 2.6, 2.8, 1.9TDi, 2.5TDi Exc. Sport sus., S4	94- 1.99		341904 <sup>1)</sup> <u>351016<sup>2)</sup></u> 915708		⊥ ⊗ 1,6		341909		⊕ ⊕
Quattro ⊕ Sport sus. (B5) 1.8, 1.8 Turbo, 2.6, 2.8, 1.9TDi, 2.5TDi Exc. S4	94- 1.99		<u>351016<sup>2)</sup></u> 915708		⊥ ⊗ 1,6		341909		⊕ ⊕
🚗 ⚙️ ALL Exc. Sport sus., Quattro, 🚗 (B5)	2.99-11.00		341904 <sup>1)</sup> <u>351016<sup>2)</sup></u> 915708		⊥ ⊗ 1,6		343302 <sup>2)</sup> <u>353016<sup>2)</sup></u>		⊥ ⊕
1)  KYB									
2)  OE									

\*Excel-G is a new name of SUPER  
Excel-G ist der neue Name für SUPER  
Excel-G est le nom nouveau pour SUPER

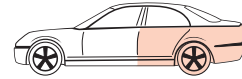
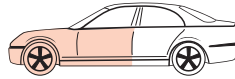

Audi

MODEL FAHRZEUG MODELE	YEAR JAHR ANNEE	FRONT/VORNE/AVANT				REAR/HINTEN/ARRIERE			
		PREMIUM Oil	EXCEL-G* Twin-tube Gas	GAS-A-JUST Mono-tube Gas		PREMIUM Oil	EXCEL-G* Twin-tube Gas	GAS-A-JUST Mono-tube Gas	
<b>Audi (D)</b>									
<b>A4  , A4 Avant </b>									
⊕ Sport sus. Exc. Quattro	(B5)	2.99-11.00		351016 <sup>2)</sup> 	 1,6		343302 <sup>2)</sup> 353016 <sup>2)</sup>		
Quattro Exc. Sport sus., S4	(B5)	2.99-11.00		341904 <sup>1)</sup> 351016 <sup>2)</sup> 	 1,6		341909		
Quattro ⊕ Sport sus.  Exc. S4	(B5)	2.99-11.00		351016 <sup>2)</sup> 	 1,6		341909		
 Exc. Sport sus., Quattro,	(B5)	2.99- 9.01		341904 <sup>1)</sup> 351016 <sup>2)</sup> 	 1,6		343302 <sup>2)</sup> 353016 <sup>2)</sup>		
⊕ Sport sus. Exc. Quattro	(B5)	2.99- 9.01		351016 <sup>2)</sup> 	 1,6		343302 <sup>2)</sup> 353016 <sup>2)</sup>		
Quattro Exc. Sport sus., S4	(B5)	2.99- 9.01		341904 <sup>1)</sup> 351016 <sup>2)</sup> 	 1,6		341909		
Quattro ⊕ Sport sus.  Exc. S4	(B5)	2.99- 9.01		351016 <sup>2)</sup> 	 1,6		341909		
 1.6, 1.8 Turbo, 2.0, 3.0 1.9 TDI, 2.5 TDi Exc. Sport,  , Quattro	(8E, B6)	11.00-		341299 <sup>2)</sup>	 1,6		341814		
⊕ Sport sus. 1.6, 1.8 Turbo, 2.0, 3.0 1.9 TDI, 2.5 TDi Exc. Quattro	(8E, B6)	11.00-		341299 <sup>2)</sup>	 1,6		341814		
Quattro 1.8 Turbo, 3.0, 2.5 TDi Exc. Sport,	(8E, B6)	11.00-		341299 <sup>2)</sup>	 1,6		341814		
Quattro ⊕ Sport sus. 1.8 Turbo, 3.0, 2.5 TDi	(8E, B6)	11.00-		341299 <sup>2)</sup>	 1,6		341814		
1)		2)							



MODEL FAHRZEUG MODELE	YEAR JAHR ANNEE	FRONT/VORNE/AVANT				REAR/HINTEN/ARRIERE			
		PREMIUM Oil	EXCEL-G* Twin-tube Gas	GAS-A-JUST Mono-tube Gas		PREMIUM Oil	EXCEL-G* Twin-tube Gas	GAS-A-JUST Mono-tube Gas	
<b>Audi (D)</b>									
<b>A6  , A6 Avant </b>									
(C4) Exc. Sport sus., Quattro,	94- 97	666001	366002 <u>376001</u> 		 3,2	441902 <sup>1)3)</sup> 441084 <sup>2)</sup>	341902 <sup>1)3)</sup> 341133 <sup>2)</sup> <u>351018<sup>1)</sup></u> <sup>1)</sup>		 ⊥ ⊕ 1,1
Sport sus.  (C4) Exc. S6	94- 97		366002 <u>376001</u> 		 3,2		341902 <sup>1)3)</sup> 341133 <sup>2)</sup> <u>351018<sup>1)</sup></u>		 ⊥ ⊕ 1,1
Quattro C (C4) Exc. Sport sus., S6,	94- 97	666001	366002 		 3,2		341205 <sup>1)</sup>		 ⊥ ⊕ 1,7
Quattro  Sport sus.  (C4) Exc. S6	94- 97		366002 		 3,2		341206 <sup>1)</sup>		 ⊥ ⊕ 1,7
S6  (C4) Incl.  Sport sus.	94- 97		<u>376001</u>		 3,2		<u>351020<sup>1)</sup></u>		 ⊥ ⊕ 1,7
(4B) Exc. Sport sus., Quattro, S6,	97- 5.01		341207 <sup>3)</sup> 341904 <sup>2)</sup>		 ⊥ ⊗		343281 <sup>1)</sup> 553207 <sup>1)</sup>		 ⊥ ⊕
Sport sus.  (4B) Exc. Quattro, S6,	97- 5.01		341207 <sup>3)</sup>		 ⊥ ⊗		553207 <sup>1)</sup>		 ⊥ ⊕
Quattro  (4B) Exc. Sport sus., S6,	97- 5.01		341207 <sup>3)</sup> 341904 <sup>2)</sup>		 ⊥ ⊗				 ⊥ ⊕
Quattro  Sport sus.  (4B) Exc. S6,	97- 5.01		341207 <sup>3)</sup>		 ⊥ ⊗				 ⊥ ⊕
(4B) Exc. Sport sus., Quattro, S6,	6.01-		341273 <sup>3)</sup>		 ⊥ ⊗		343281 <sup>1)</sup> 553207 <sup>1)</sup>		 ⊥ ⊕
Sport sus.  (4B) Exc. Quattro, S6,	6.01-		341273 <sup>3)</sup>		 ⊥ ⊗		553207 <sup>1)</sup>		 ⊥ ⊕
(4B) Exc. Sport sus., Quattro, S6,	6.01-		341273 <sup>3)</sup>		 ⊥ ⊗				 ⊥ ⊕
1)   Exc. 2) 3)									

\*Excel-G is a new name of SUPER  
 Excel-G ist der neue Name für SUPER  
 Excel-G est le nom nouveau pour SUPER



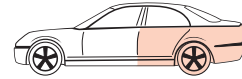
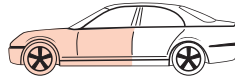

Audi

MODEL FAHRZEUG MODELE	YEAR JAHR ANNEE	FRONT/VORNE/AVANT				REAR/HINTEN/ARRIERE			
		PREMIUM Oil	EXCEL-G* Twin-tube Gas	GAS-A-JUST Mono-tube Gas		PREMIUM Oil	EXCEL-G* Twin-tube Gas	GAS-A-JUST Mono-tube Gas	
<b>Audi (D)</b>									
<b>A6  , A6 Avant </b>									
⊕ Sport sus. Exc. Quattro, S6,	(4B)	6.01-		341273 <sup>1)</sup>					
Quattro  Exc. Sport sus., S6,	(4B)	6.01-		341273 <sup>1)</sup>					
Quattro ⊕ Sport sus. Exc. Sport sus., S6,	(4B)	6.01-		341273 <sup>1)</sup>					
<b>Cabrio</b>									
		6.91- 8.00		365008 <sup>2)</sup> 375008 <sup>2)</sup> SM1702			341912		
<b>Coupé</b>									
GT5E GT		8.83- 9.88 8.81- 9.88	665030 <sup>2)</sup>	365008 <sup>2)</sup> 375008 <sup>2)</sup> SM1702			441022	341003 351005	551020 
Quattro (85)  Exc.Sport sus.		9.84- 9.88	665030 <sup>2)</sup>	365008 <sup>2)</sup> 375008 <sup>2)</sup> SM1702			666002	366006 376002	
(89) Incl. Sport sus. Exc. 2.0 ⊕		10.88-		365008 <sup>2)</sup> 375008 <sup>2)</sup> SM1702				341153 351015	
Quattro (89)  Exc. S2		10.88-		365008 <sup>2)</sup> 375008 <sup>2)</sup> SM1702				366008 376003	
S2 Quattro (89)		90-						366008 376003	
1)	2)								
<b>TT Coupé </b>									
1.8T Exc. Sport sus.		10.98-		SM1708				553206	



MODEL FAHRZEUG MODELE	YEAR JAHR ANNEE	FRONT/VORNE/AVANT				REAR/HINTEN/ARRIERE			
		PREMIUM Oil	EXCEL-G* Twin-tube Gas	GAS-A-JUST Mono-tube Gas		PREMIUM Oil	EXCEL-G* Twin-tube Gas	GAS-A-JUST Mono-tube Gas	
<b>Audi (D)</b>									
<b>TT Coupé</b>									
1.8T Quattro Exc. Sport sus.	10.98-							553243	
SM1708									
<b>TT Roadster Cabriolet</b>									
1.8T Exc. Sport sus.	10.98-						343280▼ 343348	553206	
1.8T Quattro Exc. Sport sus.	10.98-							553243	
SM1708									
<b>V8</b>									
V8-3.6 V8-4.2	88- 94 91- 94		366002				341206		
3.2									
Exc.									
<b>Austin-Rover Group (GB)</b>									
<b>Austin, Morris</b>									
 Seven 850, Cooper (S) Mini Car 850, 1000, 1275 GT Mini Clubman Mini-Minor Mini-Cooper Hornet	59- 74 76- 76- 59- 76 61- 64 62- 64	442001	342001	552018		442002	342002	552019	
0,7									
 Seven 850 Van, Countryman, Pick-up Mini Clubman Estate Mini Countryman Van, Pickup	59- 76 76- 61- 69	442001	342001	552018		442003	342006		
0,7									
Mini Metro  Incl.	80-	442031	342016						
1,3									
Mini (Denovo tires)	5.76-	442001	342001	552018		442016	342009		
0,7									
<b>Maestro Sedan, Hatchback</b>									
1.3, 1.6 2.0 MG E.F.I.	83- 84-	633101 S.S.H. =	333075 264 mm			441070 S.S.H. =	341103 181 mm		
1,5									
1.3 Exc.	84-	633101 S.S.H. =	333075 264 mm			441073 S.S.H. =	341106 157 mm		
1,5									
S.S.H. =  S.S.H. =									

\*Excel-G is a new name of SUPER  
 Excel-G ist der neue Name für SUPER  
 Excel-G est le nom nouveau pour SUPER



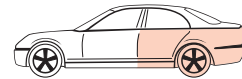
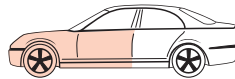

MODEL FAHRZEUG MODELE	YEAR JAHR ANNEE	FRONT/VORNE/AVANT				REAR/HINTEN/ARRIERE			
		PREMIUM Oil	EXCEL-G* Twin-tube Gas	GAS-A-JUST Mono-tube Gas		PREMIUM Oil	EXCEL-G* Twin-tube Gas	GAS-A-JUST Mono-tube Gas	
<b>Austin-Rover Group (GB)</b>									
<b>Maestro Sedan, Hatchback</b>									
1.6  Exc.	84-	633193 S.S.H. =	333223 250 mm		 1,5	441073 S.S.H. =	341106 157 mm		 1,7
2.0 Diesel Hatchback	86-	633193 S.S.H. =	333223 250 mm			441070 S.S.H. =	341103 181 mm		 1,7
<b>Maestro Van</b>									
	84- 90	633101	333075		 1,5	443275			 0,8
	90- 94	633101	333075		 1,5	443276			 0,8
<b>Montego Saloon</b>									
1.3  Exc. 1.6, 2.0 (U.K.) Exc. 2.0 MG E.F.I. (U.K.) Incl. Exc. 2.0 MG Turbo	84-	633101 S.S.H. =	333075 264 mm		 1,5	if S.S.H. = 181 mm 441070 341103 if S.S.H. = 157 mm 441073 341106			 1,7
1.3 1.6, 2.0   (U.K.) 1.6, 2.0  (Exc. U.K.) 1.6, 2.0 Police (U.K.) 2.0 MG E.F.I. (Exc. U.K.) 2.0 Diesel LD, HLD Exc. 2.0 MG Turbo	84- 84- 84- 84- 84- 86-	633193 S.S.H. =	333223 250 mm		 1,5	if S.S.H. = 181 mm 441070 341103 if S.S.H. = 157 mm 441073 341106			 1,7
2.0 MG Turbo Exc.	85- 2.87					441072 S.S.H. =	341105 167 mm		 1,7
2.0 MG Turbo	3.87-								
2.0 HL, VP, Auto (Gulf States only)	85- 2.87								
<b>Montego Estate</b> Exc.									
1.6, 2.0  Exc. 2.0 Diesel	84- 9.88	633101 S.S.H. =	333075 264 mm		 1,5	441073 S.S.H. =	341106 157 mm		 1,7
2.0 Diesel LD, HLD 	86- 9.88	633193 S.S.H. =	333223 250 mm		 1,5	441073 S.S.H. =	341106 157 mm		 1,7



MODEL FAHRZEUG MODELE	YEAR JAHR ANNEE	FRONT/VORNE/AVANT				REAR/HINTEN/ARRIERE			
		PREMIUM Oil	EXCEL-G* Twin-tube Gas	GAS-A-JUST Mono-tube Gas		PREMIUM Oil	EXCEL-G* Twin-tube Gas	GAS-A-JUST Mono-tube Gas	
<b>Austin-Rover Group (GB)</b>									
<b>Montego Estate  Exc. </b>									
1.6, 2.0, 2.0 Diesel LD, HLD 	10.88-	633193 S.S.H. =	333223 250 mm			441072 S.S.H. =	341105 167 mm		
					1,5				
<b>Sherpa</b>									
185 (13 cwt) 215, 220, 230 (18 cwt) 240, 250 (22 cwt)	9.74- 7.82					444048			
K2 Series 180, 215, 220, 240, 250 Incl. H/D	7.82-	443282				444133			
K2 Series 255	7.82-	443288				444133			
200 Series 200, 230, 250, 280	83-	445027				444143			
200 Series 255, 280	83-	443288							
300 Series 285, 310, 350 = 2.9m, 3.2m, 3.6m Incl. 2 ton Axle leaf spring	83- 4.89	444142				444143			
400 Series 400-2.8 ton, 3.1 ton, 3.5 ton = 2.9m, 3.2m, 3.6m	4.89-	444142				444143			
<b>Triumph</b>									
Spitfire Mk IV	70- 8.80	441032	341028					552016	
Vitesse Mk II GT 6 Mk II	68- 71	441032	341028						
2000 Mk I, II Incl. 2.5 P1 2500 TC, S Stag	63- 75 68- 75 74- 77 70- 77		365048					554017	
TR 7 TR 8	5.76- 80 80- 83	663006	363015					554017	

\*Excel-G is a new name of SUPER  
 Excel-G ist der neue Name für SUPER  
 Excel-G est le nom nouveau pour SUPER

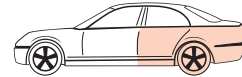
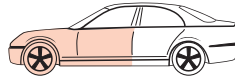

MODEL FAHRZEUG MODELE	YEAR JAHR ANNEE	FRONT/VORNE/AVANT				REAR/HINTEN/ARRIERE			
		PREMIUM Oil	EXCEL-G* Twin-tube Gas	GAS-A-JUST Mono-tube Gas		PREMIUM Oil	EXCEL-G* Twin-tube Gas	GAS-A-JUST Mono-tube Gas	
<b>Austin-Rover Group (GB)</b>									
<b>Triumph</b>									
Dolomite 1300, 1500, 1850 Dolomite Sprint	1.72-11.80 6.73-11.80	441014	341020		$\perp$ $\ominus$	441015	341021		$\perp$ $\ominus$
Acclaim	10.81- 7.84	633034	333021		$\oplus$ 1,8	633036 L 633035 R	333023 L 333022 R		$\oplus$ 2,0
<b>Rover 100 ~ 800 series, P6, SD1, Landrover ⇒ Rover (GB)</b>									
<b>Auto Bianchi (I)</b>									
<b>A 112</b>									
47201 →	69-	633014	333004		$\oplus$ 1,1	633003	333005		$\oplus$ 1,3
<b>Bianchina</b>									
Bianchina Bianchina Giardiniera	57- 67 68- 74	443005	343070		$\perp$	443006	343071		$\perp$
<b>Y 10</b>									
1000, 1050, 1300, Turbo	3.85- 93	633851 L 633850 R	333867 L 333866 R		$\oplus$ 1,1	441077	341209		$\circ$ $\otimes$ 0,4
1000, 1100	3.85- 93	633851 L 633850 R	333867 L 333866 R		$\oplus$ 1,1	441094	341210		$\circ$ $\otimes$ 0,5
1000, 1050, 1300, Turbo	93- 96	633851 L 633850 R	333867 L 333866 R		$\oplus$ 1,1		341187		$\circ$ $\otimes$ 0,4
1000, 1100	93- 96	633851 L 633850 R	333867 L 333866 R		$\oplus$ 1,1		341188		$\circ$ $\otimes$ 0,5
<b>Bedford (GB)</b>									
<b>Astra, Chevanne, Rascal Van</b>									
Astra (9 TC, TD 70)	82- 91	665036	365025		$\perp$ 2,4	443135	343099	553137	$\ominus$ T 0,8
Astra	91- 97	665066	365078		$\perp$ 2,4	443135	343099	553137	$\ominus$ T 0,8





MODEL FAHRZEUG MODELE	YEAR JAHR ANNEE	FRONT/VORNE/AVANT				REAR/HINTEN/ARRIERE			
		PREMIUM Oil	EXCEL-G* Twin-tube Gas	GAS-A-JUST Mono-tube Gas		PREMIUM Oil	EXCEL-G* Twin-tube Gas	GAS-A-JUST Mono-tube Gas	
<b>Bedford (GB)</b>									
<b>Astra, Chevanne, Rascal Van</b>									
Astra max  (9 TC, TD 25) 	9.85- 93	665036	365025			443233	343227		
Chevanne 9 cwt	76- 82	443026	343048	553009		443025	343081	553010	
Rascal Van	86-	633061 L 633060 R				442028			
<b>CF series</b>									
CF 14, 18, 22, 25, 35 cwt	10.69- 76	444045 H/D 445010				444046 H/D 445011			
CF 220, 250, 280	1.76- 82	445010				445011			
CF 230, 250, 280	83-	445010 OE = 91095938							
CF 340	1.76-	445010				445011			
CF 350 	1.76-	445010				445011			
CF2 35 cwt (035)	83- 2.84	445010				445011			
CF 18, 22, 25 cwt	2.84-	445010 OE = 91095938				445011			
CF Electric		445010							
CF 97370, CF 97170		445010 OE = 91095938							
CF 97 K 60, CF 97760		445010 OE = 91095938				445011			
<b>Fargo/Midi/Seta </b>									
(WFR series) =	85- 88	444065	344113			444040	344114		

\*Excel-G is a new name of SUPER  
 Excel-G ist der neue Name für SUPER  
 Excel-G est le nom nouveau pour SUPER

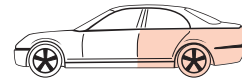
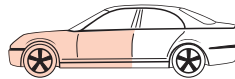

MODEL FAHRZEUG MODELE	YEAR JAHR ANNEE	FRONT/VORNE/AVANT				REAR/HINTEN/ARRIERE			
		PREMIUM Oil	EXCEL-G* Twin-tube Gas	GAS-A-JUST Mono-tube Gas		PREMIUM Oil	EXCEL-G* Twin-tube Gas	GAS-A-JUST Mono-tube Gas	
<b>Bedford (GB)</b>									
<b>Fargo/Midi/Seta</b>									
(9800 series)	88-	444065	344113		$\frac{\perp}{\oplus}$ 0,5	444040	344114		$\frac{\circ}{\oplus}$ 0,4
(9400 series)	88-				$\frac{\perp}{\oplus}$	444025		554075	$\frac{\circ}{\oplus}$ 0,4
<b>KB series</b>									
KB 25/26 (95 G 25, 95 G, D 26)	80-	443190		553119	$\frac{\perp}{\oplus}$ 1,0	443186		553108	$\frac{\circ}{\oplus}$ 1,0
KB 41 (95 G, D 41)	82-	443188		553087	$\frac{\perp}{\oplus}$ 1,0	443186		553108	$\frac{\circ}{\oplus}$ 1,0
<b>BMW (D)</b>									
<b>3 Series (E21)</b>									
316, 318, 318 A, 320, 320 A, 320i, 320 (6 cyl.) 315, 318i	10.76-10.82 80- 82	663002	363016 <u>373011</u>		$\frac{\perp}{\oplus}$ 2,6	441003	341015	551001 <u>241003</u>	$\frac{\perp}{\oplus}$ 1,0
			SM1002						
323i	78-10.82	665048	365042 <u>375020</u>		$\frac{\perp}{\oplus}$ 2,6	441003	341015	551001 <u>241003</u>	$\frac{\perp}{\oplus}$ 1,0
			SM1002						
<b>3 Series (E30)  ,  Exc. M-Technique sus.</b>									
316, 316i, 318i, 318iS, 324d Exc. Sport	82-12.90	663049 <sup>1)</sup>	363044 <sup>1)</sup> <u>373019<sup>1)</sup></u>		$\frac{\perp}{\oplus}$ 2,0	443207	343184	553124 <u>243019</u>	$\frac{\perp}{\oplus}$ 0,6
			SM1000  						
320i Exc. Sport	82- 9.87	663049 <sup>1)</sup>	363044 <sup>1)</sup> <u>373019<sup>1)</sup></u>		$\frac{\perp}{\oplus}$ 2,0	443207	343184	553124 <u>243019</u>	$\frac{\perp}{\oplus}$ 0,6
			SM1000  						
320i Exc. Sport	10.87-12.90		363044 <sup>1)</sup> <u>373019<sup>1)</sup></u>		$\frac{\perp}{\oplus}$ 2,0		343184	553124 <u>243019</u>	$\frac{\perp}{\oplus}$ 0,6
			SM1000  						
1)									



MODEL FAHRZEUG MODELE	YEAR JAHR ANNEE	FRONT/VORNE/AVANT				REAR/HINTEN/ARRIERE			
		PREMIUM Oil	EXCEL-G* Twin-tube Gas	GAS-A-JUST Mono-tube Gas		PREMIUM Oil	EXCEL-G* Twin-tube Gas	GAS-A-JUST Mono-tube Gas	
<b>BMW (D)</b>									
<b>3 Series (E30)  ,  Exc. M-Technique sus.</b>									
316/316i Sport 318i/318iS Sport 320i Sport 324d Sport	82-12.90		364021 <sup>2)</sup> 374008 <sup>1)2)</sup>  				343184	553124 243019	
320iS, 323i, 324td, 325e, 325i Incl. Sport Exc. (4WD) (325iX)	82-12.90		364021 <sup>2)</sup> 374008 <sup>2)</sup>  				343184	553124 243019	
<b>3 Series (E 30)  Exc. M- Technique sus.</b>									
318i, 320i, 325i Incl. Sport Exc. (4WD) (325iX)	85- 2.93		364021 <sup>2)</sup> 374008 <sup>2)</sup>  				343184	553124 243019	
<b>3 Series (E 30)  Exc. M- Technique sus.</b>									
316i, 318i Exc. Sport	3.89- 9.89		363044 <sup>1)</sup> 373019 <sup>1)</sup>  				343184	553124 243019	
316i, 318i Exc. Sport	10.89- 2.94		364021 <sup>2)</sup> 374008 <sup>2)</sup>  				343184	553124 243019	
316i Sport 318i Sport	3.89- 2.94		364021 <sup>2)</sup> 374008 <sup>2)</sup>  				343184	553124 243019	
320i, 324td, 325i Incl. Sport Exc. (4WD) (325iX)	88- 2.94		364021 <sup>2)</sup> 374008 <sup>2)</sup>  				343184	553124 243019	
<p>1) </p> <p>2) </p>									

\*Excel-G is a new name of SUPER  
Excel-G ist der neue Name für SUPER  
Excel-G est le nom nouveau pour SUPER



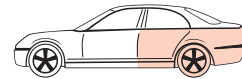
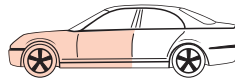

MODEL FAHRZEUG MODELE	YEAR JAHR ANNEE	FRONT/VORNE/AVANT				REAR/HINTEN/ARRIERE			
		PREMIUM Oil	EXCEL-G* Twin-tube Gas	GAS-A-JUST Mono-tube Gas		PREMIUM Oil	EXCEL-G* Twin-tube Gas	GAS-A-JUST Mono-tube Gas	
<b>BMW (D)</b>									
<b>3 Series (E 30) ⊕ M- Technique sus. Exc. (4WD) (325iX), M3</b>									
	82-12.90 85- 2.93 89- 2.94		374008 <sup>1)</sup>	371004 <sup>2)</sup>				243019	$\perp$ 0,6
				SM1000	2,0				
1) 2)									
<b>3 Series (E 30) M3</b>									
	87- 91				SM1000				
<b>3 Series Compact (E36)  Exc. M-Technique sus.</b>									
316i, 318ti, 318tds Exc. 323ti,	4.94- 01		333910 L 333909 R		SM1001	$\oplus$	343268	553192	$\perp$ 0,8
					SM1001	2,1			
	4.94- 01	OE = 31311 091 624 /623 (R/L)			SM1001	$\oplus$	343268	553192	$\perp$ 0,8
					SM1001	2,1			
<b>3 Series Compact (E36)  ⊕ M-Technique sus.</b>									
316i, 318ti, 318tds	4.94- 01		333933 L 333932 R		SM1001	$\oplus$		553192 Incl.	$\perp$ 0,8
<b>3 Series (E36) ,  Exc. M-Technique sus., M3</b>									
316i, 318i	90- 8.91		333916 L 333915 R		SM1001	$\oplus$	343255	553180	$\perp$ 0,8
			 		SM1001	2,1			
316i, 318i, 318iS	9.91- 5.92		333918 L 333917 R		SM1001	$\oplus$	343255	553180	$\perp$ 0,8
			 		SM1001	2,1			
316i, 318i, 318tds, 318iS Exc.	6.92- 3.98		333910 L 333909 R		SM1001	$\oplus$	343255	553180	$\perp$ 0,8
			 		SM1001	2,1			
	6.92- 3.98	OE= 31311 091 624/ 623(R/L)			SM1001	$\oplus$	343255	553180	$\perp$ 0,8
					SM1001	2,1			
320i, 325i, 325td	90- 8.91		334924 L 334923 R		SM1001	$\oplus$	343255	553180	$\perp$ 0,8
			 		SM1001	2,1			



MODEL FAHRZEUG MODELE	YEAR JAHR ANNEE	FRONT/VORNE/AVANT				REAR/HINTEN/ARRIERE			
		PREMIUM Oil	EXCEL-G* Twin-tube Gas	GAS-A-JUST Mono-tube Gas		PREMIUM Oil	EXCEL-G* Twin-tube Gas	GAS-A-JUST Mono-tube Gas	
<b>BMW (D)</b>									
<b>3 Series (E36)  ,  Exc. M-Technique sus., M3</b>									
320i, 325i, 325td	9.91- 5.92		334926 L 334925 R  	SM1001			343255	553180	 0,8
320i, 323i, 325i, 328i, 325td, 325tds Exc.	6.92- 1.95		334902 L 334901 R  	SM1001			343255	553180	 0,8
320i, 323i, 325i, 328i, 325td, 325tds Exc.	2.95- 3.98		333920 L 333919 R  	SM1001			343255	553180	 0,8
 320i, 323i, 325i, 328i, 325td, 325tds	6.92- 3.98	OE= 31311 091 624/ 623(R/L)		SM1001			343255	553180	 0,8
<b>3 Series (E36)   M-Technique sus.</b>									
316i 318i	3.91- 8.91 12.90- 8.91		333935 L 333934 R 	SM1001				553180	 0,8
316i 318i	9.91- 5.92 9.91- 5.92		333937 L 333936 R 	SM1001				553180	 0,8
316i 318i 318iS 318tds	6.92- 98 6.92- 98 6.94- 98 5.94- 98		333933 L 333932 R 	SM1001				553180	 0,8
320i 325i 325td	3.91- 8.91 12.90- 8.91 1.91- 8.91		334934 L 334933 R 	SM1001				553180	 0,8
320i 325i 325td	9.91- 5.92 9.91- 5.92 9.91- 5.92		334936 L 334935 R 	SM1001				553180	 0,8
<b>3 Series (E36)   M-Technique sus.</b>									
318iS	1.92- 5.92		333937 L 333936 R 	SM1001				553180	 0,8
320i 325i	1.92- 5.92 1.92- 5.92		334936 L 334935 R 	SM1001				553180	 0,8

\*Excel-G is a new name of SUPER  
 Excel-G ist der neue Name für SUPER  
 Excel-G est le nom nouveau pour SUPER

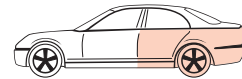
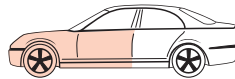

MODEL FAHRZEUG MODELE	YEAR JAHR ANNEE	FRONT/VORNE/AVANT				REAR/HINTEN/ARRIERE			
		PREMIUM Oil	EXCEL-G* Twin-tube Gas	GAS-A-JUST Mono-tube Gas		PREMIUM Oil	EXCEL-G* Twin-tube Gas	GAS-A-JUST Mono-tube Gas	
<b>BMW (D)</b>									
<b>3 Series (E36)   M-Technique sus.</b>									
316i 318iS	10.93- 99 6.92- 99		333933 L 333932 R					553180	
			SM1001						0.8
320i 323i 325i 328i	6.92- 99 2.95- 99 6.92- 99 10.94- 99		334938 L 334937 R					553180	
			SM1001						0.8
<b>3 Series (E36)  Exe. M-Technique sus.</b>									
318i 320i, 323i, 325i, 328i Exc.	1.94- 1.95 3.93- 3.98		334902 L 334901 R				343255	553180	
			SM1001  		2,1				0,8
318i Exc.	2.95- 3.98		333920 L 333919 R				343255	553180	
			SM1001  		2,1				0,8
 318i, 320i, 323i, 325i, 328i	3.93- 3.98	OE= 31311 091 624/ 623(R/L)					343255	553180	
			SM1001		2,1				0,8
<b>3 Series (E36)   M-Technique sus.</b>									
318i 320i 323i 325i 328i	1.94- 99 11.93- 99 2.95- 99 3.93- 99 11.94- 99		334938 L 334937 R					553180	
			SM1001						0.8
<b>3 Series Touring (E36)  Exe. M-Technique sus.</b>									
 Exc.	10.94- 99		333920 L 333919 R				343303▼ 343352	553239	
			SM1001  		2,1				0.8
 	10.94- 99	OE = 31311 091 624/623(R/L)							
			SM1001		2,1				0.8
<b>3 Series Touring (E36)   M-Technique sus.</b>									
318i 318tds 320i 323i 325tds 328i	11.95- 99 10.94- 99 10.94- 99 11.95- 99 10.94- 99 10.94- 99		333939 L 333938 R				343352	553239	
			SM1001						0.8
<b>3 Series (E46)  Exe. M-Technique sus.</b>									
318i 320d Exc. Sport sus.,	2.98- 9.98 4.98- 9.98		334942 L▼ 334941 R▼ 334940 L 334939 R				343303▼ 343352	553239	
									0.8



MODEL FAHRZEUG MODELE	YEAR JAHR ANNEE	FRONT/VORNE/AVANT				REAR/HINTEN/ARRIERE			
		PREMIUM Oil	EXCEL-G* Twin-tube Gas	GAS-A-JUST Mono-tube Gas		PREMIUM Oil	EXCEL-G* Twin-tube Gas	GAS-A-JUST Mono-tube Gas	
<b>BMW (D)</b>									
<b>3 Series (E46)  Exc. M-Technique sus.</b>									
⊕ Sport sus. 318i 320d	2.98- 9.98 4.98- 9.98				⊕		343352	553239	⊥ ⊕ 0.8
320i 323i 328i Exc. Sport sus.,	3.98- 9.98 3.98- 9.98 2.98- 9.98		334944 L ▼ 334943 R ▼ 334946 L 334945 R		⊕		343303 ▼ 343352	553239	⊥ ⊕ 0.8
⊕ Sport sus. 320i 323i 328i	3.98- 9.98 3.98- 9.98 2.98- 9.98				⊕		343352	553239	⊥ ⊕ 0.8
316i 318i 320d Exc. Sport sus.,	1.99- 9.98- 9.98-		334940 L 334939 R		⊕		343303 ▼ 343352	553239	⊥ ⊕ 0.8
⊕ Sport sus. 316i 318i 320d	1.99- 9.98- 9.98-				⊕		343352	553239	⊥ ⊕ 0.8
320i 323i 325i 328i 330i 330d Exc. Sport sus.,	9.98- 9.98- 00- 9.98- 00- 10.99-		334946 L 334945 R		⊕		343303 ▼ 343352	553239	⊥ ⊕ 0.8
⊕ Sport sus. 320i 323i 325i 328i 330i 330d	9.98- 9.98- 00- 9.98- 00- 10.99				⊕		343352	553239	⊥ ⊕ 0.8
<b>3 Series (E46)  Exc. M-Technique sus.</b>									
316Ci, 318Ci Exc. Sport sus.,	11.99-		334940 L 334939 R		⊕		343303 ▼ 343352	553239	⊥ ⊕ 0.8
⊕ Sport sus. 316Ci, 318Ci	11.99-				⊕		343352	553239	⊥ ⊕ 0.8
320Ci 323Ci 325Ci 328Ci Exc. Sport sus.,	8.99- 4.99- 00- 4.99-		334946 L 334945 R		⊕		343303 ▼ 343352	553239	⊥ ⊕ 0.8
⊕ Sport sus. 320Ci 323Ci 325Ci 328Ci	8.99- 4.99- 00- 9.01 4.99-				⊕		343352	553239	⊥ ⊕ 0.8

\*Excel-G is a new name of SUPER  
 Excel-G ist der neue Name für SUPER  
 Excel-G est le nom nouveau pour SUPER



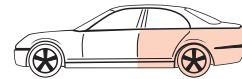
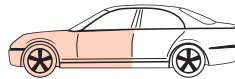

MODEL FAHRZEUG MODELE	YEAR JAHR ANNEE	FRONT/VORNE/AVANT				REAR/HINTEN/ARRIERE			
		PREMIUM Oil	EXCEL-G* Twin-tube Gas	GAS-A-JUST Mono-tube Gas		PREMIUM Oil	EXCEL-G* Twin-tube Gas	GAS-A-JUST Mono-tube Gas	
<b>BMW (D)</b>									
<b>3 Series (E46)  Exc. M-Technique sus.</b>									
318i 320d Exc. Sport sus.,	10.99- 3.00-		334940 L 334939 R		⊕		343303 ▼ 343352	553239	⊥ ⊖
⊕ Sport sus. 318i 320d	10.99- 3.00-				⊕				⊥ ⊖
320i 325i 328i Exc. Sport sus.,	10.99- 00- 10.99-		334946 L 334945 R		⊕		343303 ▼ 343352	553239	⊥ ⊖
⊕ Sport sus. 320i 325i 328i	10.99- 00- 10.99-				⊕				⊥ ⊖
330i 330d Exc. Sport sus.,	00- 10.99-				⊕		343352	553239	⊥ ⊖
⊕ Sport sus. 330i 330d	00- 10.99-				⊕		343352	553239	⊥ ⊖
<b>5 Series (E12)</b>									
518  → 4632973 520  → 4717725 520 A  → 4413736 520 i  → 4454062	74- 76 72- 76 72- 76 72- 76	665001	365021		□ 2,2	441010	341032	551011	⊥ ⊖ 0,8
518  4632974 → 520  4717726 → 520 A  4413737 → 520 i  4454063 →	76- 5.81	665001	365021 ▼ 		□ 2,2	441017	341038	551013	⊥ ⊖ 0,8
520 (6 cyl.), 528 i	9.77- 6.81		365024 ▼ 		□ 2,2			551013	⊥ ⊖ 0,8
525  → 4829406 525 A  → 4516704 528  → 4757067 528 A  → 4551948 530 i  → 5012010 530i A  → 5031674	73- 7.76	665001	365021		□ 2,2	441010	341032	551011	⊥ ⊖ 0,8
525  4829407 → 525 A  4516705 → 528  4757068 → 528 A  4551946 → 530 i  5012011 → 530i A  5031675 →	8.76- 6.81 8.76- 6.81 8.76- 80 8.76- 80 8.76- 80 8.76- 80	665001	365021 ▼ 		□ 2,2	441017	341038	551013	⊥ ⊖ 0,8





MODEL FAHRZEUG MODELE	YEAR JAHR ANNEE	FRONT/VORNE/AVANT				REAR/HINTEN/ARRIERE			
		PREMIUM Oil	EXCEL-G* Twin-tube Gas	GAS-A-JUST Mono-tube Gas		PREMIUM Oil	EXCEL-G* Twin-tube Gas	GAS-A-JUST Mono-tube Gas	
<b>BMW (D)</b>									
<b>5 Series (E28)</b>									
518, 518i, 524 D 520 i, 525 e 525 i ⊖ ABS 525 i ⊕ ABS 524 TD	7.81-12.87 7.81- 3.86 7.81- 3.86 3.82- 3.86 3.83- 3.86	665049	365043 915001 915004	SM1000	□ 2,2	441089	341144 915003	551058	⊥ ⊕ 1,2
520 i, 525 e, 524 TD 525 i ⊖ ABS 525 i ⊕ ABS 528 i, 535 i	4.86-12.87 4.86-12.87 8.81- 3.82 8.81-12.87		365043 915001 915004	SM1000	□ 2,2		341080 915003		⊥ ⊕ 1,2
<b>5 Series (E28) M5</b>									
	88- 90			SM1000					
<b>5 Series (E34)  Exc. M-Technique sus., EDC (  ), </b>									
518i, 520i Exc. Sport sus.	1.88- 7.90		365069 915001 915004	SM1000	□ 2,3		341081		⊥ ⊕ 1,2
518i, 520i Exc. Sport sus.	8.90-12.94		365083 915001 915004	SM1000	□ 2,3		341081		⊥ ⊕ 1,2
518i, 520i Exc. Sport sus.	1.95-12.95		365083 915004		□ 2,3		341081		⊥ ⊕ 1,2
⊕ Sport sus. 518i, 520i	1.88- 7.90		366005		□ 2,3		341081		⊥ ⊕ 1,2
⊕ Sport sus. 518i, 520i	8.90- 9.92		366007		□ 2,3		341081		⊥ ⊕ 1,2
⊕ Sport sus. 518i, 520i	10.92-12.95		365083		□ 2,3		341081		⊥ ⊕ 1,2
525i Incl. Sport sus.	11.87- 7.90		366005 915001 <sup>1)</sup> 915004 <sup>1)</sup>	SM1000	□ 2,3		341081		⊥ ⊕ 1,2
525i Incl. Sport sus.	8.90- 9.92		366007 915001 <sup>1)</sup> 915004 <sup>1)</sup>	SM1000	□ 2,3		341081		⊥ ⊕ 1,2
1) Exc. Sport sus.									

\*Excel-G is a new name of SUPER  
Excel-G ist der neue Name für SUPER  
Excel-G est le nom nouveau pour SUPER

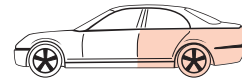
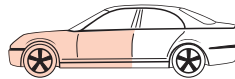

MODEL FAHRZEUG MODELE	YEAR JAHR ANNEE	FRONT/VORNE/AVANT				REAR/HINTEN/ARRIERE			
		PREMIUM Oil	EXCEL-G* Twin-tube Gas	GAS-A-JUST Mono-tube Gas		PREMIUM Oil	EXCEL-G* Twin-tube Gas	GAS-A-JUST Mono-tube Gas	
<b>BMW (D)</b>									
<b>5 Series (E34)  Exc. M-Technique sus., EDC (  ), </b>									
525i Incl. Sport sus.	10.92-12.95		365083 <sup>1)</sup> <sup>1)</sup>				341081		
525i Incl. Sport sus.	1.95-12.95		365083 <sup>1)</sup> <sup>1)</sup>				341081		
525iX (4WD) Exc. Sport sus.	1.88-12.94						341081		
530i, 535i, 524td Incl. Sport sus.	11.87- 7.90		366005 <sup>1)</sup> <sup>1)</sup>				341081		
524td, 525tds 530i, 535i, 540i	Incl. Sport sus. 8.90- 9.92 Incl. Sport sus. 8.90-12.95		366007 <sup>1)</sup> <sup>1)</sup>				341081		
525td, 525tds Incl. Sport sus.	10.92-12.95		365083 <sup>1)</sup> <sup>1)</sup>				341081		
1) Exc. Sport sus.									
<b>5 Series (E34)  Exc. M-Technique sus., EDC (  ), </b>									
518i, 520i Exc. Sport	91-12.94		365083 <sup>1)</sup> <sup>1)</sup>				341146		
518i, 520i, Exc. Sport sus.	1.95- 3.97		365083 <sup>1)</sup>				341146		
Sport sus. 518i, 520i	91- 3.97		366007				341146		
525td Exc. Sport sus.	91- 3.97		365083 <sup>1)</sup>				341146		
Sport sus. 525td	91- 3.97		366007				341146		
525tds Incl. Sport sus.	91- 3.97		366007				341146		



MODEL FAHRZEUG MODELE	YEAR JAHR ANNEE	FRONT/VORNE/AVANT				REAR/HINTEN/ARRIERE			
		PREMIUM Oil	EXCEL-G* Twin-tube Gas	GAS-A-JUST Mono-tube Gas		PREMIUM Oil	EXCEL-G* Twin-tube Gas	GAS-A-JUST Mono-tube Gas	
<b>BMW (D)</b>									
<b>5 Series (E34)  Exc. M-Technique sus., EDC (  ), </b>									
525i Incl. Sport sus.	91-12.94		366007						
			SM1000		2.3		OE =		
525i Incl. Sport sus.	1.95- 3.97		366007						
					2.3		OE =		
530i, 540i Incl. Sport sus.	91- 3.97		366007						
					2.3		OE =		
<b>5 Series (E39)  Exc. M-Technique sus., EDC (  ), </b>									
520i 523i 528i 525td 530d Exc. Sport sus.	1.96- 11.95- 9.00 11.95- 9.00 1.96- 8.98-		335916				341913		
535i 540i Exc. Sport sus.	4.96- 4.96-		335917				341913		
<b>5 Series (E39)  Exc. M-Technique sus., EDC (  ), </b>									
520i 523i 528i 525td 530d = Exc. Sport sus.	1.97- 1.97- 9.00 1.97- 9.00 6.98- 9.00-		335916				341914		
520i 523i 528i 525td 530d = Exc. Sport sus.	1.97- 1.97- 9.00 1.97- 9.00 6.98- 9.00-		335916				341915		
540i = Exc. Sport sus.	1.97-		335917				341915		
<b>6 Series (E24)</b>									
628CSi, 630CS, 633CSi	76- 6.78	665001	365021			441017	341038	551013	
		 			2.2				0.8
628CSi, 630CS, 633CSi, 635CSi	7.78- 5.82	665050	365024			441017	341038	551013	
		 			2.2				0.8

\*Excel-G is a new name of SUPER  
 Excel-G ist der neue Name für SUPER  
 Excel-G est le nom nouveau pour SUPER

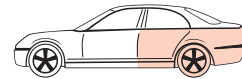
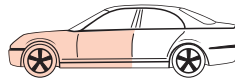

MODEL FAHRZEUG MODELE	YEAR JAHR ANNEE	FRONT/VORNE/AVANT			⌚	REAR/HINTEN/ARRIERE			⌚
		PREMIUM Oil	EXCEL-G* Twin-tube Gas	GAS-A-JUST Mono-tube Gas		PREMIUM Oil	EXCEL-G* Twin-tube Gas	GAS-A-JUST Mono-tube Gas	
<b>BMW (D)</b>									
<b>6 Series (E24)</b>									
628CSi, 633CSi, 635CSi	6.82- 90	665049	365043		⌚	441089	341144	551058	⊥ ⊕ 0,8
		 	SM1000		2,2				
630CSi	6.82- 90	665049	365043		⌚	441089	341144	551058	⊥ ⊕ 0,8
					2,2				
<b>6 Series (E24) M6</b>									
	86- 90								
			SM1000						
<b>7 Series (E23)</b>									
728, 728 i, 730, 733 i →3035000	77- 8.79	665050	365024		⌚			551030	⊥ ⊕ 1,0
		 			2,0				
728 i, 732 i, 735 i 3035001→	9.79- 9.81	665050	365024		⌚	441046	341042		⊥ ⊕ 1,2
		 			2,0				
728 i, 732 i, 735 i	10.81- 8.84	665050	365024		⌚	441047	341043		⊥ ⊕ 1,2
		 			2,0				
745 i	7.79- 8.84	665050	365024		⌚		OE=		
		 			2,0				
728 i, 732 i, 735 i	9.84- 8.86		365024		⌚		341043		⊥ ⊕ 1,0
		 			2,0				
745 i	9.84- 8.86		365024		⌚				
		 			2,0		OE=		
<b>7 Series (E32) Exc. M-Technique sus., EDC (  )</b>									
730 i, 730 iL, 735 i, 735 iL Incl. Sport sus.	9.86- 2.88		365082		⌚		341129		⊥ ⊕ 1,2
					2,3		Exc.		
730 i, 730 iL, 735 i, 735 iL Incl. Sport sus.	3.88- 7.90		366005		⌚		341129		⊥ ⊕ 1,2
					2,3		Exc.		
730 i, 730 iL 735 i, 735 iL Incl. Sport sus.	8.90- 1.92 8.90- 94		366007		⌚		341129		⊥ ⊕ 1,2
					2,3		Exc.		



MODEL FAHRZEUG MODELE	YEAR JAHR ANNEE	FRONT/VORNE/AVANT				REAR/HINTEN/ARRIERE			
		PREMIUM Oil	EXCEL-G* Twin-tube Gas	GAS-A-JUST Mono-tube Gas		PREMIUM Oil	EXCEL-G* Twin-tube Gas	GAS-A-JUST Mono-tube Gas	
<b>BMW (D)</b>									
<b>7 Series (E38) Exc. M-Technique sus., EDC (  )</b>									
725tds, 728i, 730i, 740i Exc.	4.94- 01		335907 L 335906 R		 2,5		341211 Exc.		 2,1
 725tds, 728i, 730i, 740i	4.94- 01						341211 Exc.		 2,1
728iL, 730iL, 740iL, 750iL	4.94- 01		335907 L 335906 R		 2,5		OE =		
<b>E 10 Series</b>									
1502 1600-2 Ti 2002 Ti 1602, 1802, 2000 Tii, 2002 Tii Touring 1600, 1800, 2000 Touring 1602, 1802, 2002	75- 77 66- 71 67- 75 71- 75 71- 75 71- 75	663001	363013 <u>373009</u>		 2,8	443004	343045	554002 <u>244033</u>	 0,5
<b>Series 2.5, 2.8, 3.0, 3.3 (E3)</b>									
2500, 2500 A, 2.8 i, 2.8 LA 3.0 S, 3.0 SA, 3.0 Si, 3.0 SiA 3.0 L, 3.0 LA, 3.3 L, 3.3 LA	4.71- 8.75		365002			441017	341038	551013	
2500, 2500 A, 2.8 L, 2.8 LA 3.0 S, 3.0 SA, 3.0 Si, 3.0 SiA 3.0 L, 3.0 LA, 3.3 L, 3.3 LA	9.75- 76	665050	365024		 2,2	441010	341032	551011	
<b>Z1</b>									
	10.88- 2.91		 SM1000						
<b>Z3   Exc. M-Technique sus.</b>									
1.8 1.9-16V 2.0 2.2 2.8i-V6 Exc. Sport sus.	10.95- 10.95- 4.99- 00- 4.97- 6.00		334605 L 334604 R				343330		
3.0 M3.2	6.00- 3.97- 6.01								
<b>Buick (US) ⇒ General Motors (US)</b>									
<b>Chevrolet (US) ⇒ General Motors (US)</b>									

\*Excel-G is a new name of SUPER  
 Excel-G ist der neue Name für SUPER  
 Excel-G est le nom nouveau pour SUPER

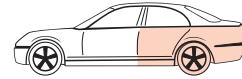
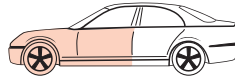

MODEL FAHRZEUG MODELE	YEAR JAHR ANNEE	FRONT/VORNE/AVANT				REAR/HINTEN/ARRIERE			
		PREMIUM Oil	EXCEL-G* Twin-tube Gas	GAS-A-JUST Mono-tube Gas		PREMIUM Oil	EXCEL-G* Twin-tube Gas	GAS-A-JUST Mono-tube Gas	
<b>Chrysler -Dodge -Plymouth (US)</b>									
<b>Le Baron, Saratoga</b>									
 Incl. GTS, GTC Exc.	86- 95		235045				343164		
<b>Neon</b>									
 Exc. Sport sus.	95-		235616				235615		
<b>PT-Cruiser</b>									
	01-		235626				343385		
<b>Stratus, Cirrus, Breeze</b>									
	95-		235610				235611		
<b>Voyager/Mini-Van, Town &amp; Country, Caravan</b>									
	84- 85						344080		
 Incl. Grand Voyager, Grand Caravan	86- 1.95		235044				344080		
 Incl. Grand Voyager, Grand Caravan	2.95- 00		334188				344080		
							Exc.	Exc.	
<b>Citroën (F)</b>									
<b>2 CV, Dyane, Mehari</b>									
2 CV AZU 250 GA Dyane 4, Dyane 6 Mehari Dyane Mehari Piste	66- 6.75 3.70- 6.75 66- 6.75 68- 6.75 5.69- 6.75						441023	551041	
									0,6
2 CV 4, 2 CV 6 Dyane 4, Dyane 6 AZU 250, 250 GA Mehari	3.70- 6.79 7.75- 6.79 7.75- 7.75-	441024					441023		
									0,6
2 CV F.A.F., Mehari AKS 400 Ami Super Berline & Break	7.79- 7.76- 12.72-	441025		551042			441026		
									0,6
<b>AX</b>									
10 E/RE, 11 E/RE, 11 TRE, 14 TRS, 14 TZS, 14 D/RD/TRD, GT	86-	665067	365087				441065	341101	
			375036			3,6		551052	
								241006	0,8



MODEL FAHRZEUG MODELE	YEAR JAHR ANNEE	FRONT/VORNE/AVANT				REAR/HINTEN/ARRIERE			
		PREMIUM Oil	EXCEL-G* Twin-tube Gas	GAS-A-JUST Mono-tube Gas		PREMIUM Oil	EXCEL-G* Twin-tube Gas	GAS-A-JUST Mono-tube Gas	
<b>Citroën (F)</b>									
<b>AX</b>									
14 RE Sport	86-		365087 375036				341101	551052 241006	
			SM1902		3,6				0,8
<b>Berlingo ⇒ See Citroën Commercial</b>									
<b>Evasion</b>									
	94- 1.98	634927	334927			443277 <sup>1)</sup>	343296 <sup>1)</sup>		
			SM1916 L SM1917 R		2,3				1,6
	1.98- 8.00	634927	334927			443303 <sup>2)</sup>	343321 <sup>2)</sup>		
			SM1916 L SM1917 R		2,3				1,6
	9.00-	634927	334927			443303 <sup>2)</sup>	343321 <sup>2)</sup>		
			SM1918 L SM1919 R		2,3				1,6
1)  L max. = 370mm      2)  L max. = 400 mm									
<b>LN, LNA</b>									
LN 602 cc	- 4.77	664004	364008						
					3,3				
LN 602 cc, 652 cc	5.77- 80	664004	364008			441041	341039		
					3,3				1,9
LNA 652 cc, 1124 cc	11.78- 86	633021	333020			441041	341039		
					3,3				1,9
<b>Saxo </b>									
1.0, 1.1, 1.4, 1.5D 1.6 Exc. 16V	2.96-	665067	365087 375036			441065	341101	551052 241006	
			SM1903		3,6				0,8
1.6-16V	2.96-		365087 375036				341101	551052 241006	
			SM1903		3,6				0,8

\* Excel-G is a new name of SUPER  
 Excel-G ist der neue Name für SUPER  
 Excel-G est le nom nouveau pour SUPER

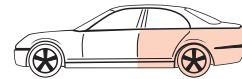
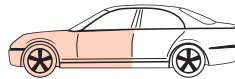

MODEL FAHRZEUG MODELE	YEAR JAHR ANNEE	FRONT/VORNE/AVANT				REAR/HINTEN/ARRIERE			
		PREMIUM Oil	EXCEL-G* Twin-tube Gas	GAS-A-JUST Mono-tube Gas		PREMIUM Oil	EXCEL-G* Twin-tube Gas	GAS-A-JUST Mono-tube Gas	
<b>Citroën (F)</b>									
<b>Visa</b>									
Visa & Visa II 1124cc	9.78- 83	633021	333020			441027	341024		
					2,8				
Visa & Visa II 1360cc Exc. GT, Challenger, Chrono	9.78- 6.84	633021	333020						
					2,8				
Chrono 1.4 Challenger 1.0 G.T 1.4	8.78- 88 2.84- 88 8.78- 86					441076	341108		
									2,2
Visa & Visa Club 652 cc 11 E, 11 RE, 1124 cc 14 RS, 14 TRS, 1360 cc Exc. GT, Chrono, Challenger	6.84- 91	633021	333020			441027	341024		
					2,8				2,2
Visa 17 D, 17 RD 1.8 Diesel	4.84- 91	633828	333828			441075	341107		
				SM1900	2,8				2,2
Visa 1.6 GTi	84- 91	634011 L 634010 R	334023 L 334022 R			441076	341108		
				SM1900	2,8				2,2
<b>Xsara  (N1/N0)</b>									
1.4,1.9 Diesel,1.9 Turbo Diesel	97- 9.00	633839 L 633838 R	333839 L 333838 R			441092	341166	551060	
			<u>323839 L</u> <u>323838 R</u>		3,0			<u>241008</u>	0,8
				SM1905 <sup>1)</sup> SM1906 <sup>2)</sup>		H/D 441093			
1.8,1.8-16V	97- 9.00	633839 L 633838 R	333839 L 333838 R			441093	341166	551060	
			<u>323839 L</u> <u>323838 R</u>		3,0			<u>241008</u>	0,8
				SM1905 <sup>1)</sup> SM1906 <sup>2)</sup>					
<b>Xsara  (N2)</b>									
1.4,1.9 Diesel,1.9 Turbo Diesel	97- 9.00	633839 L 633838 R	333839 L 333838 R			441093	341166	551060	
			<u>323839 L</u> <u>323838 R</u>		3,0			<u>241008</u>	0,8
				SM1905 <sup>1)</sup> SM1906 <sup>2)</sup>					
1)									
	2)								





MODEL FAHRZEUG MODELE	YEAR JAHR ANNEE	FRONT/VORNE/AVANT				REAR/HINTEN/ARRIERE			
		PREMIUM Oil	EXCEL-G* Twin-tube Gas	GAS-A-JUST Mono-tube Gas		PREMIUM Oil	EXCEL-G* Twin-tube Gas	GAS-A-JUST Mono-tube Gas	
<b>Citroën (F)</b>									
<b>Xsara Picasso</b>									
(N68)	10.99-		333941 L 333940 R			441066	341102	551053	
<b>ZX </b>									
1.1, 1.4 1.7 Diesel 1.9 Diesel  →5683 Exc. Turbo Diesel	91- 7.97 92- 7.97 91- 5.92	633837 L 633836 R	333837 L 333836 R	  SM1905 <sup>1)</sup> SM1906 <sup>2)</sup>	  3,0 H/D 441093	441092	341166	551060	  0,8
1.6, 1.8	91- 7.97	633839 L 633838 R	333839 L 333838 R <u>323839 L</u> <u>323838 R</u>	  SM1905 <sup>1)</sup> SM1906 <sup>2)</sup>	  3,0 H/D 441093	441092	341166	551060  <u>241008</u>	  0,8
1.9 Diesel  ABS 5684→ Exc. Turbo Diesel	6.92- 7.97	633837 L 633836 R	333837 L 333836 R	  SM1905 <sup>1)</sup> SM1906 <sup>2)</sup>	  3,0 H/D 441093	441092	341166	551060	  0,8
1.9 Diesel  ABS 5684→ Exc. Turbo Diesel	6.92- 7.97	633839 L 633838 R	333839 L 333838 R <u>323839 L</u> <u>323838 R</u>	  SM1905 <sup>1)</sup> SM1906 <sup>2)</sup>	  3,0 H/D 441093	441092	341166	551060	  0,8
1.9 Turbo Diesel Exc. Volcane	91- 7.97	633839 L 633838 R	333839 L 333838 R <u>323839 L</u> <u>323838 R</u>	  SM1905 <sup>1)</sup> SM1906 <sup>2)</sup>	  3,0 H/D 441093	441092	341166	551060	  0,8
1.9 Turbo Diesel Volcane 1.9i  5684→ 2.0i  5684→ Exc. 16V	91- 7.97 5.92- 7.97 5.92- 7.97	633839 L 633838 R	333839 L 333838 R <u>323839 L</u> <u>323838 R</u>	  SM1905 <sup>1)</sup> SM1906 <sup>2)</sup>	  3,0	441093	341166	551060	  0,8
1)		2)							

\*Excel-G is a new name of SUPER  
Excel-G ist der neue Name für SUPER  
Excel-G est le nom nouveau pour SUPER

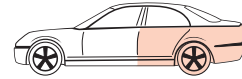
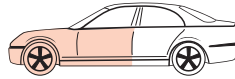

MODEL FAHRZEUG MODELE	YEAR JAHR ANNEE	FRONT/VORNE/AVANT				REAR/HINTEN/ARRIERE			
		PREMIUM Oil	EXCEL-G* Twin-tube Gas	GAS-A-JUST Mono-tube Gas		PREMIUM Oil	EXCEL-G* Twin-tube Gas	GAS-A-JUST Mono-tube Gas	
<b>Citroën (F)</b>									
<b>ZX </b>									
1.9i  → 5683 2.0i  → 5683 Exc. 16V	91- 5.92 91- 5.92	633922 L 633921 R	333922 L 333921 R			441093	341166	551060	
			SM1905 <sup>1)</sup> SM1906 <sup>2)</sup>		3,0				⊖ ⊖ 0,8
2.0 i -16V	92- 7.97		333839 L 333838 R  <u>323839 L</u> <u>323838 R</u>				341166	551060  <u>241008</u>	
			SM1905 <sup>1)</sup> SM1906 <sup>2)</sup>		3,0				⊖ ⊖ 0,8
<b>ZX </b>									
1.4i, 1.6i, 1.8i 1.9 Diesel, 1.9 Turbo Diesel	94- 7.97	633839 L 633838 R	333839 L 333838 R  <u>323839 L</u> <u>323838 R</u>			441093	341166	551060  <u>241008</u>	
			SM1905 <sup>1)</sup> SM1906 <sup>2)</sup>		3,0				⊖ ⊖ 0,8
1)	2)								
<b>Citroën Commercial (F)</b>									
<b>Berlingo</b>									
475 kg,  600 kg 	96-	633839 L 633838 R	333839 L 333838 R			441105	341237		
			SM1905 <sup>1)</sup> SM1906 <sup>2)</sup>		3,0				⊖ ⊖ 0,8
800 kg 	96-		333839 L 333838 R			441105	341237		
			SM1905 <sup>1)</sup> SM1906 <sup>2)</sup>		3,0				⊖ ⊖ 0,8
1)	2)								
<b>C 15</b>									
C15 e =	10.84- 5.88	633021	333020			441962	341962		
					2,3				⊥ ⊗ 0,6

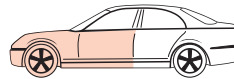

MODEL FAHRZEUG MODELE	YEAR JAHR ANNEE	FRONT/VORNE/AVANT			 ⌚	REAR/HINTEN/ARRIERE			 ⌚
		PREMIUM Oil	EXCEL-G* Twin-tube Gas	GAS-A-JUST Mono-tube Gas		PREMIUM Oil	EXCEL-G* Twin-tube Gas	GAS-A-JUST Mono-tube Gas	
<b>Citroën Commercial (F)</b>									
<b>C 15</b>									
C15 Diesel C15 e  =	10.84- 5.88-	633828	333828		 2,3	441962	341962		 ⌚ 0,6
<b>C 25</b>									
 Exc.	81-12.85	635850			 2,3	445022			 ⌚ 0,6
	81-12.85	635850			 2,3				
 Exc.  1800 kg	1.86- 94	635851			 2,3	445022			 ⌚ 0,6
 Exc. 1800 kg	1.86- 94	635851			 2,3				
<b>Jumper</b>									
27 ( 1000 kg) Incl. Exc. H/D, Camping Car	94-	635852		 SM1920 L SM1921 R	 2,3		344283		 ⌚
31 ( 1400 kg) Incl. Exc. H/D, Camping Car	94-	635852		 SM1920 L SM1921 R	 2,3		344284		 ⌚
35 ( 1800 kg)  Exc. H/D, Camping Car	94-	635853		 SM1920 L SM1921 R	 2,3		345021		 ⌚
<b>Jumpy</b>									
	96- 8.97	634928	334928	 SM1916 L SM1917 R	 2,3	441106 <sup>1)</sup>	341238 <sup>1)</sup>		 ⌚
	9.97- 8.00	634928	334928	 SM1916 L SM1917 R	 2,3	441107 <sup>2)</sup>	341239 <sup>2)</sup>		 ⌚
	9.00-	634928	334928	 SM1918 L SM1919 R	 2,3	441107 <sup>2)</sup>	341239 <sup>2)</sup>		 ⌚
1)  L max. = 370mm                2)  L max. = 400 mm									

\* Excel-G is a new name of SUPER  
 Excel-G ist der neue Name für SUPER  
 Excel-G est le nom nouveau pour SUPER



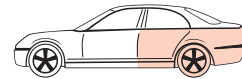
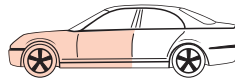

MODEL FAHRZEUG MODELE	YEAR JAHR ANNEE	FRONT/VORNE/AVANT				REAR/HINTEN/ARRIERE			
		PREMIUM Oil	EXCEL-G* Twin-tube Gas	GAS-A-JUST Mono-tube Gas		PREMIUM Oil	EXCEL-G* Twin-tube Gas	GAS-A-JUST Mono-tube Gas	
<b>Daewoo (KO)</b>									
<b>Espero</b>									
1.5 1.8 2.0	92- 9.99	665036	365025 <u>375009</u>		 2,1	443134	343047	553075 <u>243014</u>	 0,6
SM1307									
<b>Lanos</b>									
	97-	665036	365025 <u>375009</u>			443134	343047	553075 <u>243014</u>	
<b>Leganza</b>									
 Incl. ⊕ ABS	97-	634096 L 634095 R	334212 L 334211 R			634098 L 634097 R	334214 L 334213 R		
<b>Matiz</b>									
 Incl. ⊕ ABS	4.98-	632117 L 632116 R	332101 L 332100 R			443301	343304		
<b>Musso</b>									
 Incl.	10.93-		344309	554146			344310	554147	
<b>Nexia/Cielo</b>									
1.5, 1.5 -16V 1.8	95-	665036	365025 <u>375009</u>		 2,1	443134	343047	553075 <u>243014</u>	 0,6
SM1307									
<b>Nubira</b> ,  ,									
 Incl. ⊕ ABS KLAJ .... EV	97- 7.97	634092 L 634091 R	334208 L 334207 R			633203 L 633202 R	333255 L 333254 R		
 Incl. ⊕ ABS KLAJ .... EW,EX,EY,...	8.97- 5.99	634094 L 634093 R	334210 L 334209 R			633203 L 633202 R	333255 L 333254 R		
<b>Nubira II</b> ,  ,									
 Incl. ⊕ ABS	6.99-	634094 L 634093 R	334210 L 334209 R			633203 L 633202 R	333255 L 333254 R		
<b>Tico</b>									
	96-	632094 L 632093 R					342018		



MODEL FAHRZEUG MODELE	YEAR JAHR ANNEE	FRONT/VORNE/AVANT				REAR/HINTEN/ARRIERE			
		PREMIUM Oil	EXCEL-G* Twin-tube Gas	GAS-A-JUST Mono-tube Gas		PREMIUM Oil	EXCEL-G* Twin-tube Gas	GAS-A-JUST Mono-tube Gas	
<b>Daihatsu (J)</b>									
<b>Applause</b>									
1.6   (A 101) Incl. Hard sus., Auto adjust sus.	6.89-		333171 L 333170 R				333173 L 333172 R		
					1,7				1,7
1.6   (A 111) Incl. Hard sus., Auto adjust sus.	6.89-		333171 L 333170 R				333175 L 333174 R		
					1,7				1,7
<b>Charade</b>									
 (G 10 series)	77- 5.78	633024 L 633023 R				441037	341013		
 (G 10 series)	6.78- 8.79	633026 L 633025 R				441037	341013		
 (G 10 series)	8.79- 1.83	633013 L 633012 R				441037	341013		
									1,6
 (G 11, 30 series)	1.83- 86	632029 L 632028 R				442027			
					1,8				1,4
 1000 (G100) Exc. Turbo, GT-ti 1000 Diesel, Turbo Diesel (G101) 1300  R-Grade Package (G102)	1.87- 2.93 1.87- 2.93 9.88- 2.93	632045 L 632044 R	332044 L 332043 R			632090 L 632089 R	332067 L 332066 R		
					1,8				
 1000 Turbo (G100) Exc. GT-ti 1300  R-Grade Package (G102)	1.87- 8.88 9.88- 2.93		332044 L 332043 R				332067 L 332066 R		
					1,8				
 1300 (G102)	5.89- 2.93	632045 L 632044 R	332044 L 332043 R			633132 L 633131 R	333154 L 333153 R		
					1,8				
 1000 GT-ti (G100)	1.87- 2.93		332044 L 332043 R				332046 L 332045 R		
					1,8				
 1300 (G112)	9.88- 2.93								
 1000 (G202) 1300 (G200) 1500 (G203) Incl.  ABS	5.93- 6.96 3.93- 6.96 6.94- 6.96	632102 L 632101 R	332079 L 332078 R			633176 L 633175 R	333200 L 333199 R		
 1000 (G202) 1300 (G200) Incl.  ABS	6.96- 6.96-		333245 L 333244 R				333247 L 333246 R		
 1500 (G203) Incl.  ABS	6.96-		333245 L 333244 R				333247 L 333246 R		

Daihatsu

\*Excel-G is a new name of SUPER  
Excel-G ist der neue Name für SUPER  
Excel-G est le nom nouveau pour SUPER



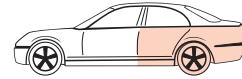
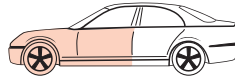

MODEL FAHRZEUG MODELE	YEAR JAHR ANNEE	FRONT/VORNE/AVANT				REAR/HINTEN/ARRIERE			
		PREMIUM Oil	EXCEL-G* Twin-tube Gas	GAS-A-JUST Mono-tube Gas		PREMIUM Oil	EXCEL-G* Twin-tube Gas	GAS-A-JUST Mono-tube Gas	
<b>Daihatsu (J)</b>									
<b>Charade</b>									
1600 GTi (G201) Incl. ⊕ ABS	3.93-		332079 L 332078 R		⊕		333200 L 333199 R		⊕
<b>Charmant </b>									
(A 10, 20) (A 30, 40)	11.74- 2.78 2.77- 7.81	663031	363018		⊥ 4,2	443097	343035	553054	⊥ ⊕ 0,8
1300 (A 35) 1500 (A 55)	10.81- 8.83	663032	363023		⊥ 4,2	443099	343036	553056	⊥ ⊕ 0,8
1600 (A 45) 1300 (A 35), 1600 (A 60)	10.81- 8.83 9.83- 88	665022	365015		⊥ 4,2	443099	343036	553056	⊥ ⊕ 0,8
<b>Charmant </b>									
 (A 10 V, 20 V, 30 V)	12.74- 2.78	663031			⊥	443065			⊥ ⊕
1300 (A 30V) 1600 (A 40V)	8.79- 7.81	663031			⊥ 4,2	443176			⊥ ⊕
<b>Cuore/Domino</b>									
 Exc. Van (L 55)	6.80-12.85	633017 L 633016 R			⊕	443175			⊥ ⊕ 1,0
Van (L 55 V)	6.80-12.85	633017 L 633016 R			⊕				⊕ ⊕
840 cc (L80)	8.85- 7.90	632057 L 632056 R			⊕	442032			⊥ ⊕
850 cc (L201)	8.90- 8.94	632098 L 632097 R			⊕	442033			⊕ ⊕
850 cc (L501)	8.94-10.98	632100 L 632099 R			⊕	442034			⊕ ⊕
1000 cc Incl. ⊕ ABS (L701)	10.98-	632119 L 632118 R	332103 L 332102 R		⊕	442038	342022		⊕ ⊕
<b>Delta (Truck)</b>									
Delta (V 10 T)	8.77- 9.84	444064			⊥ ⊕	444061			⊕ ⊕

Daihatsu



MODEL FAHRZEUG MODELE	YEAR JAHR ANNEE	FRONT/VORNE/AVANT				REAR/HINTEN/ARRIERE			
		PREMIUM Oil	EXCEL-G* Twin-tube Gas	GAS-A-JUST Mono-tube Gas		PREMIUM Oil	EXCEL-G* Twin-tube Gas	GAS-A-JUST Mono-tube Gas	
<b>Daihatsu (J)</b>									
<b>Feroza</b>									
F 300 Exc.	10.88-		344105	554063			343238	553156	
F 310 Exc.	5.92-		344105	554063			343275	553196	
<b>Gran Move</b>									
1500 1600 Incl.	(G303) (G301) 8.95- 7.98-		333245 L 333244 R				333247 L 333246 R		
<b>Hijet</b>									
Cab, Van (S 38, 40 series)	9.71- 5.81	442019				442020			
Cab, Van (S 60 series) Exc. separate box, Low deck type	2.78- 3.81	443242				442020			
<b>Move</b>									
850 cc (L601)	8.95-10.98		333249 L 333248 R				342021		
1000 cc (L901)	10.98-		332103 L 332102 R				342022		
<b>Sirion/Storia</b>									
 1.0 (M100)	1.98- 4.99		332105 L 332104 R				342022		
 1.0 ( → M100 - 538945)	(M100) 4.99-		332105 L 332104 R				342022		
 1.0 ( M100 - 538946 →) 1.3	(M100, M101) - 5.00-		332111 L 332110 R				342022		
 1.0 (M110)	1.98- 4.99		332105 L 332104 R				342023		
 1.0 ( → M110 - 542039)	(M110) 4.99-		332105 L 332104 R				342023		
 1.0 ( M110 - 542040 →) 1.3	(M110, M111) - 5.00-		332111 L 332110 R				342023		

Daihatsu

\*Excel-G is a new name of SUPER  
Excel-G ist der neue Name für SUPER  
Excel-G est le nom nouveau pour SUPER



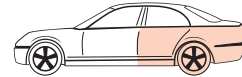
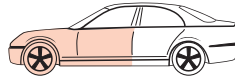

MODEL FAHRZEUG MODELE	YEAR JAHR ANNEE	FRONT/VORNE/AVANT				REAR/HINTEN/ARRIERE			
		PREMIUM Oil	EXCEL-G* Twin-tube Gas	GAS-A-JUST Mono-tube Gas		PREMIUM Oil	EXCEL-G* Twin-tube Gas	GAS-A-JUST Mono-tube Gas	
<b>Daihatsu (J)</b>									
<b>Taft/Rocky/Wild Cat/Four Track</b>									
(F 10, 20, 50)	8.78- 84	443152		553144	○ ○	443150		553143	○ ○
(F 25, 55)	11.79- 84	443152		553144	○ ○	443151		553096	○ T
(F 60)	10.82- 84	443177		553145	○ ○	443150		553143	○ ○
(F 70, F 75, F 80, F 85) Exc.	4.84- 4.93		343186	553113	⊥ ○ 1,0		343186	553113	⊥ ○ 1,4
(F 77, F 87) Exc.	4.84- 4.93		343186	553113	⊥ ○ 1,0	443151		553096	○ T
(F 73, F 78) Exc.	5.93-		344257	554089	⊥ ⊖		344258	554090	⊥ ⊖
<b>Terios</b>									
1300 Incl. ⊕ ABS	(J100) 3.97- 7.98				⊕		342024		○ ⊖
1300 Incl. ⊕ ABS	(J100) 8.98-				⊕				○ ⊖
<b>YRV</b>									
1.0, 1.3	(M2) 10.00-		332111 L 332110 R		⊕		342022		⊖ ⊖
1.3	(M2) 10.00-		332111 L 332110 R		⊕		342023		⊖ ⊗
<b>Dodge (US) ⇒ Chrysler (US)</b>									
<b>Fiat (I)</b>									
500, D, F, L, Nuova	59- 76	443005	343070		⊥	443006	343071		⊥
<b>124, 125, 126, 127, 128</b>									
124 S, T 	68- 76	443007	343072	553003	⊥ ⊖ 2,5	443008	343017	553004	⊥ ⊖ 1,1





MODEL FAHRZEUG MODELE	YEAR JAHR ANNEE	FRONT/VORNE/AVANT				REAR/HINTEN/ARRIERE			
		PREMIUM Oil	EXCEL-G* Twin-tube Gas	GAS-A-JUST Mono-tube Gas		PREMIUM Oil	EXCEL-G* Twin-tube Gas	GAS-A-JUST Mono-tube Gas	
<b>Fiat (I)</b>									
<b>124, 125, 126, 127, 128</b>									
124 Familiare 	66- 2.75	443007	343072	553003	$\perp$ $\ominus$ 2,5	443123	343098	553005	$\circ$ $\ominus$
125, 125 S	2.67- 6.72	443010	343074		$\perp$ $\ominus$ 1,0	443011	343075	553148	$\perp$ $\circ$
126 Exc. Bis	72-	443005	343070		$\perp$ 0,8	443006	343071		$\perp$ 0,8
127 Exc. Diesel, Fiorino	71-10.83	633002	333014		$\oplus$ 1,1	633003	333005		$\oplus$ 1,2
128 	69-12.82	633004	333013		$\oplus$ 1,1	633005	333015		$\oplus$ 1,0
<b>131 </b>									
 →4214186	74- 2.78	633006	333016		$\oplus$ 1,1	443008	343017	553004	$\perp$ $\ominus$ 1,1
 4214186→	3.78- 2.81	633007	333017		$\oplus$ 1,1	443008	343017	553004	$\perp$ $\ominus$ 1,1
 	3.81-12.83					443008	343017	553004	$\perp$ $\ominus$ 1,1
Diesel →1012811	7.78- 2.81	633008	333018		$\oplus$ 1,1	443008	343017	553004	$\perp$ $\ominus$ 1,1
Diesel 1012811→	3.81-12.83				$\oplus$	443008	343017	553004	$\perp$ $\ominus$ 1,1
<b>132/Argenta</b>									
132 Argenta	72- 86 81- 86	443013	343018	553006	$\perp$ $\ominus$ 0,7	443014	343019	554005	$\perp$ $\ominus$ 1,1
<b>Barchetta</b>									
1.8	3.95-		334867		$\oplus$			554086	$\ominus$ $\ominus$
<b>Bravo, Brava </b>									
1.4 →4085697	95- 96		333842 SM1806		$\oplus$		344115	554077	$\ominus$ $\ominus$

\* Excel-G is a new name of SUPER  
Excel-G ist der neue Name für SUPER  
Excel-G est le nom nouveau pour SUPER

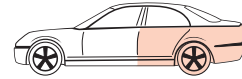
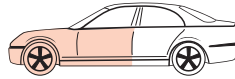

MODEL FAHRZEUG MODELE	YEAR JAHR ANNEE	FRONT/VORNE/AVANT				REAR/HINTEN/ARRIERE			
		PREMIUM Oil	EXCEL-G* Twin-tube Gas	GAS-A-JUST Mono-tube Gas		PREMIUM Oil	EXCEL-G* Twin-tube Gas	GAS-A-JUST Mono-tube Gas	
<b>Fiat (I)</b>									
<b>Bravo, Brava </b>									
1.4 4085698→	1.96- 01		333868 ▼ 333711		+		344115	554077	⊖
			SM1806						⊖
1.2, 1.6	95- 01		333868 ▼ 333711		+		344115	554077	⊖
			SM1806 <sup>1)</sup> SM1802 L <sup>2)</sup> SM1803 R <sup>2)</sup>						⊖
1.9D, 2.0D	95- 01		333868 ▼ 333711		+		344115	554077	⊖
			SM1806						⊖
1.8 1.9 TD, 1.9JTD	95- 01		334859 ▼ 334809		+		344115	554077	⊖
			SM1806						⊖
2.0-20V Exc. Sport sus.	95- 01		334860		+			554077	⊖
			SM1806						⊖
2.0-20V ⊕ Sport sus.	95- 01				+			554077	⊖
			SM1802 L SM1803 R						⊖
1) Bravo                      2) Brava									
<b>Chinquecento</b>									
0.7, 0.9	92- 3.98	632800	332800 <u>322800</u>		+	441098	341189 <u>351019</u>		⊖ ⊗ 0,7
			915809						
1.1 Incl. Sporting	94- 3.98		332800 <u>322800</u>		+		341189 <u>351019</u>		⊖ ⊗ 0,7
<b>Coupé</b>									
2.0-16V, 2.0-20V, 2.0 Turbo	94-				+		344115	554077	⊖
									⊖
<b>Croma (154)</b>									
1.6, 2.0 1.9TD, 2.5D, 2.5TD	12.85-10.86		334804		+				+
			SM1807						



MODEL FAHRZEUG MODELE	YEAR JAHR ANNEE	FRONT/VORNE/AVANT				REAR/HINTEN/ARRIERE			
		PREMIUM Oil	EXCEL-G* Twin-tube Gas	GAS-A-JUST Mono-tube Gas		PREMIUM Oil	EXCEL-G* Twin-tube Gas	GAS-A-JUST Mono-tube Gas	
<b>Fiat (I)</b>									
<b>Croma (154)</b>									
2.0 i.e., 2.0 i.e. Turbo	12.85-10.86		334804		+				+
			SM1808		1.1				
1.6, 2.0 1.9 TD, 2.5 D, 2.5 TD 2.0 TD	11.86- 11.86- 88-		334804		+		334801		+
			SM1807		1.1				2.1
2.0 i.e., 2.0 i.e. Turbo	11.86-		334804		+		334801		+
			SM1808		1.1				2.1
<b>Doblo =&gt; See Fiat Commercial</b>									
<b>Idea</b>									
=	03-		334871		+				
= Diesel	03-		334872		+				
<b>Marea </b>									
1.4, 1.6, 1.8 1.9TD -75, 100	96-		334861		+		344115	554077	
			SM1806						
2.0-20V, 2.4 TD	96-		334862		+			554077	
			SM1806						
<b>Multipla</b>									
1.6 1.9TD	10.98-		334863		+		344115	554077	
<b>Palio </b>									
 Incl.  ABS	(178BX) 4.96-		333942		+				
<b>Palio Weekend </b>									
 Incl.  ABS Exc. 1.9D	2.98-		333942		+		344115	554077	
<b>Panda (141)</b>									
 	2.80- 1.86	633811 ▼ 633951	333811 ▼ 333951		+	441038	341212		 0,4
			SM1804		1,1				
 	2.86-	633811 ▼ 633951	333811 ▼ 333951		+	441077	341209		 0,4
			SM1804		1,1				

\*Excel-G is a new name of SUPER  
Excel-G ist der neue Name für SUPER  
Excel-G est le nom nouveau pour SUPER

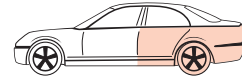
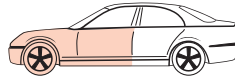

MODEL FAHRZEUG MODELE	YEAR JAHR ANNEE	FRONT/VORNE/AVANT				REAR/HINTEN/ARRIERE			
		PREMIUM Oil	EXCEL-G* Twin-tube Gas	GAS-A-JUST Mono-tube Gas		PREMIUM Oil	EXCEL-G* Twin-tube Gas	GAS-A-JUST Mono-tube Gas	
<b>Fiat (I)</b>									
<b>Panda (141)</b>									
 	87-		333871 SM1804			441094	341210		  0,4
<b>Punto </b>									
1.1i 55 1.2i 60, 75, 85 1.6i 90 Exc. 1.2 85 Sporting, 1.6 90 Sporting	93- 9.99		333843 <u>324805</u> SM1805	 1,4			343269	554086 <u>244039</u>	  0,9
1.7 Diesel 1.7 Turbo Diesel	93- 9.99		334805 <u>324805</u> SM1805	 1,4			343269	554086 <u>244039</u>	  0,9
1.4i GT Turbo 1.2 85 Sporting 1.6 90 Sporting	93- 9.99 97- 9.99 95- 9.99		334805 <u>324805</u> SM1805	 1,4				554086 <u>244039</u>	  0,9
1.2, 1.2-16V Exc. 1.2-16V Sporting	9.99-		334864				343329		 
1.9 JTD	9.99-		334865				343329		 
1.8-16V 1.2-16V Sporting	9.99-		334866				343329		 
<b>Regata (138 R) </b>									
60, 70, 70 S, 70 ES, 75, 75 S 75 i.e., 75 S i.e. 85, 85 S, 100 S	9.83- 90 85- 90 9.83- 90	633048	333048 	 1,1		633044	333047		 1,0
Diesel Diesel Super, Turbo Diesel	9.83- 90 9.84- 90					633044	333047		 1,0
<b>Regata Weekend (138 R) </b>									
70, 70 S, 70 ES, 100 S Exc. Diesel	9.84- 90	633048	333048 	 1,1					
<b>Ritmo/Strada (138) </b>									
60, 65, 75, 85 Diesel	78- 9.82 79- 9.82	633019	333009 SM1804	 1,1		633044	333047		 1,0
Super 75, 85 105 TC	81- 9.82	633019	333009 SM1804	 1,1		633815	333815		 1,0



MODEL FAHRZEUG MODELE	YEAR JAHR ANNEE	FRONT/VORNE/AVANT				REAR/HINTEN/ARRIERE			
		PREMIUM Oil	EXCEL-G* Twin-tube Gas	GAS-A-JUST Mono-tube Gas		PREMIUM Oil	EXCEL-G* Twin-tube Gas	GAS-A-JUST Mono-tube Gas	
<b>Fiat (I)</b>									
<b>Ritmo/Strada (138)</b>									
125 TC	81- 9.82					633815	333815		
				SM1804					1,0
60, 60 ES, Super 60 70, Super 70, 75, Super 75 85, Super 85 (E No. 4378022-) 75 i.e., 75 S i.e.	10.82- 88 10.82- 88 10.82- 88 6.85- 88	633048	333048			633044	333047		
					1,1				1,0
Diesel Turbo Diesel	10.82- 88 85- 88					633044	333047		
									1,0
<b>Seicento</b>									
 Incl. Sporting	98-		333870			441098	341189		
<b>Stilo</b>									
 Exc. 2.4-20V	01-		334869						
2.4-20V	01-		334870						
<b>Talento</b>									
 Exc.	88-	635851				445022			
				SM1801	2,5				
	88-	635851							
				SM1801	2,5				
<b>Tempra (159)</b>									
1.4, 1.6, 1.6 ie	90- 96		333842			444100	344115	554077	
					1,1			<u>244040</u>	
				SM1802 L SM1803 R					0,7
1.8, 2.0 ie, 1.9 Diesel 1.9 Turbo Diesel	90- 96		334806				344115	554077	
					1,1			<u>244040</u>	
				SM1802 L SM1803 R					0,7
<b>Tempra Station Wagon/Familia (159)</b>									
1.4, 1.6, 1.6 ie Exc.	90- 96		333842				344115	554077	
					1,1			<u>244040</u>	
				SM1802 L SM1803 R					0,7

\*Excel-G is a new name of SUPER  
Excel-G ist der neue Name für SUPER  
Excel-G est le nom nouveau pour SUPER

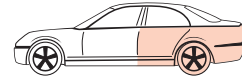
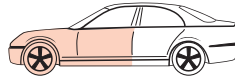

MODEL FAHRZEUG MODELE	YEAR JAHR ANNEE	FRONT/VORNE/AVANT				REAR/HINTEN/ARRIERE			
		PREMIUM Oil	EXCEL-G* Twin-tube Gas	GAS-A-JUST Mono-tube Gas		PREMIUM Oil	EXCEL-G* Twin-tube Gas	GAS-A-JUST Mono-tube Gas	
<b>Fiat (I)</b>									
<b>Tempra Station Wagon/Familia (159)</b>									
1.8, 2.0 ie, 1.9 Diesel, 1.9 Turbo Diesel Exc.	90- 96		334806 <u>324806</u> 	SM1802 L SM1803 R	 1,1		344115	554077 <u>244040</u>	 0,7
<b>Tipo (160)</b>									
1.1, 1.4, 1.6, 1.6 ie, 1.7 D, 1.9 D	4.88- 95		333842 <u>324806</u> 	SM1802 L SM1803 R	 1,1	444100	344115	554077 <u>244040</u>	 0,7
1.8, 1.8 ie, 1.8 ie-16V, 1.9 TD 2.0 ie, 2.0 ie-16V	1.88- 95 90- 95		334806 <u>324806</u> 	SM1802 L SM1803 R	 1,1		344115	554077 <u>244040</u>	 0,7
<b>Ulyse</b>									
	94- 1.98	634927	334927	SM1916 L SM1917 R	 2.3	443277 <sup>1)</sup>	343296 <sup>1)</sup>		 1.6
	1.98- 8.00	634927	334927	SM1916 L SM1917 R	 2.3	443303 <sup>2)</sup>	343321 <sup>2)</sup>		 1.6
	9.00- 7.02	634927	334927	SM1918 L SM1919 R	 2.3	443303 <sup>2)</sup>	343321 <sup>2)</sup>		 1.6
1)  L max. = 370mm                2)  L max. = 400 mm									
<b>Uno (146)</b>									
45 (0.9, 1.0) 55 (1.1) 60 (1.1) 70 (1.3) 75 ie (1.5) Diesel (1.3) CS (1.1)	83- 94 83- 6.85 7.85- 94 1.83- 94 3.85- 94 5.83- 94 83- 94	633833	333833 <u>323035</u> 	SM1800	 1,1	443271	343189 <u>353010</u>	553134	 0,8
Turbo Diesel (1.4) Diesel (1.7, 1.9)	86- 94 7.85- 94		333833 <u>323035</u> 	SM1800	 1,1	443271	343189 <u>353010</u>	553134	 0,8



MODEL FAHRZEUG MODELE	YEAR JAHR ANNEE	FRONT/VORNE/AVANT				REAR/HINTEN/ARRIERE			
		PREMIUM Oil	EXCEL-G* Twin-tube Gas	GAS-A-JUST Mono-tube Gas		PREMIUM Oil	EXCEL-G* Twin-tube Gas	GAS-A-JUST Mono-tube Gas	
<b>Fiat (I)</b>									
<b>Uno (146)</b>									
Turbo ie (1.3, 1.4) Exc. ⊕ ABS	4.85- 94		333833 <u>323035</u>		⊕ 1,1	443271	343189 <u>353010</u>	553134	⊕ 0,8
<b>X 1/9 (128 AS)</b>									
1300	72- 78	663013	363017		⊖	663013	363017		⊖
1500	78- 82	663013	363017		⊖				
<b>Fiat Commercial (I)</b>									
<b>Doblo, Doblo Cargo  Exc. Turquie, Israel</b>									
⊖ ABS 1242 MPI 8V Exc. Panorama, Panorama elegant	12.00-				⊕		345031		⊖
⊖ ABS 1.9 DS 1910 JTD Exc. Panorama, Panorama elegant	12.00-				⊕		345031		⊖
⊖ ABS 1242 MPI 8V Panorama, Panorama elegant	12.00-				⊕		345031		⊖
⊖ ABS 1.9 DS 1910 JTD Panorama, Panorama elegant	12.00-				⊕		345031		⊖
⊕ ABS 1242 MPI 8V Exc. Panorama, Panorama elegant	12.00-				⊕		345031		⊖
⊕ ABS 1.9 DS 1910 JTD Exc. Panorama, Panorama elegant	12.00-				⊕		345031		⊖
⊕ ABS 1242 MPI 8V Panorama, Panorama elegant	12.00-				⊕		345031		⊖
⊕ ABS 1.9 DS 1910 JTD Panorama, Panorama elegant	12.00-				⊕		345031		⊖
<b>Doblo, Doblo Cargo  For Turquie, Israel Model</b>									
1.9 DS Fourgon base, Fourgon elegant	12.00-				⊕		345032		⊖

\*Excel-G is a new name of SUPER  
 Excel-G ist der neue Name für SUPER  
 Excel-G est le nom nouveau pour SUPER

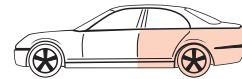
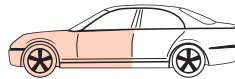

MODEL FAHRZEUG MODELE	YEAR JAHR ANNEE	FRONT/VORNE/AVANT				REAR/HINTEN/ARRIERE			
		PREMIUM Oil	EXCEL-G* Twin-tube Gas	GAS-A-JUST Mono-tube Gas		PREMIUM Oil	EXCEL-G* Twin-tube Gas	GAS-A-JUST Mono-tube Gas	
<b>Fiat Commercial (I)</b>									
<b>Ducato (2WD)</b>									
Exc.  , → 0284193	81- 4.84	635850				445022			
				SM1801	2,5				
Exc.  , 0284194 →	5.84- 5.86	635851				445022			
				SM1801	2,5				
,	81- 4.84	635850							
				SM1801	2,5				
Exc. Maxi () ,  ,	6.86- 94	635851				445022			
				SM1801	2,5				
, Exc. Maxi ()	5.84- 94	635851							
				SM1801	2,5				
Express 10-13-15	6.86- 94	635851				445022			
				SM1801	2,5		= 570mm		
10Q () Incl. Exc. H/D, Camping Car	94-	635852					344283		
				SM1920 L SM1921 R	2,5				
14Q () Incl. Exc. H/D, Camping Car	94-	635852					344284		
				SM1920 L SM1921 R	2,5				
18Q () Incl. Exc. H/D, Camping Car	94-	635853					345021		
				SM1920 L SM1921 R	2,5				
Camping Car Grand Export	94-	635853							
				SM1920 L SM1921 R	2,5				
<b>Fiorino </b>									
ABS	93-	633873					341324		
ABS	93-	633873					341324		
<b>Scudo</b>									
	96- 8.97	634928				441106 <sup>1)</sup>	341238 <sup>1)</sup>		
				SM1916 L SM1917 R					





MODEL FAHRZEUG MODELE	YEAR JAHR ANNEE	FRONT/VORNE/AVANT				REAR/HINTEN/ARRIERE			
		PREMIUM Oil	EXCEL-G* Twin-tube Gas	GAS-A-JUST Mono-tube Gas		PREMIUM Oil	EXCEL-G* Twin-tube Gas	GAS-A-JUST Mono-tube Gas	
<b>Fiat Commercial (I)</b>									
<b>Scudo</b>									
	9.97- 8.00	634928	334928		+	441107 <sup>2)</sup>	341239 <sup>2)</sup>		
			SM1916 L SM1917 R						
	9.00-	634928	334928		+	441107 <sup>2)</sup>	341239 <sup>2)</sup>		
			SM1918 L SM1919 R						
1)  L max. = 370mm                2)  L max. = 400 mm									
<b>Fiat Polski (PL)</b>									
101 P Zastava		633004	333013		+	633005	333015		+
125 P	74- 84	443010	343074			443011	343075	553148	
126 P	74-	443005	343070			443006	343071		
127 P		633002	333014		+	633003	333005		+
132 P	74-	443013	343018	553006		443014	343019	554005	
Polonez 1500	79- 83	443013	343018			443204	343178		

\*Excel-G is a new name of SUPER  
 Excel-G ist der neue Name für SUPER  
 Excel-G est le nom nouveau pour SUPER

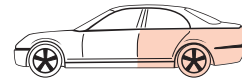
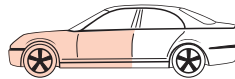

MODEL FAHRZEUG MODELE	YEAR JAHR ANNEE	FRONT/VORNE/AVANT				REAR/HINTEN/ARRIERE			
		PREMIUM Oil	EXCEL-G* Twin-tube Gas	GAS-A-JUST Mono-tube Gas		PREMIUM Oil	EXCEL-G* Twin-tube Gas	GAS-A-JUST Mono-tube Gas	
<b>Ford (Europe)</b>									
<b>Capri</b>									
Capri I 1.3, 1.6, 2.0, 2.3 Capri II 1.3, 1.6, 2.0, 2.3, 2.6 Capri III 1.6, 2.0, 2.3, 3.0 Exc. 2.8i	7.72- 2.74 12.73- 3.78 4.78-12.86	665004	365018		 2,4	443022	343046	554010	 ⊥ ⊕ 0,6
<b>Consul</b>									
1.7, 2.0, 2.3, 2.5, 3.0	71- 9.75	443018	343003	553008	 ⊕ ⊕ 0,7	443019	343004	554007	 ⊥ ⊕ 0,7
<b>Cortina</b>									
Mk II 1.3, 1.6, 1.6 E, 1.6 ST, Executive, GT	8.67-10.70	665028				443023	343079		 ⊥ ⊕
Mk II 1.3, 1.6	8.67-10.70	665028							
Mk III, Mk IV 1.3, 1.6, 2.0, 2.3	71- 82	443016	343001	553007	 ⊕ ⊕ 0,7	443017	343002	554006	 ⊕ ⊕ 0,6
<b>Cougar</b>									
	8.98-		335918				335919		
<b>Escort MK. I, II (68-80)</b>									
Mk. I 0.9, 1.1, 1.3, GT	8.68- 9.73	663003	363042		 2,6	443020	343078	554008	 ⊕ ⊕ 0,6
Mk. I 0.9, 1.1, 1.3 Incl. Sport	10.73- 74	663004	363004		 2,6	443021	343020	554009	 ⊥ ⊕ 0,6
Mk. I 0.9, 1.1, 1.3	10.73- 74	663004	363004		 2,6	443020	343078	554008	 ⊕ ⊕ 0,6
Mk. II 0.9, 1.1, 1.3, 1.6 Incl. Sport	1.75- 8.80	663004	363004		 2,6	443021	343020	554009	 ⊥ ⊕ 0,6
Mk. II 0.9, 1.1, 1.3, 1.6	1.75- 8.80	663004	363004		 2,6	443109			 ⊕ ⊕ 0,6
<b>Escort MK. III, XR-3 (80-90)</b>									
Mk. III 1.1, 1.3, 1.6 Exc. XR-3	9.80- 4.83	633801	333801		 1,0	632801	332801 323036		 ⊕ ⊕ 0,9



MODEL FAHRZEUG MODELE	YEAR JAHR ANNEE	FRONT/VORNE/AVANT				REAR/HINTEN/ARRIERE			
		PREMIUM Oil	EXCEL-G* Twin-tube Gas	GAS-A-JUST Mono-tube Gas		PREMIUM Oil	EXCEL-G* Twin-tube Gas	GAS-A-JUST Mono-tube Gas	
<b>Ford (Europe)</b>									
<b>Escort MK. III, XR-3 (80-90)</b>									
Mk. III 1.1, 1.3, 1.4, 1.6 Exc. XR-3 1.6 Diesel	5.83-12.84 5.84-12.84	633802	333802 <u>323024</u> 			632801	332801 <u>323036</u> 		
Mk. III 1.1, 1.3, 1.4, 1.6 Exc. XR-3	1.85- 7.90	633802	333802 <u>323024</u> 			632801	332801 <u>323036</u> 		
Mk. III 1.6 Diesel Exc. XR-3	1.85-12.85	633802	333802 <u>323024</u> 			632801	332801 <u>323036</u> 		
Mk. III 1.3/1.6 Petrol	5.84-12.84	633834	333834 <u>323024</u> 			632801	332801 <u>323036</u> 		
Mk. III 1.3/1.6 Petrol	1.85-12.85	633834	333834 <u>323024</u> 			632801	332801 <u>323036</u> 		
Mk. III 1.6 Diesel, 1.8 Diesel	1.86- 7.90	633834	333834 <u>323024</u> 			632801	332801 <u>323036</u> 		
Mk. III XR-3 RS Turbo	5.83-12.84 10.84-12.84		333802 <u>323024</u> 				333079 <u>323036</u>		
Mk. III XR-3 RS Turbo	1.85- 7.90		333802 <u>323024</u> 				333079 <u>323036</u>		
Mk. III 1.4, 1.6, XR-3	1.86- 7.90		333802 <u>323024</u> 				333079 <u>323036</u>		
<b>Escort, XR-3, RS (90- 95)</b>									
 1.1, 1.3 1.4, 1.4 i Exc. 1.4 IS 1.8 D	8.90- 1.95 8.90-10.90 8.90-11.90	633820	333820 <u>323024</u> 			441900	341900		

\*Excel-G is a new name of SUPER  
Excel-G ist der neue Name für SUPER  
Excel-G est le nom nouveau pour SUPER

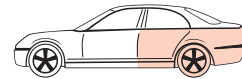
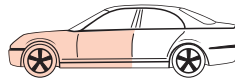

MODEL FAHRZEUG MODELE	YEAR JAHR ANNEE	FRONT/VORNE/AVANT				REAR/HINTEN/ARRIERE			
		PREMIUM Oil	EXCEL-G* Twin-tube Gas	GAS-A-JUST Mono-tube Gas		PREMIUM Oil	EXCEL-G* Twin-tube Gas	GAS-A-JUST Mono-tube Gas	
<b>Ford (Europe)</b>									
<b>Escort, XR-3, RS (90- 95)</b>									
 1.4, 1.4 i Exc.1.4 iS 1.6, 1.6 i, 1.8i Exc.1.6 iS, 1.8 iS, XR-3i 1.8 D, 1.8TD	10.90- 1.95 8.90- 1.95 11.90- 1.95	633821	333821			441900	341900		
		915206	SM1202		1,0				0,7
 1.4 iS, 1.6 iS, 1.8 iS 1.4 i, 1.6 i, 1.8 i Exc. XR-3i	8.90- 1.95		333821				341900		0,7
		915206	SM1202		1,0				0,7
 1.8 i RS 2000 16V Exc. Cosworth	92- 1.95 1.92- 1.95		333821						0,7
		915206	SM1202		1,0				0,7
 XR-3i RS 2000 16 V	1.92- 1.95 91- 1.95		333821						0,7
		915206	SM1202		1,0				0,7
RS Cosworth	4.92- 1.95		324015					243034	0,7
		915210							0,7
<b>Escort, XR-3, RS (95-)</b>									
 1.3, 1.4	1.95- 2.99		333826			441951	341951		0,4
		915206	SM1206		1,2		915211		0,4
 1.6, 1.8, 1.8D, 1.8 TD/TDi Exc. Si, XR-3i	1.95- 2.99		333826				341951		0,4
		915206	SM1206		1,2		915211		0,4
 1.6 Si, 1.8 Si, XR-3i	1.95- 2.99		333841						0,4
		915206	SM1206		1,2				0,4
 1.6 Si, 1.8 Si, XR-3i	1.95- 2.99		333826						0,4
		915206	SM1206		1,2				0,4
, RS 2000 Exc. Cosworth	1.95- 2.99		333841						0,4
		915206			1,2				0,4
<b>Escort Turnier (90-) </b>									
1.1, 1.3 1.4, 1.4i Exc 1.4 iS 1.8 D	8.90- 1.95 8.90-10.90 8.90-11.90	633820	333820				343257	553181	0,7
		915206	SM1202		1,0				0,7
1.4, 1.4i, 1.6, 1.6i, 1.8i Exc. 1.4 iS, 1.6 iS, 1.8 iS 1.8 D, 1.8 TD	10.90- 1.95 11.90- 1.95	633821	333821				343257	553181	0,7
		915206	SM1202		1,0				0,7
1.4 iS, 1.6 iS, 1.8 iS	10.90- 1.95		333821				343257	553181	0,7
		915206	SM1202		1,0				0,7
1.3, 1.4, 1.8 TD/TDi	1.95- 8.95		333826				343257	553181	0,7
		915206	SM1206		1,2		95 AB-18080-##		0,7



MODEL FAHRZEUG MODELE	YEAR JAHR ANNEE	FRONT/VORNE/AVANT			⚙️ ⌚	REAR/HINTEN/ARRIERE			⚙️ ⌚
		PREMIUM Oil	EXCEL-G* Twin-tube Gas	GAS-A-JUST Mono-tube Gas		PREMIUM Oil	EXCEL-G* Twin-tube Gas	GAS-A-JUST Mono-tube Gas	
<b>Ford (Europe)</b>									
<b>Escort Turnier (90-) 🚗</b>									
1.3, 1.4, 1.8 TD/TDi	8.95- 2.99		333826		⊕		343276	553201	⊕
		915206	SM1206		1,2		☐ = 95 AB-18080-##		⊕
2WD 1.6, 1.8, 1.8 D Incl. 1.6 Si, 1.8 Si	1.95- 8.95		333841		⊕		343257	553181	⊕
		915206	SM1206		1,2		☐ = 95 AB-18080-##		⊕
2WD 1.6, 1.8, 1.8 D Incl. 1.6 Si, 1.8 Si	8.95- 2.99		333841		⊕		343276	553201	⊕
		915206	SM1206		1,2		☐ = 95 AB-18080-##		⊕
<b>Fiesta, XR-2 🚗 (-96)</b>									
MK. I (GFBT) 1.0, 1.1, 1.3, 1.6 Exc. XR-2	76- 8.83	633009	333006		⊕	632802	332004		⊕
		915201			1,2				0,8
MK. I (GFBT) XR-2	81- 8.83		333044		⊕		332004		⊕
		915201			1,2				0,8
MK. II (FBD) 1.0, 1.1, 1.3, 1.4, 1.6, 1.6 Diesel Exc. XR-2	9.83-12.84	633803	333803		⊕	632802	332004		⊕
		915201	SM1203		1,2				0,8
MK. II (FBD) 1.0, 1.1, 1.3, 1.4, 1.6 Exc. XR-2, Diesel	1.85- 89	633803	333803		⊕	632802	332004		⊕
		915201	SM1200		1,2				0,8
MK. II (FBD) 1.6 Diesel	1.85- 89	633803	333803		⊕	632802	332004		⊕
		915201	SM1201		1,2				0,8
MK. II (FBD) XR-2	9.83-12.84		333076		⊕		332004		⊕
		915201	SM1203		1,2				0,8
MK. II (FBD) XR-2	1.85- 89		333803		⊕		332004		⊕
		915201	SM1200		1,2				0,8
MK. III (FAJ, FBJ, GFJ) 1.0, 1.1, 1.3, 1.4 Exc. S, iS, XR-2	1.89-12.89	633816 633817	333816 333817		⊕	441801	341801		⊕
		915205	SM1200		1,0				0,8
MK. III (FAJ, FBJ, GFJ) 1.8D	1.89-12.89	633816 633817	333816 333817		⊕	441801	341801		⊕
		915205	SM1201		1,0				0,8
MK. III (FAJ, FBJ, GFJ) 1.1 S/iS, 1.4 S/iS	1.89-12.89	633817	333817		⊕	441801	341801		⊕
		915205	SM1200		1,0				0,8
MK. III (FAJ, FBJ, GFJ) XR-2i	8.89-12.93		333819 333817		⊕		341801		⊕
			323819 323817		1,0		351801		⊕
		915206	SM1200						0,8

\*Excel-G is a new name of SUPER  
 Excel-G ist der neue Name für SUPER  
 Excel-G est le nom nouveau pour SUPER

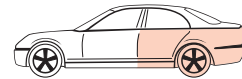
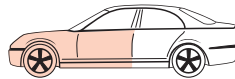

MODEL FAHRZEUG MODELE	YEAR JAHR ANNEE	FRONT/VORNE/AVANT				REAR/HINTEN/ARRIERE			
		PREMIUM Oil	EXCEL-G* Twin-tube Gas	GAS-A-JUST Mono-tube Gas		PREMIUM Oil	EXCEL-G* Twin-tube Gas	GAS-A-JUST Mono-tube Gas	
<b>Ford (Europe)</b>									
<b>Fiesta, XR-2  (-96)</b>									
MK. III (FAJ, FBJ, GFJ) 1.0, 1.1, 1.3, 1.4 Exc. S, iS, XR-2	1.90-12.93	633818	333818 <u>323818</u>			441801	341801 <u>351801</u>		
			915205  SM1200		1,0				⊖ ⊖ 0,8
MK. III (FAJ, FBJ, GFJ) 1.8D	1.90-12.93	633818	333818 <u>323818</u>			441801	341801 <u>351801</u>		
			915205  SM1201		1,0				⊖ ⊖ 0,8
MK. III (FAJ, FBJ, GFJ) 1.1S/iS, 1.4 S/iS	1.90-12.93	633819▼ 633817	333819▼ 333817 <u>323819▼</u> <u>323817</u>			441801	341801 <u>351801</u>		
			915205  SM1200		1,0				⊖ ⊖ 0,8
1.1, 1.3, 1.4 (FAJ, FBJ, GFJ) ⊖	1.94- 96	633822	333822				341802		
			915206  SM1200		1,0				⊖ ⊖ 0,8
1.8D (FAJ, FBJ, GFJ) ⊖	1.94- 96	633822	333822				341802		
			915206  SM1201		1,0				⊖ ⊖ 0,8
1.1, 1.3, 1.4, 1.6 (FAJ, FBJ, GFJ) ⊕	1.94- 96		333823				341802		
			915206  SM1200		1,0				⊖ ⊖ 0,8
<b>Fiesta  (96-)</b>									
1.0, 1.25, 1.3, 1.4 ⊖ ⊕	(JA, JB) 8.95-10.98		333701				341952		
			915206  SM1204						⊥ ⊗
1.0, 1.25, 1.3, 1.4 ⊖ ⊕	(JA, JB) 11.98-		333701				341953		
			915206  SM1204						⊥ ⊖
1.0, 1.25, 1.3, 1.4 ⊕ ⊕	(JA, JB) 8.95-10.98		333702				341952		
			915206  SM1204						⊥ ⊗
1.0, 1.25, 1.3, 1.4 ⊕ ⊕	(JA, JB) 11.98-		333702				341953		
			915206  SM1204						⊥ ⊖
1.8D ⊖ ⊕	(JA, JB) 8.95-10.98		333703				341952		
			915206  SM1204						⊥ ⊗
1.8D ⊖ ⊕	(JA, JB) 11.98-		333703				341953		
			915206  SM1204						⊥ ⊖
1.8D ⊕ ⊕	(JA, JB) 8.95-10.98		333704				341952		
			915206  SM1204						⊥ ⊗



MODEL FAHRZEUG MODELE	YEAR JAHR ANNEE	FRONT/VORNE/AVANT			⚙️ ⌚	REAR/HINTEN/ARRIERE			⚙️ ⌚	
		PREMIUM Oil	EXCEL-G* Twin-tube Gas	GAS-A-JUST Mono-tube Gas		PREMIUM Oil	EXCEL-G* Twin-tube Gas	GAS-A-JUST Mono-tube Gas		
<b>Ford (Europe)</b>										
<b>Fiesta 🚗 (96-)</b>										
1.8D ⊕ ⊕	(JA, JB)	11.98-		333704 915206 🛞 SM1204	⊕⊕		341953		⊥ ⊖	
<b>Focus 🚗, 🚗</b>										
1.4, 1.6, 1.8, 2.0, 1.8 TD		98-		333710 L 333709 R <u>323057 L</u> <u>323056 R</u> 915208	⊕⊕		343290 <u>353022</u>		⊥ ⊖	
<b>Focus 🚗</b>										
1.4, 1.6, 1.8, 2.0, 1.8 TD		98-		333710 L 333709 R <u>323057 L</u> <u>323056 R</u> 915208	⊕⊕		343291 <u>353023</u>		⊖ ⊖	
<b>Galaxy</b>										
2WD, 4WD, ALL Exc. 🚗		5.95-		334947 🛞 SM1704	⊕⊕		343319	553244	⊖ ⊖	
<b>Granada (GU/GNU) 🚗, 🚗</b>										
1.6, 1.7, 2.0, 2.3, 2.6, 3.0		71- 8.77	443018	343003	553008	⊖ ⊖ 0,7	443019	343004	554007	⊥ ⊖ 0,7
1.6, 1.7, 2.0, 2.3, 2.6, 2.8, 1.9D, 2.1D, 2.5D		9.77- 4.85		343003	553008	⊖ ⊖ 0,7		343004	554007	⊥ ⊖ 0,7
<b>Ka 🚗</b>										
1.0, 1.3 ALL		9.96-10.98		333700 915206 🛞 SM1204	⊕⊕		341952		⊥ ⊗	
1.0, 1.3 ALL		10.98- 3.00		333700 915206 🛞 SM1204	⊕⊕		341953		⊥ ⊖	
1.0, 1.3 ALL Incl. Street Version		4.00-		333700 915206 🛞 SM1204	⊕⊕		341817		⊥ ⊖	
<b>Maverick</b>										
ALL	(R20)	93- 4.96	444102	344200	554070	⊥ ⊖	443295		553230	○ ○

Ford

\*Excel-G is a new name of SUPER  
 Excel-G ist der neue Name für SUPER  
 Excel-G est le nom nouveau pour SUPER



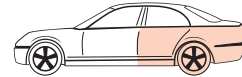
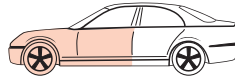

MODEL FAHRZEUG MODELE	YEAR JAHR ANNEE	FRONT/VORNE/AVANT				REAR/HINTEN/ARRIERE			
		PREMIUM Oil	EXCEL-G* Twin-tube Gas	GAS-A-JUST Mono-tube Gas		PREMIUM Oil	EXCEL-G* Twin-tube Gas	GAS-A-JUST Mono-tube Gas	
<b>Ford (Europe)</b>									
<b>Maverick</b>									
(UDS/UNS)	9.96- 4.98	444102	344200	554070	$\perp$ $\ominus$	443295		553230	$\circ$ $\circ$
(1EZ)	12.00-		◇ 334334 L 334333 R ◇		$\oplus$		344356		$\perp$ $\ominus$
<b>Mondeo (Exc.  )</b>									
 1.6, 1.8, 2.0, 2.5, 1.8 TD Exc. Sport sus.	1.93- 9.94		334905		$\oplus$		334906		$\oplus$
				SM1205	1,3				0,7
$\oplus$ Sport sus. 2.0, 2.5	6.93- 9.94		334905		$\oplus$		334906		$\oplus$
				SM1205	1,3				0,7
 1.6, 1.8, 2.0, 2.5, 1.8 TD Incl. Sport sus.	10.94- 7.96		334905		$\oplus$		334907 ▼ 334906		$\oplus$
				SM1205	1,3				0,7
 1.8, 2.0, 1.8 TD	1.93- 7.96		334905		$\oplus$				$\oplus$
				SM1205	1,3				0,7
MONDEO II (BAP, BFP)  1.6, 1.8, 2.0, 2.5, 1.8 TD Exc. Sport sus.	8.96-11.00		334921		$\oplus$		334922		$\oplus$
				SM1205	1,3				0,7
MONDEO III (B5Y, B4Y) 1.8-16V 2.0-16V 2.5 V6-24V 2.0TD	11.00-		335922		$\oplus$		335923		$\oplus$
<b>Mondeo </b>									
, 1.6, 1.8, 2.0, 2.5, 1.8 TD	1.93- 7.96		334905		$\oplus$			554078 Exc.	$\ominus$ $\ominus$ 0,7
				SM1205	1,3				
MONDEO II (BNP)  1.6, 1.8, 2.0, 2.5, 1.8 TD Exc. Sport sus.	8.96-11.00		334921		$\oplus$			553217 Exc.	$\ominus$ $\ominus$ 0,7
				SM1205	1,3				
MONDEO III (BWY) 1.8-16V 2.0-16V 2.5 V6-24V 2.0TD	11.00-		335922		$\oplus$			553217 Exc.	$\ominus$ $\ominus$
<b>Orion</b>									
1.3, 1.4, 1.6 Exc. 1.6 i 1.6 Diesel	5.83-12.84 5.83-12.84	633802	333802		$\oplus$	632801	332801		$\oplus$
			323024		1,0		323036		0,9
				SM1203					





MODEL FAHRZEUG MODELE	YEAR JAHR ANNEE	FRONT/VORNE/AVANT				REAR/HINTEN/ARRIERE			
		PREMIUM Oil	EXCEL-G* Twin-tube Gas	GAS-A-JUST Mono-tube Gas		PREMIUM Oil	EXCEL-G* Twin-tube Gas	GAS-A-JUST Mono-tube Gas	
<b>Ford (Europe)</b>									
<b>Orion</b>									
1.3, 1.4, 1.6 Exc. 1.6 i	1.85- 7.90	633802	333802 <u>323024</u> 915201  SM1200			632801	332801 <u>323036</u> 915204		
1.6 Diesel	1.85-12.85	633802	333802 <u>323024</u> 915201  SM1201			632801	332801 <u>323036</u> 915204		
1.6 Diesel , 1.8 Diesel Exc. Ghia (Portugal)	1.86- 7.90	633834	333834 <u>323024</u> 915201  SM1201			632801	332801 <u>323036</u> 915204		
1.6 i	5.83-12.84		333802 <u>323024</u> 915201  SM1203				333079 <u>323036</u>		
1.6 i	1.85- 7.90		333802 <u>323024</u> 915201  SM1200				333079 <u>323036</u>		
1.6 Diesel Ghia (Portugal)	1.86- 7.90		333802 <u>323024</u> 915201  SM1201				333079 <u>323036</u>		
1.1,1.3 1.4, 1.4 i, 1.8 Diesel Exc. S, Giha	8.90- 1.95 8.90-10.90	633820	333820 <u>323024</u> 915206  SM1202			441900	341900		
1.4, 1.4 i, 1.8 Diesel 1.6, 1.6 i, 1.8 i Exc. S, Giha	11.90- 1.95 8.90-10.90	633821	333821 <u>323024</u> 915206  SM1202			441900	341900		
1.4 iS, 1.6 iS, 1.8 iS Ghia	8.90- 1.95		333821 <u>323024</u> 915206  SM1202				341900		
<b>Puma </b>									
1.4-16V	11.97-10.00		333943				341916		
1.7-16V	3.97-		333943				341916		
<b>Scorpio</b>									
(GFR) 2.0, 2.3, 2.9-V6, 2.5TD Incl. 16V, 24 V	10.94- 8.98		335905 L 335904 R <u>323024</u> 915206  SM1202				343205 553151 Exc.		

\*Excel-G is a new name of SUPER  
Excel-G ist der neue Name für SUPER  
Excel-G est le nom nouveau pour SUPER

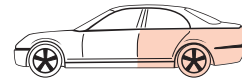
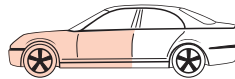

MODEL FAHRZEUG MODELE	YEAR JAHR ANNEE	FRONT/VORNE/AVANT				REAR/HINTEN/ARRIERE			
		PREMIUM Oil	EXCEL-G* Twin-tube Gas	GAS-A-JUST Mono-tube Gas		PREMIUM Oil	EXCEL-G* Twin-tube Gas	GAS-A-JUST Mono-tube Gas	
<b>Ford (Europe)</b>									
<b>Scorpio</b>									
(GNR) 2.0, 2.3, 2.9-V6, 2.5TD Incl. 1.6 V, 2.4 V	10.94- 8.98		335905 L 335904 R				OE =		
<b>Scorpio/Granada (GAE/GGE)</b>									
(GAE) 1.8, 2.0, 2.0 i, 2.4 i, 2.8 i, 2.9 i, 2.5 D, 2.5 TD Exc. , 2.9i-24V	5.85- 1.92	634015	334018 				343205 Exc.	553151	
(GAE) 2.0, 2.4, 2.9, 2.9-24V, 2.5TD	2.92- 9.94		334018 				343205 Exc.	553151	
(GGE) 2.0, 2.4, 2.9, 2.9-24V, 2.5TD	2.92- 9.94		334018 				OE =		
<b>Sierra, XR-4, Cosworth  </b>									
1.3, 1.6, 2.0, 2.3, 2.3 D	12.82- 5.84	633038	333019 			441048	341044	551035	
XR-4i	12.82- 5.84		333019 				341044	551035	
 1.3, 1.6, 1.8, 2.0, 2.3	6.84- 93	633832	333832 <u>323037</u> 			441048	341044	551035 <u>241007</u>	
 2.3D	6.84- 93	633832	333832 <u>323037</u> 			441048	341044	551035 <u>241007</u>	
 XR-4i Exc. Cosworth 2.8i, 2.9i	6.84- 93		333832 <u>323037</u> 				341044	551035 <u>241007</u>	
 Cosworth	86- 90							553226 <u>243034</u>	
<b>Sierra  </b>									
 Exc. Cosworth	85- 93		334219 <u>324015</u> 					553226 <u>243034</u>	



MODEL FAHRZEUG MODELE	YEAR JAHR ANNEE	FRONT/VORNE/AVANT				REAR/HINTEN/ARRIERE			
		PREMIUM Oil	EXCEL-G* Twin-tube Gas	GAS-A-JUST Mono-tube Gas		PREMIUM Oil	EXCEL-G* Twin-tube Gas	GAS-A-JUST Mono-tube Gas	
<b>Ford (Europe)</b>									
<b>Sierra</b>									
 Cosworth	90- 93		334219 324015 		 0,7			553226 243034	 0,6
<b>Sierra</b>									
 1.3, 1.6, 2.0, 2.3, 2.3D	12.82- 5.84	633038	333019 		 0,7	443208	343187 Exc.	553125	 0,8
 1.3, 1.6, 2.0, 2.3	6.84- 93	633832	333832 		 0,7	443208	343187 Exc.	553125	 0,8
 2.3 D	6.84- 93	633832	333832 		 0,7	443208	343187 Exc.	553125	 0,8
 	85- 93		334219 		 0,7	443208	343187 Exc.	553125	 0,8
<b>Taurus</b>									
17 M, 20 M (P5) 17 M, 20 M (P7) 26M	8.64- 66 67- 70 69- 70	665002	365047			443015	343077	553136	
1.3, 1.6, 2.0, 2.3	70-11.82	443016	343001	553007	 0,7	443017	343002	554006	 0,6
<b>Ford Commercial (Europe)</b>									
<b>Escort Van, Express</b>									
20, 40, 50	1.75- 7.80	663004	363004			443109			
35, 55 Exc.	80- 5.83	633099				443247	343228		
35, 55 Exc.	6.83- 7.90	633100	333074 			443247	343228		
 	8.90- 95	633820	333820 		 1,0	443278			
 	8.90- 95	633821	333821 		 1,0	443278			

\*Excel-G is a new name of SUPER  
Excel-G ist der neue Name für SUPER  
Excel-G est le nom nouveau pour SUPER

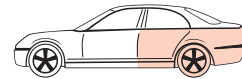
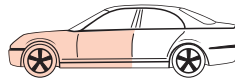

MODEL FAHRZEUG MODELE	YEAR JAHR ANNEE	FRONT/VORNE/AVANT				REAR/HINTEN/ARRIERE			
		PREMIUM Oil	EXCEL-G* Twin-tube Gas	GAS-A-JUST Mono-tube Gas		PREMIUM Oil	EXCEL-G* Twin-tube Gas	GAS-A-JUST Mono-tube Gas	
<b>Ford Commercial (Europe)</b>									
<b>Escort Van, Express </b>									
	1.95-		333826		+	443278			⊖
<b>Fiesta Van, Courier </b>									
Van 7 cwt 1.3	76- 8.83	633009	333006		+	632802	332004		+
Van 7 cwt 1.3, 1.6 Diesel	9.83-12.84	633803	333803		+	632802	332004		+
Van 7 cwt 1.3	1.85- 89	633803	333803		+	632802	332004		+
Van 7 cwt 1.6 Diesel	1.85- 89	633803	333803		+	632802	332004		+
Van Exc. Diesel, Courier (FVJ)	89-12.93	633818	333818		+	441801	341801		⊖
									⊖
Van Diesel Exc. Courier (FVJ)	89-12.93	633818	333818		+	441801	341801		⊖
									⊖
Courier 1.3 (F3, F5)	89-12.93	633819▼ 633817	333819▼ 333817		+		343273		⊖
					1,0				⊖
Courier 1.8 Diesel (F3, F5)	89-12.93	633819▼ 633817	333819▼ 333817		+		343273		⊖
					1,0				⊖
Courier 1.3 (F3, F5)	94- 96		333823		+		343273		⊖
					1,0				⊖
Courier 1.8 Diesel (F3, F5)	94- 96		333823		+		343273		⊖
					1,0				⊖
1.0, 1.25, 1.3, 1.4 ⊖ ⊕ (JV)	8.95-10.98		333701		+		341952		⊥
									⊗
1.0, 1.25, 1.3, 1.4 ⊖ ⊕ (JV)	11.98-		333701		+		341953		⊥
									⊖
1.0, 1.25, 1.3, 1.4 ⊕ ⊕ (JV)	8.95-10.98		333702		+		341952		⊥
									⊗



MODEL FAHRZEUG MODELE	YEAR JAHR ANNEE	FRONT/VORNE/AVANT				REAR/HINTEN/ARRIERE			
		PREMIUM Oil	EXCEL-G* Twin-tube Gas	GAS-A-JUST Mono-tube Gas		PREMIUM Oil	EXCEL-G* Twin-tube Gas	GAS-A-JUST Mono-tube Gas	
<b>Ford Commercial (Europe)</b>									
<b>Fiesta Van, Courier </b>									
1.0, 1.25, 1.3, 1.4 	(JV)	11.98-		333702 			341953		
1.8D 	(JV)	8.95-10.98		333703 			341952		
1.8D 	(JV)	11.98-		333703 			341953		
1.8D 	(JV)	8.95-10.98		333704 			341952		
1.8D 	(JV)	11.98-		333704 			341953		
Courier 1.3, 1.4 	(J3, J5)	96-		333701 			343273		
Courier 1.3, 1.4 	(J3, J5)	96-		333702 			343273		
Courier 1.8 D 	(J3, J5)	96-		333703 			343273		
Courier 1.8 D 	(J3, J5)	96-		333704 			343273		
<b>Sierra </b>									
PE 45		88-	633194				444134		
<b>TRANSIT  = 2.69m (106")</b>									
, 75, 100		9.70- 77	444029	344032	554048		444030	344033	
, 75, 100, 125		9.70- 77	444029	344032	554048		444030	344033	554049
 80, 100, 120		78-10.85	444029	344032	554048		444030	344033	
100 ,  100, 125		78-10.85 78-10.85	444029	344032	554048		444030	344033	554049

\*Excel-G is a new name of SUPER  
 Excel-G ist der neue Name für SUPER  
 Excel-G est le nom nouveau pour SUPER

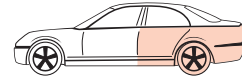
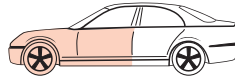

MODEL FAHRZEUG MODELE	YEAR JAHR ANNEE	FRONT/VORNE/AVANT			 ⊕ ⊖ 0,6	REAR/HINTEN/ARRIERE			 ⊕ ⊖ 0,6
		PREMIUM Oil	EXCEL-G* Twin-tube Gas	GAS-A-JUST Mono-tube Gas		PREMIUM Oil	EXCEL-G* Twin-tube Gas	GAS-A-JUST Mono-tube Gas	
<b>Ford Commercial (Europe)</b>									
<b>TRANSIT  = 3.02m (118")</b>									
 125, 130, 150, 160, 175	9.70- 77	444029	344032	554048	⊕ ⊖ 0,6	444030	344033	554049	⊕ ⊖ 0,6
 100 L, 130, 160, 190	78-10.85	444029	344032	554048	⊕ ⊖ 0,6	444030	344033	554049	⊕ ⊖ 0,6
 	78-10.85	444029	344032	554048	⊕ ⊖ 0,6	444030	344033		⊕ ⊖ 0,6
<b>TRANSIT  = 2.82m</b>									
80, 100, 115, 120 	11.85- 9.91	635001	335001		⊕ 0,8	444094		554064	⊕ ⊖ 0,6
<b>TRANSIT  = 3.02 m, 3.47 m</b>									
100 L, 130, 160, 190 	11.85- 9.91	443243		553164	⊖ ⊕ 0,6	444094		554064	⊕ ⊖ 0,6
<b>TRANSIT  = 2.835 m</b>									
100, 115 80, 120	9.91- 7.94 8.91- 7.95	635800	335800		⊕ 0,8	444124		554083	⊕ ⊖ 0,6
80, 120	8.95- 00	635800	335800 		⊕ 0,8	444124		554083	⊕ ⊖ 0,6
150 S	9.91- 7.95	635800	335800		⊕ 0,8	444124		554084	⊕ ⊖ 0,6
150 S	8.95- 00	635800	335800 		⊕ 0,8	444124		554084	⊕ ⊖ 0,6
<b>TRANSIT  = 3.570m</b>									
130	9.91- 7.95	635800	335800		⊕ 0,8	444125		554085	⊕ ⊖ 0,6
130	8.95- 00	635800	335800 		⊕ 0,8	444125		554085	⊕ ⊖ 0,6
190 190EF	9.91- 7.95 8.94- 7.95	635800	335800		⊕ 0,8	444124		554083	⊕ ⊖ 0,6
190 190 EF	8.95- 00	635800	335800 		⊕ 0,8	444124		554083	⊕ ⊖ 0,6



MODEL FAHRZEUG MODELE	YEAR JAHR ANNEE	FRONT/VORNE/AVANT				REAR/HINTEN/ARRIERE			
		PREMIUM Oil	EXCEL-G* Twin-tube Gas	GAS-A-JUST Mono-tube Gas		PREMIUM Oil	EXCEL-G* Twin-tube Gas	GAS-A-JUST Mono-tube Gas	
<b>Ford Commercial (Europe)</b>									
<b>TRANSIT</b> = 3.570m									
100L, 150L, 190L	9.91- 7.95	635800	335800			444124		554084	
					0,8				0,6
100L, 150L, 190L	8.95- 00	635800	335800			444124		554083	
				SM1208	0,8				0,6
<b>TRANSIT</b>									
FT230 FT280 FT300 = 3.300m & 3.750m Exc.	3.00-						343393		
FT330 FT350 = 2.933m - 3.137m Exc.	3.00-						343391		
FT330 FT350 = 3.300m & 3.750m Exc.	3.00-						343392		
<b>Ford-Mercury (US)</b>									
<b>Aerostar Mini Van</b>									
	89- 97		344083				344290		
	90- 97		344289				344290		
<b>Explorer</b>									
	91-10.94		344268	555014			344269	555015	
	11.94-		341302	551090			344269	555015	
<b>Probe</b>									
2.2 Turbo	90- 92		OE =				OE =		
2.0 - 16V 2.5 - 24V	93-		334216 L 334215 R				334217		

\*Excel-G is a new name of SUPER  
 Excel-G ist der neue Name für SUPER  
 Excel-G est le nom nouveau pour SUPER

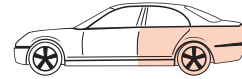
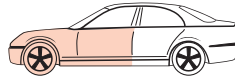

MODEL FAHRZEUG MODELE	YEAR JAHR ANNEE	FRONT/VORNE/AVANT				REAR/HINTEN/ARRIERE			
		PREMIUM Oil	EXCEL-G* Twin-tube Gas	GAS-A-JUST Mono-tube Gas		PREMIUM Oil	EXCEL-G* Twin-tube Gas	GAS-A-JUST Mono-tube Gas	
<b>Ford-Mercury (US)</b>									
<b>Taurus, Sable</b>									
 ALL	86- 95		334221		+		235011 ▼ 334325		+
 ALL	86- 95		334221		+		344271		⊥ ⊕
<b>Windstar Mini Van</b>									
ALL	95-		235609		+		344291 Exc.		⊕ ⊕
<b>Freight Rover (GB) ⇒ Austin-Rover Group (GB)</b>									
<b>GAZ (RUS)</b>									
Volga 3102, 31029, 31022	82- 94		344014		⊥ ⊕		344275		⊥ ⊕
<b>General Motors - Buick - Chevrolet - GMC Truck - Pontiac (US)</b>									
<b>Astro, Safari Mini Van</b>									
, ALL	85- 90		344081		⊥ ⊕		344082		⊕ ⊕
 ALL	91-		344081		⊥ ⊕		344082		⊕ ⊕
 ALL	91-		344266		⊕ ⊕		344082		⊕ ⊕
<b>Century, Special, Celebrity</b>									
ALL	84- 96		234019		+		343160		⊥ ⊕
<b>Lumina APV Mini Van, Trans Sport Mini Van</b>									
ALL	84- 96		234019		+		343160 Exc.		⊥ ⊕
<b>S-Series - Blazer, Jimmy, Sonoma</b>									
 ALL	82-		344040		⊥ ⊕		344041		⊕ ⊕





MODEL FAHRZEUG MODELE	YEAR JAHR ANNEE	FRONT/VORNE/AVANT				REAR/HINTEN/ARRIERE			
		PREMIUM Oil	EXCEL-G* Twin-tube Gas	GAS-A-JUST Mono-tube Gas		PREMIUM Oil	EXCEL-G* Twin-tube Gas	GAS-A-JUST Mono-tube Gas	
<b>General Motors - Buick - Chevrolet - GMC Truck - Pontiac (US)</b>									
<b>S-Series - Blazer, Jimmy, Sonoma</b>									
 Exc. ZR2 Wide Stance Package Exc. ZR2 High Rider Package	82-		344042				344041		
<b>GMC Truck (US) ⇒ General Motors (US)</b>									
<b>Hillman (GB) ⇒ Talbot (F) (GB)</b>									
<b>Honda (J)</b>									
<b>Accord /Vigor    (Aerodeck)</b>									
(SV 100, SM 100/120/200) 	9.78- 9.81	633031 L 633030 R				633033 L 633032 R			
(SY 100/110, SZ 100/120) 1600, 1800 Exc.  (  )	10.81-6.83	633052 L 633051 R				631001	331001		
(AC 100, AD 100) 1600, 1800 Exc.  (  ), ABS	7.83- 5.85	633054 L 633053 R	333033 L 333032 R			631001	331001		
(CA 4, CA 5) 1600, 2000, 2000 i, 2000 i-16 V	5.85- 9.89	441062 L 441061 R	341073 L 341072 R			441063	341074		
(CB1, CB3) 1.8, 2.0, 2.0i, 2.0i-16V	89- 93		341172 L 341171 R				341173		
(CB7) 2.2	90- 93		341172 L 341171 R						
 2.0 (CC9), 2.2 (CB8, CB9)	91- 93		341172 L 341171 R				341176		
 1.8, 2.0, 2.3 (CC7)	93- 96		341172 L 341171 R				341173		
 1.8 (CE7), 2.0 (CE8), 2.2 VTEC (CE9) 2.0 Turbo Diesel (CF1)	96-10.98		341172 L 341171 R				341173		
 2.0 (CC1)	92- 96		341172 L 341171 R				341173		

\*Excel-G is a new name of SUPER  
Excel-G ist der neue Name für SUPER  
Excel-G est le nom nouveau pour SUPER

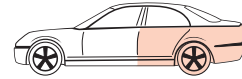
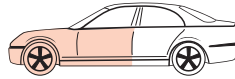

MODEL FAHRZEUG MODELE	YEAR JAHR ANNEE	FRONT/VORNE/AVANT				REAR/HINTEN/ARRIERE			
		PREMIUM Oil	EXCEL-G* Twin-tube Gas	GAS-A-JUST Mono-tube Gas		PREMIUM Oil	EXCEL-G* Twin-tube Gas	GAS-A-JUST Mono-tube Gas	
<b>Honda (J)</b>									
<b>Accord /Vigor  (Aerodeck)</b>									
 2.0 (CD9), 2.2 (CD7)	94- 2.98		341175 L 341174 R		$\frac{\perp}{\otimes}$		341176		$\frac{\perp}{\otimes}$
 2.0 (CE2), 2.2 (CE1)	94-		341175 L 341174 R		$\frac{\perp}{\otimes}$		341176		$\frac{\perp}{\otimes}$
 1.6 (CG7), 1.8 (CG8), 2.0 (CG9)	10.98-		341255		$\frac{\perp}{\otimes}$		341256		$\frac{\perp}{\oplus}$
 2.2 Type-R (CH1)	10.98-		341255		$\frac{\perp}{\otimes}$		341256		$\frac{\perp}{\oplus}$
 2.0 16V (CG4)	2.98- 99		341257		$\frac{\perp}{\otimes}$		341258		$\frac{\perp}{\oplus}$
 2.0 16V (CG4)	99-		341257		$\frac{\perp}{\otimes}$		341258		$\frac{\perp}{\oplus}$
 3.0-V6 24V (CG2)	2.98- 99		341257		$\frac{\perp}{\otimes}$		341258		$\frac{\perp}{\oplus}$
 3.0-V6 24V (CG2)	99-		341257		$\frac{\perp}{\otimes}$		341258		$\frac{\perp}{\oplus}$
<b>Acty</b>									
 Exc.  (4WD)						442023			$\frac{\perp}{\oplus}$
<b>Civic , Ballade </b>									
 Exc.  = CVCC	75- 79	632019 L 632018 R	332031 L 332030 R		$\frac{\oplus}{\oplus}$ 1,4	632022 L 632021 R	332033 L 332032 R		$\frac{\oplus}{\oplus}$ 1,6
 Exc.  = CVCC	80- 83	633034	333021		$\frac{\oplus}{\oplus}$ 2,0	633036 L 633035 R	333023 L 333022 R		$\frac{\oplus}{\oplus}$ 2,2
 = CVCC	75- 77	632019 L 632018 R	332031 L 332030 R		$\frac{\oplus}{\oplus}$	632022 L 632021 R	332033 L 332032 R		$\frac{\oplus}{\oplus}$
 = CVCC	78- 83	632019 L 632018 R	332031 L 332030 R		$\frac{\oplus}{\oplus}$	632023	332040		$\frac{\oplus}{\oplus}$
1200 (AL, AM), 1300 (AG, AJ) 1500 (AH, AK)	84- 87	633056 L 633055 R	333031 L 333030 R		$\frac{\oplus}{\oplus}$ 2,2	441054	341050		$\frac{\perp}{\oplus}$ 2,0



MODEL FAHRZEUG MODELE	YEAR JAHR ANNEE	FRONT/VORNE/AVANT				REAR/HINTEN/ARRIERE			
		PREMIUM Oil	EXCEL-G* Twin-tube Gas	GAS-A-JUST Mono-tube Gas		PREMIUM Oil	EXCEL-G* Twin-tube Gas	GAS-A-JUST Mono-tube Gas	
<b>Honda (J)</b>									
<b>Civic , Ballade</b>									
1300 (EC 8), 1400 (EC 9, ED 2) 1600 PGM-F1 (ED 7, ED 4) S000001 → S100001	1.88-12.88		341086 L 341085 R		$\perp$ $\otimes$ 2,2		341093		$\perp$ $\otimes$ 2,0
1300 (EC 8) 1400 (EC 9, ED 2) 1500 PGM-F1 (ED 6, ED 3) 1600 PGM-F1 (ED 7, ED 4) 1600 VTEC (EE 9) S100001 →	1.89-12.91 1.89-12.89 1.89-12.91 1.89-12.91 1.90-12.91		341088 L 341087 R  <u>351009 L</u> <u>351008 R</u>		$\perp$ $\otimes$ 2,2		341094  <u>351010</u>		$\perp$ $\otimes$ 2,0
1.3 (EG3), 1.5 (EG4, EG8) 1.6 VTEC (EG5, EH9) 1.6 VTEC VTi (EG6, EG9)	91- 95		341139 L 341138 R  <u>351012 L</u> <u>351011 R</u>		$\perp$ $\otimes$ 3,2		341094  <u>351010</u>		$\perp$ $\otimes$ 2,4
 1.4 (EJ9), 1.5 (EK3), 1.6 (EK1, EK 4) Incl. VTEC	95- 01		341203		$\perp$ $\otimes$		341198		$\perp$ $\otimes$
 1.4 (MA8, MB2), 1.5 (MA9, MB3) 1.6 (MB1, MB4), 1.8 (MB6) 2.0 Turbo Diesel (MB7) Incl. VTEC	95- 01		341234 L 341233 R		$\perp$ $\otimes$		341131		$\perp$ $\otimes$
Aerodeck 1.4 (MB8), 1.5 (MB9) 1.6 (MC1), 1.8 (MC2) 2.0 Turbo Diesel (MC3) Incl. VTEC	98- 01		341234 L 341233 R		$\perp$ $\otimes$		341131		$\perp$ $\otimes$
<b>Civic CR-X/Ballade CR-X</b> (  :  JHM ... )									
1500 (AF)	84- 87	633056 L 633055 R	333031 L 333030 R		$\oplus$  2,2	441054	341050		$\perp$ $\otimes$ 2,0
1600 Si (AS)	86- 87	633093 L 633092 R			$\oplus$	441054	341050		$\perp$ $\otimes$ 2,0
1600 PGM-F1 (ED 9) S000001 → S100001	1.88-12.88		341086 L 341085 R		$\perp$ $\otimes$ 2,2		341093		$\perp$ $\otimes$ 2,0
1600 PGM-F1 (ED 9) 1600 VTEC (EE 8) S100001 →	1.89- 3.92 1.90- 3.92		341088 L 341087 R  <u>351009 L</u> <u>351008 R</u>		$\perp$ $\otimes$ 2,2		341094  <u>351010</u>		$\perp$ $\otimes$ 2,0
1.6 VTEC (EH6) 1.6 VTEC VTi (EG2)	4.92- 98		341139 L 341138 R  <u>351012 L</u> <u>351011 R</u>		$\perp$ $\otimes$ 3,4		341094  <u>351010</u>		$\perp$ $\otimes$ 2,6

\*Excel-G is a new name of SUPER  
Excel-G ist der neue Name für SUPER  
Excel-G est le nom nouveau pour SUPER



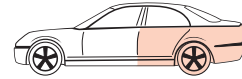
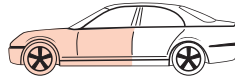

MODEL FAHRZEUG MODELE	YEAR JAHR ANNEE	FRONT/VORNE/AVANT				REAR/HINTEN/ARRIERE			
		PREMIUM Oil	EXCEL-G* Twin-tube Gas	GAS-A-JUST Mono-tube Gas		PREMIUM Oil	EXCEL-G* Twin-tube Gas	GAS-A-JUST Mono-tube Gas	
<b>Honda (J)</b>									
<b>Civic Coupé/Ballade Coupé</b> (  :  1HG ... )									
1.5 (EJ2) 1.6 VTEC (EJ1)	94- 95		341139 L 341138 R  351012 L 351011 R		$\frac{1}{\otimes}$ 3,2		341094  351010		$\frac{1}{\otimes}$ 2,4
1.6 (EJ6) 1.6 VTEC (EJ7, EJ8, EM1)	95- 01		341203		$\frac{1}{\otimes}$		341198		$\frac{1}{\otimes}$
<b>Civic</b> ,									
(EM2)	01-		$\diamond$ 331009 L 331008 R $\diamond$		$\oplus$		341311		$\frac{1}{\otimes}$
(EP1,EP2,EP4) Exc, Type-R	01-		$\diamond$ 331009 L 331008 R $\diamond$		$\oplus$		341311		$\frac{1}{\otimes}$
2.0 Type-R 	(EP3) 01-		$\diamond$ 331011 L 331010 R $\diamond$		$\oplus$		341311		$\frac{1}{\otimes}$
(EU7,EU8,EU9)	01-		$\diamond$ 331009 L 331008 R $\diamond$		$\oplus$		341311		$\frac{1}{\otimes}$
<b>Civic Shuttle/Ballade Shuttle</b>									
1500 (AN)	84- 87	633091 L 633090 R			$\oplus$		341077		$\frac{1}{\otimes}$ 2,0
1500 (AR)	85- 87	633094			$\oplus$		341078		$\frac{1}{\otimes}$
1400 (EE 1), 1500 (EE 2), 1600 (EE 4) S000001 → S100001	1.88-12.88		341090 L 341089 R		$\frac{1}{\otimes}$ 2,2		341095		$\frac{1}{\otimes}$ 2,0
1400 (EE 1), 1500 (EE 2), 1600 (EE 4) S100001 → S200001	1.89-12.89		341092 L 341091 R		$\frac{1}{\otimes}$ 2,2		341096		$\frac{1}{\otimes}$ 2,0
1400 (EE 1), 1500 (EE 2), 1600 (EE 4) S200001 →	1.90- 95		341092 L 341091 R		$\frac{1}{\otimes}$ 2,2		341095		$\frac{1}{\otimes}$ 2,0
<b>Concerto</b>									
1.4, 1.5i, 1.6, 1.6i 1.6-16 V, 1.6i-16 V	(HW) 90- 96		334069 L 334068 R		$\oplus$ 2,6		341131		$\frac{1}{\otimes}$ 3,0
<b>CR-V</b>									
2.0 16V	(RD) 10.95- 1.99		341260		$\frac{1}{\otimes}$		341261		$\frac{1}{\otimes}$



MODEL FAHRZEUG MODELE	YEAR JAHR ANNEE	FRONT/VORNE/AVANT				REAR/HINTEN/ARRIERE			
		PREMIUM Oil	EXCEL-G* Twin-tube Gas	GAS-A-JUST Mono-tube Gas		PREMIUM Oil	EXCEL-G* Twin-tube Gas	GAS-A-JUST Mono-tube Gas	
<b>Honda (J)</b>									
<b>CR-V</b>									
2.0 16V	(RD)	1.99-		341260				341261	
<b>HR-V</b>									
1.6 16V	(GH)	3.99- 00		334244 L <sup>1)</sup> 334243 R <sup>1)</sup>				343315 <sup>3)</sup>	
1.6 16V	(GH)	00-		334244 L <sup>2)</sup> 334243 R <sup>2)</sup>				343316 <sup>4)</sup>	
1.6 16V	(GH)	3.99- 00		334244 L 334243 R				343315 <sup>5)</sup>	
1.6 16V	(GH)	00-		334244 L 334243 R				343316 <sup>6)</sup>	
1) 334243 (RH): O.E.=51605-S2H-G02, 334244 (LH): O.E.=51606-S2H-G02      5) 343315 : O.E.=56210-S2H-014 2) 334243 (RH): O.E.=51605-S2H-G51, 334244 (LH): O.E.=51606-S2H-G51      6) 343316 : O.E.=56210-S2H-951 3) 343315 : O.E.=52610-S2H-902 4) 343316 : O.E.=52610-S2J-951									
<b>Integra R</b>									
(DC2)		98-							
<b>Jazz</b>									
		02-		333332 L 333331 R				343381	
<b>Legend</b>									
2.5	(HS)	86- 88		341113 L 341112 R			633173 L 633172 R	333191 L 333190 R	
2.7 2.7	(KA4) (KA3)	89- 90 89- 90		341113 L 341112 R				341116	
<b>Logo</b>									
1.3	(GA3)	3.99-		332107 L 332106 R				343318	
<b>Prelude</b>									
(SN)		79- 82	663040▼				662006▼	362009▼	

\*Excel-G is a new name of SUPER  
 Excel-G ist der neue Name für SUPER  
 Excel-G est le nom nouveau pour SUPER

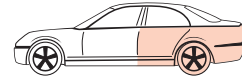
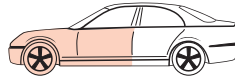

MODEL FAHRZEUG MODELE	YEAR JAHR ANNEE	FRONT/VORNE/AVANT			 1,4	REAR/HINTEN/ARRIERE			 1,4
		PREMIUM Oil	EXCEL-G* Twin-tube Gas	GAS-A-JUST Mono-tube Gas		PREMIUM Oil	EXCEL-G* Twin-tube Gas	GAS-A-JUST Mono-tube Gas	
<b>Honda (J)</b>									
<b>Prelude</b>									
1800 (AB) 2000 (BA2, BA3)	11.82- 87 85- 87		341062		$\frac{\perp}{\otimes}$ 1,4	633096 L 633095 R	333177 L 333176 R		$\frac{\oplus}{\otimes}$ 1,4
2.0 (BA4) Incl.	88- 92		341073 L 341072 R		$\frac{\perp}{\otimes}$ 1,4		341180		$\frac{\perp}{\otimes}$
2.0 (BB3), 2.3 (BB2) 2.2 VTEC (BB1) Incl.	92- 96 93- 96		341178 L 341177 R		$\frac{\perp}{\otimes}$		341179		$\frac{\perp}{\otimes}$
2.0 (BB9), 2.2 (BB5) JHMBB9 ..., BB5...	97- 01		341236 L 341235 R		$\frac{\perp}{\otimes}$		341179		$\frac{\perp}{\otimes}$
2.2 VTEC  (BB8) JHMBB8...	97- 01		341236 L 341235 R		$\frac{\perp}{\otimes}$		341179		$\frac{\perp}{\otimes}$
2.2 VTEC VTI, VTI-R (BB6) JHMBB614..., BB624...	97- 01		341236 L 341235 R		$\frac{\perp}{\otimes}$		341179		$\frac{\perp}{\otimes}$
2.2 VTEC VTIS (BB6) JHMBB615...	97- 01				$\frac{\perp}{\otimes}$		341179		$\frac{\perp}{\otimes}$
<b>Quintet</b>									
	2.80- 84	633034	333021		$\frac{\oplus}{\otimes}$ 1,4	633036 L 633035 R	333023 L 333022 R		$\frac{\oplus}{\otimes}$ 1,4
<b>Shuttle/Odyssey </b>									
2.2 (RA1), 2.3 (RA3)	95-		341201 L 341200 R		$\frac{\perp}{\otimes}$		344274		$\frac{\perp}{\otimes}$
<b>Stream</b>									
(RN1,RN3)	01-		$\diamond$ 331013 L 331012 R $\diamond$		$\frac{\oplus}{\otimes}$		341298		$\frac{\perp}{\otimes}$



MODEL FAHRZEUG MODELE	YEAR JAHR ANNEE	FRONT/VORNE/AVANT				REAR/HINTEN/ARRIERE			
		PREMIUM Oil	EXCEL-G* Twin-tube Gas	GAS-A-JUST Mono-tube Gas		PREMIUM Oil	EXCEL-G* Twin-tube Gas	GAS-A-JUST Mono-tube Gas	
<b>Hyundai (KO)</b>									
<b>Accent, Pony</b>									
ALL Incl. ⊕ ABS	(X3) 7.94- 5.97	633178 L 633177 R	333212 L 333211 R <u>323039 L</u> <u>323038 R</u>		⊕	632104 L <sup>1)</sup> 632103 R <sup>1)</sup>	332081 L <sup>1)</sup> 332080 R <sup>1)</sup> <u>322029 L<sup>1)</sup></u> <u>322028 R<sup>1)</sup></u>		⊕
ALL Incl. ⊕ ABS	(X3) 5.97- 1.00	633178 L 633177 R	333212 L 333211 R <u>323039 L</u> <u>323038 R</u>		⊕	632113 L <sup>2)</sup> 632112 R <sup>2)</sup>	332095 L <sup>2)</sup> 332094 R <sup>2)</sup> <u>322031 L<sup>2)</sup></u> <u>322030 R<sup>2)</sup></u>		⊕
ALL Incl. ⊕ ABS	(LC) 00-		333305 L 333304 R <u>323053 L</u> <u>323052 R</u>		⊕		332109 L 332108 R <u>322033 L</u> <u>322032 R</u>		⊕
1)  1) ø 117 mm      2)  2) ø 173 mm									
<b>Atos</b>									
1.0  ALL Incl. ⊕ ABS	97- 9.98	633205 L 633204 R	333257 L 333256 R		⊕	443300	343301		⊖ ⊖
1.0  ALL Incl. ⊕ ABS	10.98-	633220 L 633219 R	333299 L 333298 R		⊕	443300	343301		⊖ ⊖
<b>Atos Prime</b>									
ALL Incl. ⊕ ABS	8.99-	633220 L 633219 R	333299 L 333298 R		⊕	443300	343301		⊖ ⊖
<b>Coupé (  KMJH..., KMHK... )</b>									
ALL Incl. ⊕ ABS	(J2) 96- 01		333206 L 333205 R <u>323041 L</u> <u>323040 R</u>		⊕		333208 L 333207 R <u>323043 L</u> <u>323042 R</u>		⊕
<b>Elanta </b>									
ALL Incl. ⊕ ABS	(XD) 7.00-		333206 L 333205 R		⊕		333501 L 333500 R		⊕
<b>H 100</b>									
ALL	93-	444128		554095	⊥ ⊖	444023		553116	○ ○

\* Excel-G is a new name of SUPER  
 Excel-G ist der neue Name für SUPER  
 Excel-G est le nom nouveau pour SUPER

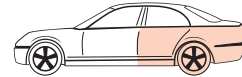
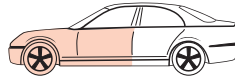

MODEL FAHRZEUG MODELE	YEAR JAHR ANNEE	FRONT/VORNE/AVANT				REAR/HINTEN/ARRIERE			
		PREMIUM Oil	EXCEL-G* Twin-tube Gas	GAS-A-JUST Mono-tube Gas		PREMIUM Oil	EXCEL-G* Twin-tube Gas	GAS-A-JUST Mono-tube Gas	
<b>Hyundai (KO)</b>									
<b>H1 Starex</b>									
<b>SHORT</b> (   ) KMJ...	97-		344285				344287		
<b>LONG</b> (   ) KMJ...	97-		344285				344286		
=  (   ) KMF...	97-		344285				344286		
<b>Lantra</b>									
(J1) Incl.  ABS	12.90- 95	634050	334088			441091	341147		
(J2) Incl.  ABS	95- 3.98	633180 L 633179 R	333206 L 333205 R <u>323041 L</u> <u>323040 R</u>			633182 L 633181 R	333208 L 333207 R <u>323043 L</u> <u>323042 R</u>		
(J2) Incl.  ABS	4.98- 9.00	633180 L 633179 R	333206 L 333205 R <u>323041 L</u> <u>323040 R</u>			633182 L 633181 R	333208 L 333207 R <u>323043 L</u> <u>323042 R</u>		
<b>Matrix</b>									
(FC)	6.01-		333367 L 333366 R				333505 L 333504 R		
<b>Pony, Excel</b>									
Pony 1200, 1400	77- 84	665045	365039			443194	343153	553049	
Pony Excel 1300, 1600 KMHL...	85- 7.89					443087	343176	553048	
Pony 1300, 1500 Excel 1500 KMHU..., KMHV...	(X2) 8.89- 94	633150	333156			443269	343183	553112	
<b>S-Coupe (  KMHU ..., KMHV... )</b>									
(SLC) Exc.GT Turbo	3.90- 96	633150	333156			443269	343183	553112	
GT Turbo (SLC)	90- 96		333156				343183	553112	





MODEL FAHRZEUG MODELE	YEAR JAHR ANNEE	FRONT/VORNE/AVANT				REAR/HINTEN/ARRIERE			
		PREMIUM Oil	EXCEL-G* Twin-tube Gas	GAS-A-JUST Mono-tube Gas		PREMIUM Oil	EXCEL-G* Twin-tube Gas	GAS-A-JUST Mono-tube Gas	
<b>Hyundai (KO)</b>									
<b>Santa Fe</b>									
	7.00-		334501 L 334500 R				344314		
<b>Sonata</b>									
Incl.  ABS KMhaf, KMhbf (Y2)	88- 93	634063	334020			441095	341154		
Incl.  ABS KMhcf, KMhdf	(Y3) 7.93- 99		334141				341192		
Incl.  ABS	(EF) 99- 3.00		341280				341246		
Incl.  ABS	(EF) 4.00-		341280				341281		
<b>Stellar</b>									
	83-12.86	443016	343001	553007		443017	343002	554006	
	87-12.89					443017	343002	554006	
<b>Trajat </b>									
Incl.  ABS (FO)	00-		334238 L 334237 R				344297		
<b>XG30</b>									
Incl.  ABS (XG)	99-		341280				341246		
<b>Isuzu (J)</b>									
<b>Aska </b>									
1800, 2000, Diesel (JJ 110, 120, 510)	83-					443210			
<b>Elf/Elf 250, 350 </b>									
TL 10, 30 (Elf 250) TL 20 (Elf 250)	70- 79 70- 74	444028	344062			444058			

\* Excel-G is a new name of SUPER  
 Excel-G ist der neue Name für SUPER  
 Excel-G est le nom nouveau pour SUPER

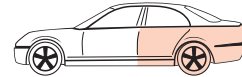
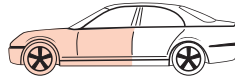

MODEL FAHRZEUG MODELE	YEAR JAHR ANNEE	FRONT/VORNE/AVANT				REAR/HINTEN/ARRIERE			
		PREMIUM Oil	EXCEL-G* Twin-tube Gas	GAS-A-JUST Mono-tube Gas		PREMIUM Oil	EXCEL-G* Twin-tube Gas	GAS-A-JUST Mono-tube Gas	
<b>Isuzu (J)</b>									
<b>Elf/Elf 250, 350</b>									
TL 20 (Elf 250)	75- 79	444028	344062		$\frac{\perp}{\bigcirc}$	444056			$\frac{\bigcirc}{\bigcirc}$
TL 40, 50 (Elf 250)	70- 79	444028	344062		$\frac{\perp}{\bigcirc}$	444057			$\frac{\bigcirc}{\bigcirc}$
KS series (Elf 350)	70- 79	445016			$\frac{\bigcirc}{\bigcirc}$	444058			$\frac{\bigcirc}{\bigcirc}$
<b>Fargo/Midi/Seta</b>									
(WFR series) =	80- 88	444065	344113		$\frac{\perp}{\oplus}$	444040	344114		$\frac{\bigcirc}{\bigcirc}$
(9800 series) =	88-	444065	344113		$\frac{\perp}{\oplus}$	444040	344114		$\frac{\bigcirc}{\bigcirc}$
(9400 series) =	88-				$\frac{\perp}{\oplus}$	444025		554075	$\frac{\bigcirc}{\bigcirc}$
<b>Gemini</b>									
(PF 50, PT 60 series) 1600, 1800	11.74-10.79			553090	$\frac{\perp}{\oplus}$			553089	$\frac{\perp}{\oplus}$
1600, 1800 ZZT, ZZR, LG, LS (PF 60)	10.79- 84			553090	$\frac{\perp}{\oplus}$			553089	$\frac{\perp}{\oplus}$
1300, 1500 (JT 150/600) Exc. Diesel, Turbo-Diesel, Turbo	3.85-	632043 L 632042 R	332035 L 332034 R		$\frac{\oplus}{\oplus}$			552022	$\frac{\perp}{\oplus}$
1500 Diesel, 1500 Turbo-Diesel (JT 150/600) 1500 Turbo (JT 150/600)	7.85- 4.86- 5.87	633066 L 633065 R			$\frac{\oplus}{\oplus}$			552022	$\frac{\perp}{\oplus}$
<b>Lite Elf/Elf 150</b>									
KA 20, 40, 50	68- 8.72	444028	344062		$\frac{\perp}{\bigcirc}$	444023	344102		$\frac{\bigcirc}{\bigcirc}$
KA 41, 51	9.72-	444028	344062		$\frac{\perp}{\bigcirc}$	444056			$\frac{\bigcirc}{\bigcirc}$
<b>Pick-up/Faster/Campo/Brava</b>									
Faster (KB 20, 30 series)	2.72-	443188		553087	$\frac{\perp}{\oplus}$	444025		553058	$\frac{\bigcirc}{\bigcirc}$



MODEL FAHRZEUG MODELE	YEAR JAHR ANNEE	FRONT/VORNE/AVANT				REAR/HINTEN/ARRIERE			
		PREMIUM Oil	EXCEL-G* Twin-tube Gas	GAS-A-JUST Mono-tube Gas		PREMIUM Oil	EXCEL-G* Twin-tube Gas	GAS-A-JUST Mono-tube Gas	
<b>Isuzu (J)</b>									
<b>Pick-up/Faster/Campo/Brava </b>									
Faster   (KBD 2, KBG 2) =	10.80-	443190		553119	$\frac{\perp}{\ominus}$ 1,0	443186		553108	$\frac{\circ}{\circ}$ 1,0
Faster   (KBD 4, KBG 4) =	10.80-	443188		553087	$\frac{\perp}{\ominus}$ 1,0	443186		553108	$\frac{\circ}{\circ}$ 1,0
Campo/Brava (TFR Series)	4.88- 00	443190		553119	$\frac{\perp}{\ominus}$	443295		553230	$\frac{\circ}{\circ}$ 1,0
Campo/Brava (TFS Series)	4.88- 96	443216		553171	$\frac{\perp}{\ominus}$	443295		553230	$\frac{\circ}{\circ}$ 1,0
<b>Trooper/Big Horn </b>									
UBS =	82-10.86	443188		553087	$\frac{\perp}{\ominus}$ 1,0	443211▼ 443186		553108	$\frac{\circ}{\circ}$ 0,8
UBS = Exc.	11.86- 91	444132		554099	$\frac{\perp}{\ominus}$ 1,0	444083		553204	$\frac{\perp}{\circ}$ 1,0
UBS = Exc.	92- 1.98		344279		$\frac{\perp}{\ominus}$ 1,0		344229		$\frac{\ominus}{\circ}$ 0,8
UBS = Exc.	2.98-		344355		$\frac{\perp}{\ominus}$		344229		$\frac{\ominus}{\circ}$ 0,8
<b>Jaguar (GB)</b>									
XJ-6 Daimler Sovereign XJ 12, Sovereign V 12 Daimler Double Six XJS, XJS V 12	68- 86 69- 84 72- 2.93 72- 2.93 75-			553074	$\frac{\perp}{\ominus}$			551022	$\frac{\ominus}{\circ}$
<b>X300 Series</b>									
XJ 6, XJ 12 Daimler Six, Daimler Double Six Exc. Sport,	10.94- 97			553208	$\frac{\perp}{\otimes}$			555007	$\frac{\perp}{\ominus}$
<b>X308 Series</b>									
XJ 8, Daimler XJ8 Incl. Sport sus Exc. ,	10.97-			554114	$\frac{\perp}{\ominus}$			555008	$\frac{\perp}{\ominus}$
XJR Incl. Sport sus Exc. ,	10.97-				$\frac{\perp}{\ominus}$			555008	$\frac{\perp}{\ominus}$

\*Excel-G is a new name of SUPER  
 Excel-G ist der neue Name für SUPER  
 Excel-G est le nom nouveau pour SUPER

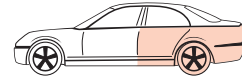
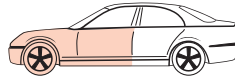

MODEL FAHRZEUG MODELE	YEAR JAHR ANNEE	FRONT/VORNE/AVANT				REAR/HINTEN/ARRIERE			
		PREMIUM Oil	EXCEL-G* Twin-tube Gas	GAS-A-JUST Mono-tube Gas		PREMIUM Oil	EXCEL-G* Twin-tube Gas	GAS-A-JUST Mono-tube Gas	
<b>Jaguar (GB)</b>									
<b>XJ 40, XJ 81 Series</b>									
XJ 6, Sovereign, Daimler (XJ 40) XJ 12, Daimler Double Six (XJ 81) Exc.	10.86- 9.94 2.93- 9.94			553179				551057	
<b>KX8 (QEV), XKR (QDV)</b>									
XK8 XKR Exc.	10.96- 5.98-							555010	
<b>Jeep (US)</b>									
<b>Cherokee, Wagoneer</b>									
Cherokee, Wagoneer (XJ) = 101"	84- 90		344088 ▼ 344392 <u>354002</u> ▼				344089 <u>354003</u> ▼		
Cherokee, Wagoneer (XJ) = 101"	91- 01		344088 ▼ 344393 <u>354002</u> ▼				344089 <u>354003</u> ▼		
Grand Cherokee Grand Wagoneer Exc. Up-Country sus. ()	(ZJ) 92- 98		344088 ▼ 344393				344078 ▼ 344394		
<b>Wrangler</b>									
(YJ Series)	87- 95		344091				344092		
<b>Kia (KO)</b>									
<b>Besta</b>									
	10.92-	444162	344302			443302	343320		
<b>Carnival </b>									
Incl.  ABS (UP)	99- 01		335025 L 335024 R				344296	554145	
<b>Clarus  </b>									
Incl.  ABS (GC)	96- 99	634101 L 634100 R	334232 L 334231 R <u>324018 L</u> <u>324017 R</u>			634103 L 634102 R	334234 L 334233 R <u>324020 L</u> <u>324019 R</u>		

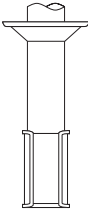
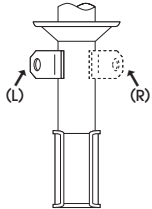

MODEL FAHRZEUG MODELE	YEAR JAHR ANNEE	FRONT/VORNE/AVANT			⚙️ ⌚	REAR/HINTEN/ARRIERE			⚙️ ⌚	
		PREMIUM Oil	EXCEL-G* Twin-tube Gas	GAS-A-JUST Mono-tube Gas		PREMIUM Oil	EXCEL-G* Twin-tube Gas	GAS-A-JUST Mono-tube Gas		
<b>Kia (KO)</b>										
<b>Joice</b> 🚗										
🔌 Incl. ⊕ ABS	(M300E)	99-	634042	334070		⊕	443265	343262		⊕
<b>Pride</b>										
🔌		96-	632111 L 632110 R			⊕	441099			⊕
<b>Rio</b>										
🔌 Incl. ⊕ ABS	(DC)	00-		333503 L 333502 R		⊕		343353		⊕
<b>Sephia</b>										
🔌 ⊖ ABS	(FA)	93- 4.96	633169 L 633168 R	333110 L 333109 R		⊕	633170	333111		⊕
🔌 ⊖ ABS	(FA)	5.96- 99	633169 L 633168 R	333110 L 333109 R		⊕	633170	333111		⊕
🔌 ⊕ ABS	(FA)	93- 4.96	◇ 633249 L 633248 R ◇	◇ 333370 L 333369 R ◇		⊕	◇ 633251 L 633250 R ◇	◇ 333372 L 333371 R ◇		⊕
🔌 ⊕ ABS	(FA)	5.96- 99	◇ 633249 L 633248 R ◇	◇ 333370 L 333369 R ◇		⊕	◇ 633251 L 633250 R ◇	◇ 333372 L 333371 R ◇		⊕
<b>Shuma</b>										
Shuma I 🔌 Incl. ⊕ ABS		98- 3.01		333263 L <sup>1)</sup> 333262 R <sup>1)</sup>  333272L <sup>2)▼</sup> 333273R <sup>2)▼</sup>  333315 L <sup>2)</sup> 333314 R <sup>2)</sup>  323060L <sup>2)</sup> 323059R <sup>2)</sup>		⊕		333265 L 333264 R		⊕
Shuma II 🔌 Incl. ⊕ ABS		5.01-		333317 L 333316 R		⊕		333365 L 333364 R		⊕
1) without stabilizer bracket  2) with stabilizer bracket 										

Kia

\* Excel-G is a new name of SUPER  
 Excel-G ist der neue Name für SUPER  
 Excel-G est le nom nouveau pour SUPER



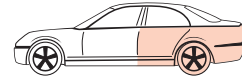
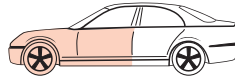

MODEL FAHRZEUG MODELE	YEAR JAHR ANNEE	FRONT/VORNE/AVANT				REAR/HINTEN/ARRIERE			
		PREMIUM Oil	EXCEL-G* Twin-tube Gas	GAS-A-JUST Mono-tube Gas		PREMIUM Oil	EXCEL-G* Twin-tube Gas	GAS-A-JUST Mono-tube Gas	
<b>Kia (KO)</b>									
<b>Sportage</b>									
	9.94- 99		341190		$\frac{\perp}{\otimes}$		344359	554094	$\frac{\perp}{\ominus}$
<b>Kia Commercial (KO)</b>									
<b>Pregio</b>									
2.5D, 2.7D	(FP) 10.97-	441109	341247		$\frac{\perp}{\otimes}$		344292		$\frac{\perp}{\ominus}$
<b>Lada (Shiguli) (RUS)</b>									
<b>110/112</b>									
1100 (2110) 1300 (2110) 1500 (2110/2112)	9.96-	665089	365101		$\frac{\perp}{\square}$	441055	341059		$\frac{\perp}{\ominus}$
<b>Niva </b>									
 (2121)	78-	443122	343097	553121 <u>243015</u>	$\frac{\perp}{\ominus}$ 0,8	443123	343098	553005 <u>243016</u>	$\frac{\circ}{\ominus}$ 0,8
<b>Samara, Riva, Diva, Forma, Sagona </b>									
1100, 1300, 1500 (2108, 2109, 21099)	86-	665059	365057 <u>375037</u>		$\frac{\perp}{\square}$ 1,8	441055	341059 <u>351021</u>		$\frac{\perp}{\ominus}$ 0,7
<b>VAZ, Nova, Toscana </b>									
1200, 1300, 1500, 1600 (2101, 2102, 2103, 2104, 2105, 2106, 2107, 21011, 21061)	70-	443122	343097	553121 <u>243015</u>	$\frac{\perp}{\ominus}$ 0,8	443123	343098	553005 <u>243016</u>	$\frac{\circ}{\ominus}$ 0,8
<b>Lancia (I)</b>									
<b>A112</b>									
	80-	633014	333004		$\frac{\oplus}{\oplus}$ 1,1	633003	333005		$\frac{\oplus}{\oplus}$ 1,3



MODEL FAHRZEUG MODELE	YEAR JAHR ANNEE	FRONT/VORNE/AVANT				REAR/HINTEN/ARRIERE			
		PREMIUM Oil	EXCEL-G* Twin-tube Gas	GAS-A-JUST Mono-tube Gas		PREMIUM Oil	EXCEL-G* Twin-tube Gas	GAS-A-JUST Mono-tube Gas	
<b>Lancia (I)</b>									
<b>Beta, Trevi</b>									
Beta 1300, 1400, 1600, 1800	72- 75		365009 <sup>1)</sup>				365010 <sup>2)</sup>		
Beta 1600, 1800	73- 75						365040 <sup>4)</sup>		
Beta  1300, 1600, 2000 Trevi  1600, 2000	75- 84 80- 84		365009 <sup>1)</sup>				365010 <sup>2)</sup>		
Beta  1600, 2000 Beta  1600, 2000	75- 84		363040 <sup>3)</sup>				365040 <sup>4)</sup>		
1) 365009 : O.E.=82301005, 82346277, 82341690 2) 365010 : O.E.=82287222, 82346273, 82315779, 82341685 3) 363040 : O.E.=82341684, 82327791, 82315777, 82346272 4) 365040 : O.E.=82326804, 82318517, 82341688, 82386804, 82346274									
<b>Dedra (835) </b>									
1.6, 1.8, 2.0, 1.9 TD, 2.0 TD 2.0 Turbo	89- 90- 99		334806 <u>324806</u> 		 1,1		344115	554077 <u>244040</u>	 0,7
2.0 Turbo Integrale	90- 99		334806 <u>324806</u> 		 1,1			554077 <u>244040</u>	 0,7
<b>Dedra (835)  , </b>									
1.6, 1.8, 2.0, 1.9 TD Incl. 16 V Exc.	94- 99		334806 <u>324806</u> 		 1,1		344115	554077 <u>244040</u>	 0,7
<b>Delta (836) </b>									
1.4, 1.6, 1.8, 2.0-16V Exc. 1.9TD, 2.0 HF Turbo	9.93- 99		334806 <u>324806</u> 		 0,8		344115	554077 <u>244040</u>	 0,8
1.9TD	9.93- 99				 0,8		344115	554077 <u>244040</u>	 0,8

\*Excel-G is a new name of SUPER  
 Excel-G ist der neue Name für SUPER  
 Excel-G est le nom nouveau pour SUPER

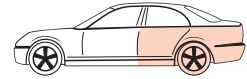
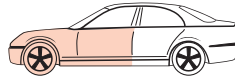

MODEL FAHRZEUG MODELE	YEAR JAHR ANNEE	FRONT/VORNE/AVANT				REAR/HINTEN/ARRIERE																					
		PREMIUM Oil	EXCEL-G* Twin-tube Gas	GAS-A-JUST Mono-tube Gas		PREMIUM Oil	EXCEL-G* Twin-tube Gas	GAS-A-JUST Mono-tube Gas																			
<b>Lancia (I)</b>																											
<b>Delta (836) </b>																											
2.0 HF Turbo	9.93- 99																										
				SM1802 L SM1803 R																							
<b>Delta, Prisma (831)</b>																											
1.3, 1.5, 1.6	2.86-12.92		333844				333846 L 333845 R																				
				SM1809	1,1				1,7																		
1.6D, 1.6TD, 1.9D, 1.9TD 1.6 HF Turbo	2.86-12.92		333844				333846 L 333845 R																				
					1,1				1,7																		
1.3, 1.5, 1.6, 1.6D, 1.6TD, 1.9D, 1.9TD 1.6 HF Turbo	1.93- 8.93		333844				333846 L 333845 R																				
				SM1802 L SM1803 R	1,1				1,7																		
<b>Kappa </b>																											
2.0, 2.0 Turbo, 2.4, 3.0, 2.4 TD Exc.	94- 2.96		335801				335802 <sup>1)</sup>																				
2.0, 2.0 Turbo, 2.4, 3.0, 2.4 TD Exc.	3.96-		335801				335802 <sup>1)</sup>																				
<b>Kappa </b>																											
2.0, 2.0 Turbo, 2.4, 3.0, 2.4 TD Exc.	96-		335801				<b>OE = </b>																				
<b>Lybra  , </b>																											
1.6 1.8	6.99-		334606				343332																				
2.0 1.9JTD 2.4JTD	6.99-		334612				343332																				
<b>Thema  , </b>																											
2.0, 2.0 i.e., 2.0 i.e. Turbo, 2.8 V6 2.5 Turbo Diesel	11.84-10.86		334804																								
				SM1807 <sup>2)</sup> SM1808 <sup>2)</sup>	1,1																						
1) O.E.= 46448417, 46468555, 46457115      2) <table border="1" style="float: right; margin-top: 10px;"> <thead> <tr> <th>Model</th> <th>Year</th> <th>KYB</th> </tr> </thead> <tbody> <tr> <td>2.0 i.e., 2.0 i.e. Turbo</td> <td>10.84 - 5.92</td> <td>SM1807</td> </tr> <tr> <td>2.5 Turbo Diesel / TDS</td> <td>10.84 - 7.94</td> <td>SM1807</td> </tr> <tr> <td>2.8 V6</td> <td>10.84 - 5.92</td> <td>SM1808</td> </tr> <tr> <td>3.0 V6</td> <td>9.92 - 9.94</td> <td>SM1808</td> </tr> <tr> <td>1.9 TDS</td> <td>4.89 - 12.94</td> <td>SM1808</td> </tr> </tbody> </table>										Model	Year	KYB	2.0 i.e., 2.0 i.e. Turbo	10.84 - 5.92	SM1807	2.5 Turbo Diesel / TDS	10.84 - 7.94	SM1807	2.8 V6	10.84 - 5.92	SM1808	3.0 V6	9.92 - 9.94	SM1808	1.9 TDS	4.89 - 12.94	SM1808
Model	Year	KYB																									
2.0 i.e., 2.0 i.e. Turbo	10.84 - 5.92	SM1807																									
2.5 Turbo Diesel / TDS	10.84 - 7.94	SM1807																									
2.8 V6	10.84 - 5.92	SM1808																									
3.0 V6	9.92 - 9.94	SM1808																									
1.9 TDS	4.89 - 12.94	SM1808																									





MODEL FAHRZEUG MODELE	YEAR JAHR ANNEE	FRONT/VORNE/AVANT				REAR/HINTEN/ARRIERE																					
		PREMIUM Oil	EXCEL-G* Twin-tube Gas	GAS-A-JUST Mono-tube Gas		PREMIUM Oil	EXCEL-G* Twin-tube Gas	GAS-A-JUST Mono-tube Gas																			
<b>Lancia (I)</b>																											
<b>Thema</b>																											
2.0 i.e., 2.0 i.e. 16 V, 2.0 i.e. Turbo 2.8 V6, 3.0 V6 Exc. 8.32 (3.0 V8)	11.86- 95		334804				334801																				
			SM1807 <sup>1)</sup> SM1808 <sup>1)</sup>		1,1				2,0																		
<b>Y</b>																											
(840) 1.1, 1.2, 1.4	95-		333914				343269	554086																			
<b>Y10</b>																											
 1000, 1050, 1300, Turbo	3.85- 93	633851 L 633850 R	333867 L 333866 R			441077	341209																				
			913105		1,1																						
 	85- 93	633851 L 633850 R	333867 L 333866 R			441094	341210																				
			913105		1,1																						
 1000, 1050, 1300, Turbo	93- 96	633851 L 633850 R	333867 L 333866 R				341187																				
			913105		1,1																						
 	93- 96	633851 L 633850 R	333867 L 333866 R				341188																				
			913105		1,1																						
<b>Zeta</b>																											
	94- 1.98	634927	334927			443277 <sup>2)</sup>	343296 <sup>2)</sup>																				
			SM1916 L SM1917 R		2,3																						
	1.98- 8.00	634927	334927			443303 <sup>3)</sup>	343321 <sup>3)</sup>																				
			SM1916 L SM1917 R		2,3																						
	9.00-	634927	334927			443303 <sup>3)</sup>	343321 <sup>3)</sup>																				
			SM1918 L SM1919 R		2,3																						
<p>1) <table border="1"> <thead> <tr> <th>Model</th> <th>Year</th> <th>KYB</th> </tr> </thead> <tbody> <tr> <td>2.0 i.e., 2.0 i.e. Turbo</td> <td>10.84 - 5.92</td> <td>SM1807</td> </tr> <tr> <td>2.5 Turbo Diesel / TDS</td> <td>10.84 - 7.94</td> <td>SM1807</td> </tr> <tr> <td>2.8 V6</td> <td>10.84 - 5.92</td> <td>SM1808</td> </tr> <tr> <td>3.0 V6</td> <td>9.92 - 9.94</td> <td>SM1808</td> </tr> <tr> <td>1.9 TDS</td> <td>4.89 - 12.94</td> <td>SM1808</td> </tr> </tbody> </table></p> <p>2)  L max. = 370mm</p> <p>3)  L max. = 400 mm</p>										Model	Year	KYB	2.0 i.e., 2.0 i.e. Turbo	10.84 - 5.92	SM1807	2.5 Turbo Diesel / TDS	10.84 - 7.94	SM1807	2.8 V6	10.84 - 5.92	SM1808	3.0 V6	9.92 - 9.94	SM1808	1.9 TDS	4.89 - 12.94	SM1808
Model	Year	KYB																									
2.0 i.e., 2.0 i.e. Turbo	10.84 - 5.92	SM1807																									
2.5 Turbo Diesel / TDS	10.84 - 7.94	SM1807																									
2.8 V6	10.84 - 5.92	SM1808																									
3.0 V6	9.92 - 9.94	SM1808																									
1.9 TDS	4.89 - 12.94	SM1808																									

\* Excel-G is a new name of SUPER  
 Excel-G ist der neue Name für SUPER  
 Excel-G est le nom nouveau pour SUPER

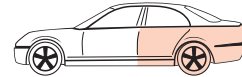
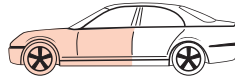

MODEL FAHRZEUG MODELE	YEAR JAHR ANNEE	FRONT/VORNE/AVANT				REAR/HINTEN/ARRIERE			
		PREMIUM Oil	EXCEL-G* Twin-tube Gas	GAS-A-JUST Mono-tube Gas		PREMIUM Oil	EXCEL-G* Twin-tube Gas	GAS-A-JUST Mono-tube Gas	
<b>Landrover (GB)⇒Rover (GB)</b>									
<b>Lexus (J)⇒Toyota (J)</b>									
<b>Mazda (J)</b>									
<b>121</b>									
	(DA)	11.87- 91	632111 L 632110 R	332055 L 332054 R				341079	
	(DB)	91- 96	632088 L 632087 R	332069 L 332068 R				341167	
	(DB)	11.93- 96						341167	
1.25, 1.3 	(AB)	96-		333701 				341952 	
1.25, 1.3 	(AB)	96-		333702 				341952 	
1.8 D 	(AB)	96-		333703 				341952 	
1.8 D 	(AB)	96-		333704 				341952 	
<b>323  (77-80) (  )</b>									
1000, 1300, 1400 (FA4 PS, FA4 TS, FA4 US)		1.77- 6.79	663017	363009			443082		553040 
1000, 1300, 1400 (FA4 PS, FA4 TS, FA4 US)		6.79- 5.80	663018				443082		553040 
<b>323  (78-85) (  )</b>									
1300, 1400 (FA4 TV, FA4 UV)		78- 6.79	663017	363009			443083	343065	
Van 1300 (FA4T6) Station Wagen 1300, 1400 (FA4TV/ UV)		11.79-12.85 6.79- 81	663018				443083	343065	
Station Wagen 1300, 1500	(FA4T/ 4S)	11.81-12.85	663018				443231		
<b>323  (80-89) (  , 4WD )</b>									
1100, 1300, 1500 (BD1011/ 12, BD1031/ 32, BD1051/ 52)		6.80- 85	633011 L 633010 R	333008 L 333007 R			632005 L 632004 R	332010 L 332009 R	



MODEL FAHRZEUG MODELE	YEAR JAHR ANNEE	FRONT/VORNE/AVANT				REAR/HINTEN/ARRIERE			
		PREMIUM Oil	EXCEL-G* Twin-tube Gas	GAS-A-JUST Mono-tube Gas		PREMIUM Oil	EXCEL-G* Twin-tube Gas	GAS-A-JUST Mono-tube Gas	
<b>Mazda (J)</b>									
<b>323  (80-89) ()</b>									
1100, 1300, 1500, 1700 Diesel (BF) Exc. 1500 XG,	7.85- 5.89	633050 L 633049 R	333026 L 333025 R			632035 L 632034 R	332020 L 332019 R		
					1,3				1,9
1500 XG, 1600i (EGI) (BF5P, BFMP) Exc.	7.85- 5.89	633050 L 633049 R	333026 L 333025 R			633112 L 633111 R	333086 L 333085 R		
					1,3				1,9
Heightening Road Clearance (BF) Exc. EGI, H/D	7.85- 5.89	633050 L 633049 R	333026 L 333025 R			632033 L 632032 R	332018 L 332017 R		
					1,3				1,9
1600 Turbo-16V () (BF8) Exc.	6.86- 5.89	633077 L 633076 R				633079 L 633078 R			
					1,3				1,9
<b>323  (86-94) ()</b>									
1300, 1500, 1600, 1700 Diesel (BW12) Exc. ()	1.86-10.95	633050 L 633049 R	333026 L 333025 R			633073 L 633072 R	333073 L 333072 R		
					1,3				1,9
<b>323, 323 C, 323 S  (89-98) Exc. </b>									
(BG) Exc. Heightening Road Clearance	6.89- 8.94	633138 L 633137 R	333127 L 333126 R			633144 L 633143 R	333133 L 333132 R		
Heightening Road Clearance (BG)	6.89- 8.94	633138 L 633137 R	333127 L 333126 R			633089 L 633088 R	333098 L 333097 R		
1.8 i, 1.8 i-Turbo (BG 8 # F/ H) Exc. Hi-Power Engine (BG 83J)	6.89- 8.94	633114 L 633113 R	333088 L 333087 R			633108 L 633107 R	333082 L 333081 R		
(BG 83J) 1.8 i-Turbo GT-R (Hi-Power Engine)	92- 8.94					633108 L 633107 R	333082 L 333081 R		
(BA) 1.3, 1.5, 1.8, 1.7 TD, 2.0 D	9.94- 5.98		333179 L 333178 R				333181 L 333180 R		
1.3,1.5,1.8,1.7 TD,2.0 D (BA) →151007	9.94- 95		333183 L <sup>1)</sup> 333182 R <sup>2)</sup>				333185 L <sup>3)</sup> 333184 R <sup>4)</sup>		
1.3,1.5,1.8,1.7 TD,2.0 D (BA) 151007→	95- 5.98		333179 L 333178 R				333181 L 333180 R		
1)  = BC1D 34 900/900A, BC1F 34 900 2)  = BC1D 34 700/700A, BC1F 34 700 3)  = BC1D 28 900/900A/B/C, BC1F 28 900A/B 4)  = BC1D 28 700/700A/B/C, BC1F 28 700A/B									

\*Excel-G is a new name of SUPER  
 Excel-G ist der neue Name für SUPER  
 Excel-G est le nom nouveau pour SUPER



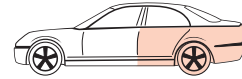
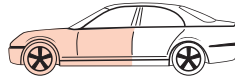

MODEL FAHRZEUG MODELE	YEAR JAHR ANNEE	FRONT/VORNE/AVANT				REAR/HINTEN/ARRIERE			
		PREMIUM Oil	EXCEL-G* Twin-tube Gas	GAS-A-JUST Mono-tube Gas		PREMIUM Oil	EXCEL-G* Twin-tube Gas	GAS-A-JUST Mono-tube Gas	
<b>Mazda (J)</b>									
<b>323 F  (5) (89-)</b>									
(BG) Exc. Heightening Road Clearance	6.89- 8.94		333131 L 333130 R			633144 L 633143 R	333133 L 333132 R		
Heightening Road Clearance (BG)			333131 L 333130 R			633089 L 633088 R	333098 L 333097 R		
(BA) 1.5, 1.8	9.94- 5.98		333179 L 333178 R				333181 L 333180 R		
ABS 1.5, 1.8 →151007	(BA) 9.94- 95		333183 L <sup>1)</sup> 333182 R <sup>2)</sup>				333185 L <sup>3)</sup> 333184 R <sup>4)</sup>		
ABS 1.5, 1.8 151007→	(BA) 95- 5.98		333179 L 333178 R				333181 L 333180 R		
(BA) ABS 2.0	9.94- 5.98		334118 L 334117 R				334120 L 334119 R		
ABS 2.0 →151007	(BA) 9.94- 95		334122 L <sup>5)</sup> 334121 R <sup>6)</sup>				334124 L <sup>7)</sup> 334123 R <sup>8)</sup>		
ABS 2.0 151007→	(BA) 95- 5.98		334118 L 334117 R				334120 L 334119 R		
1.3, 1.5, 1.8, 2.0 D, 2.0 TD Incl.  ABS (BJ)	98-11.00		333275 L 333274 R				333277 L 333276 R		
1.3, 1.5, 1.8, 2.0 D, 2.0 TD Incl.  ABS BJ1###400001→	12.00-		333351 L 333350 R				333277 L 333276 R		
1)  = BC1D 34 900/900A, BC1F 34 900 2)  = BC1D 34 700/700A, BC1F 34 700 3)  = BC1D 28 900/900A/B/C, BC1F 28 900A/B 4)  = BC1D 28 700/700A/B/C, BC1F 28 700A/B 5)  = B01C 34 900 6)  = B01C 34 700 7)  = B01C 28 900/A/B 8)  = B01C 28 700/A/B									
<b>323 P  (3) (98-)</b>									
1.3, 1.5, 2.0 D Incl.  ABS (BA)	5.98- 00		333179 L 333178 R				333181 L 333180 R		
<b>323 S  (4) (98-)</b>									
1.3, 1.5, 1.8, 2.0 D, 2.0 TD Incl.  ABS (BJ)	5.98-11.00		333275 L 333274 R				333277 L 333276 R		



MODEL FAHRZEUG MODELE	YEAR JAHR ANNEE	FRONT/VORNE/AVANT				REAR/HINTEN/ARRIERE			
		PREMIUM Oil	EXCEL-G* Twin-tube Gas	GAS-A-JUST Mono-tube Gas		PREMIUM Oil	EXCEL-G* Twin-tube Gas	GAS-A-JUST Mono-tube Gas	
<b>Mazda (J)</b>									
<b>323 S  (4) (98-)</b>									
1.3, 1.5, 1.8, 2.0 D, 2.0 TD Incl.  ABS BJ1####400001→	(BJ)	12.00-		333351 L 333350 R				333277 L 333276 R	
<b>626, Montrose , ,  Exc. </b>									
1600, 1800, 2000 (CB2NS/ VS/ MS)		10.78- 8.82	663019	363022					553027 
1600, 1800, 2000	(GC)	9.82- 6.85	633029 L 633028 R	333029 L 333028 R			633041	333027	
						1,3			2,1
1600, 1800, 2000	(GC)	7.85- 5.87	633070 L 633069 R	333056 L 333055 R			633041	333027	
						1,3			2,1
1.9, 2.0, 2.0 HP, 2.0 TD 	(GF 1)	97-							
1800, 2000, 2000 Diesel, 2200 Exc.  (4WD)	(GD)	6.87- 92	634025 L 634024 R	334035 L 334034 R			634026	334036	
						1,3			2,1
 2200	(GD)	8.89- 92	634031 L 634030 R	334040 L 334039 R			634033 L 634032 R	334042 L 334041 R	
						1,3			2,1
	(GD)	6.87- 92							
Exc.	(GE 1)	8.91- 93	634045 L 634044 R	334083 L 334082 R			634046	334084	
1800, 2000, 2000 Diesel →271863									
Exc.	(GE 1)	93- 97	634045 L 634044 R	334083 L 334082 R			634080	334157	
1800, 2000, 2000 Diesel 271863→									
	(GE 1)	93- 97	634052 L 634051 R	334090 L 334089 R			634080	334157	
1800, 2000, 2000 Diesel 280356→									
Exc.	(GE 1)	8.91- 97	634045 L 634044 R	334083 L 334082 R			634046	334084	
2500									
Exc.	(GE 7)	9.91- 97	634045 L 634044 R	334083 L 334082 R			634047	334085	
2500									
Exc.	(GE 8)	9.91- 97	634052 L 634051 R	334090 L 334089 R			634049 L 634048 R	334087 L 334086 R	
2000									

\*Excel-G is a new name of SUPER  
 Excel-G ist der neue Name für SUPER  
 Excel-G est le nom nouveau pour SUPER



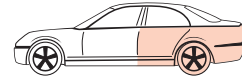
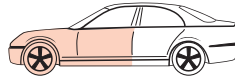

MODEL FAHRZEUG MODELE	YEAR JAHR ANNEE	FRONT/VORNE/AVANT				REAR/HINTEN/ARRIERE			
		PREMIUM Oil	EXCEL-G* Twin-tube Gas	GAS-A-JUST Mono-tube Gas		PREMIUM Oil	EXCEL-G* Twin-tube Gas	GAS-A-JUST Mono-tube Gas	
<b>Mazda (J)</b>									
<b>626, Montrose</b> <b>Exc.</b>									
1.9, 2.0, 2.0 HP, 2.0 TD (GF 1) 	97-		334198 L <sup>1)</sup> 334197 R <sup>2)</sup>				334202 L <sup>5)</sup> 334201 R <sup>6)</sup>		
1.9, 2.0, 2.0 HP, 2.0 TD (GF 1) (Exc. Self Leveling)	97-		334200 L <sup>3)</sup> 334199 R <sup>4)</sup>				334202 L <sup>5)</sup> 334201 R <sup>6)</sup>		
<b>626</b> <b>Exc.</b>									
(GV1) 	88- 97	634025 L 634024 R	334035 L 334034 R			635002	335002		
					1,3				2,1
(GV8) 	10.89- 97	634031 L 634030 R	334040 L 334039 R			635004 L 635003 R	335004 L 335003 R		
					1,3				2,1
(GW 1) 	97-		334198 L <sup>7)</sup> 334197 R <sup>8)</sup>				335029 L <sup>11)</sup> 335028 R <sup>12)</sup>		
(GW 1) (Exc. Self Leveling)	97-		334200 L <sup>9)</sup> 334199 R <sup>10)</sup>				335027 L <sup>13)</sup> 335026 R <sup>14)</sup> 335029 L <sup>13)</sup> 335028 R <sup>14)</sup>		
1) O.E. = GE4T-34-900/-900A 2) O.E. = GE4T-34-700/-700A 3) O.E. = GE4V-34-900/-900A 4) O.E. = GE4V-34-700/-700A 5) O.E. = GE4V-28-900/-900A, GE4T-28-900/-900A 6) O.E. = GE4V-28-700/-700A, GE4T-28-700/-700A 7) O.E. = GF3H-34-900/-900A 8) O.E. = GF3H-34-700/-700A 9) O.E. = GF3J-34-900/-900A 10) O.E. = GF3J-34-700/-700A 11) O.E. = GF3H-28-900/-900A 12) O.E. = GF3H-28-700/-700A 13) O.E. = GF3J-28-900/-900A 14) O.E. = GF3J-28-700/-700A									
<b>929 L, 929</b>									
2000 (LA 2 V, 3 V, 33 W)	8.72- 78	663021	363019					553045	
2000 (LA 4 MV)	78-10.81	665016	365014					553045	
					3,2				0,6
2000 (LA 4 SV)	11.81- 83	665016	365014					553045	
					3,2				0,6
<b>Demio</b>									
(DW) Incl. High Power Exclusive Incl.  ABS	8.98-12.99		333267 L 333266 R				341252		
(DW) Incl. High Power Exclusive Incl.  ABS	1.00-		333267 L 333266 R				341323		
<b>Familia Presto</b> <b>, Rotary Coupé</b>									
1000, 1300 (SPC, STB, SPVC, STBV) (M 10C, FA3T series)	2.72- 2.76		363008			443081		553039	



MODEL FAHRZEUG MODELE	YEAR JAHR ANNEE	FRONT/VORNE/AVANT				REAR/HINTEN/ARRIERE			
		PREMIUM Oil	EXCEL-G* Twin-tube Gas	GAS-A-JUST Mono-tube Gas		PREMIUM Oil	EXCEL-G* Twin-tube Gas	GAS-A-JUST Mono-tube Gas	
<b>Mazda (J)</b>									
<b>Luce, 929 L, 929</b> <b>Exc.</b>									
1800, 2000, 2200 Diesel (HBPH 8, HBPS 2, HBSHE) 	8.81- 9.86	634004 L 634003 R	334032 L 334031 R				343124	553046	
2000, 2000 Turbo (EG i type) (HBSN 2, HBSHE) 	8.81- 9.86	634004 L 634003 R	334032 L 334031 R				341040		
2200 i (HC12) 2000 i (HC12) Exc.	12.86- 91 3.87- 91								
3000 L V 6 Exc.	12.86- 91								
<b>Mazda 6</b>									
(GG/GY)	6.02-		341315 L 341314 R				344363		
<b>MPV</b>									
(LV52) 3.0	93- 99	635010 L 635009 R				445028			
(LV12) 2.5TD,3.0	93- 99	635010 L 635009 R				445028			
(LW)	99-		334283 L 334282 R				345024		
<b>MX-3</b>									
1.6-16V, 1.9-V6 Incl.	(EC) 91-		333251 L 333250 R				333253 L 333252 R		
<b>MX-5</b>									
1600, 1900 Incl.	(NA) 9.89- 98		341143				341127		
1.6-16V, 1.9-16V Incl. , Sport sus. Exc. Limited edition	(NB) 5.98-		341253				341254		
Limited edition 1.6-16V, 1.9-16V Incl.	(NB) 5.98-		O.E.=NC12-34-700C/D				O.E.=NC12-28-700C/D		
<b>MX-6</b>									
(GE 1) 2000, 2500	7.91- 97	634045 L 634044 R	334083 L 334082 R			634046	334084		

\*Excel-G is a new name of SUPER  
Excel-G ist der neue Name für SUPER  
Excel-G est le nom nouveau pour SUPER

= **ULTRASR**

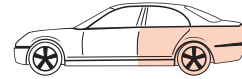
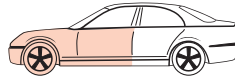

MODEL FAHRZEUG MODELE	YEAR JAHR ANNEE	FRONT/VORNE/AVANT				REAR/HINTEN/ARRIERE			
		PREMIUM Oil	EXCEL-G* Twin-tube Gas	GAS-A-JUST Mono-tube Gas		PREMIUM Oil	EXCEL-G* Twin-tube Gas	GAS-A-JUST Mono-tube Gas	
<b>Mazda (J)</b>									
<b>MX-6</b>									
(GE 7) 7.91- 97	634045 L 634044 R	334083 L 334082 R			634047	334085			
<b>Premacy</b>									
1.9, 2.0 TD (CP) 7.99-		333269 L 333268 R				334260 L 334259 R			
<b>Savanna 808 (RX 3), 818</b>									
(S 124 A) 9.71- 3.78	663017	363009			443084		552007		
(S 124 W) 9.71- 3.78	663017	363009			443083	343065			
<b>Savanna RX 7</b>									
Rotary Coupé (SA 22C) 4.78-11.80		363003				343064	553043		
Rotary Coupé (SA 22C) 12.80-10.85		363010				343064	553043		
Exc.  (FC) 85- 92		334130 L 334129 R					551059		
Exc.  (FD) 92-		341169 L 341168 R				341170			
<b>Tribute</b>									
01-		◇ 334334 L 334333 R ◇				344356			
<b>Xedos 6</b>									
(CA) 92- 99		334280 L 334279 R				334281			
<b>Xedos 9</b>									
(TA) 7.93- 00						341259			





MODEL FAHRZEUG MODELE	YEAR JAHR ANNEE	FRONT/VORNE/AVANT				REAR/HINTEN/ARRIERE			
		PREMIUM Oil	EXCEL-G* Twin-tube Gas	GAS-A-JUST Mono-tube Gas		PREMIUM Oil	EXCEL-G* Twin-tube Gas	GAS-A-JUST Mono-tube Gas	
<b>Mazda Commercial (J)</b>									
<b>E Series/Bongo</b>									
Truck E 2000, 2300, 2500 (EVA, EVB, EVC, EXA, EXB, AEX)	64- 7.71	444062				444066			
Bongo (FSA, FPA)	66- 77	443085		553085				553094	
Bongo (BA 2 series) Exc. Short Box	77- 2.80	443157				443089			
 E1400, E1800	84- 4.97	443215	343215			443179	343214	553120	
 E2000, E2200 	84- 4.97	443215	343215			443179	343214	553120	
 E 2000, E 2200 	84- 4.97	443215	343215			443285		553193	
 E2000, E2200	84- 4.97	444144	344278			443179	343214	553120	
 E2000, E2200	3.97- 99	443215	343215			443179	343214	553120	
 E2000, E2200 	3.97- 99	443215	343215						
 E2000, E2200 	3.97- 99	443215	343215						
 E2000, E2200	3.97- 99	444144	344278			443179	343214	553120	
 E2000, E2200 	3.97- 99	444144	344278						
 E2000, E2200 	3.97- 99	444144	344278						
<b>Pick Up </b>									
800, 1000, 1200 (SSA, BSA 55, SPA, BP, BTA)	63- 73	443085		553085		443081	343066	553039	
1300 (FA2 T)	12.75- 80	443085		553085		443081	343066	553039	

\*Excel-G is a new name of SUPER  
Excel-G ist der neue Name für SUPER  
Excel-G est le nom nouveau pour SUPER

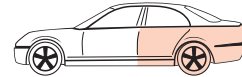
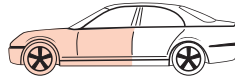

MODEL FAHRZEUG MODELE	YEAR JAHR ANNEE	FRONT/VORNE/AVANT				REAR/HINTEN/ARRIERE			
		PREMIUM Oil	EXCEL-G* Twin-tube Gas	GAS-A-JUST Mono-tube Gas		PREMIUM Oil	EXCEL-G* Twin-tube Gas	GAS-A-JUST Mono-tube Gas	
<b>Mazda Commercial (J)</b>									
<b>Proceed/B Series </b>									
Proceed 1500 (BUD 61)	65- 71	443085		553085		443081	343066		
Proceed 1600 (BNA 61)	71- 76	443110▼				443081	343066		
Proceed 1300, 1800 (BTA 67, PE 2 V 6)	72-	443086		553086		443081	343066		
 B 1600, B 2000, B 2200, B 2600	1.85- 96	443216		553171		443259	343252	553209	
 B 1600, B 2000, B 2200, B 2600	1.85- 96	444135		554100		444136		554101	
 B 2200, B 2500, B 2600	3.96-	443216		553171		443259	343252	553209	
 B 2200, B 2500, B 2600	3.96-	444135		554100		444136		554101	
<b>T Series </b>									
Titan FV, FX, EX, EV (TA 2, 3 series)	8.71-	444062				444066			
Titan Cabin (TA 2 series)	77-	444062				444025		553058	
<b>Mercedes Benz (D)</b>									
<b>190 Series (201)</b>									
190, 190 E, 190 D Exc. 190 E 2.3-16, 2.5-16, Sport sus.	12.82- 93		334017 324007 					553177 243032	
190E 2.3-16V 190E 2.5-16V	9.83- 89 9.88- 5.93		324007 				OE =		
Sport sus. Exc. 190 E 2.3-16V, 2.5-16V	12.82- 93		324007 					243032	

Mercedes



MODEL FAHRZEUG MODELE	YEAR JAHR ANNEE	FRONT/VORNE/AVANT				REAR/HINTEN/ARRIERE			
		PREMIUM Oil	EXCEL-G* Twin-tube Gas	GAS-A-JUST Mono-tube Gas		PREMIUM Oil	EXCEL-G* Twin-tube Gas	GAS-A-JUST Mono-tube Gas	
<b>Mercedes Benz (D)</b>									
<b>A-Class (W168)</b>									
A 140 A 160 A 190 A 160TD A 170TD Incl. ⊕ Sport sus.	9.97-		333944		⊕			551921	⊖
<b>C-Class (W202/T202)</b>									
C 180, C 200, C 220, C 280, C 200 D, C 220 D, C 250 D Exc. Esprit, Sport sus.	6.93- 5.00			553183	⊖ 1,5			553185 Exc.	⊖ 1,4
Esprit, ⊕ Sport sus. C 180, C 200, C 220, C 280, C 200 D, C 220 D, C 250 D	6.93- 5.00			553184	⊖ 1,5			553186 Exc.	⊖ 1,4
C 180, C 200, C 230, C 240, C 280 C 200 D/CDi, C 220 D/CDi, C 250 TD Incl. Sport sus., Esprit	96- 3.01			553184	⊖ 1,5			553185 Exc.	⊖ 1,4
<b>C-Class (W203/T203)</b>									
(W203)	5.00-		335920		⊕				⊖
(T203)	3.01-		335920		⊕				⊖
<b>CLK </b>									
CLK 200, CLK 200K (208) CLK 230K, CLK 320 CLK 430 Exc. Sport sus,	6.97-			553236	⊖			553238	⊖
⊕  (208) CLK 200, CLK 200K CLK 230K, CLK 320K CLK 430 Exc. Sport sus,	6.97-			553236	⊖				⊖
⊕ Sport sus (208) CLK 200, CLK 200K CLK 230K, CLK 320 CLK 430	6.97-			553237	⊖			553238	⊖
<b>E Series (124), E-Class (124)</b>									
200, 200E, 230E, 260E, 300E, 320E, 400E, 200D, 250D, 250 Turbo D, 300D, 300D-Turbo Exc. 4-Matic (4WD), Sport sus.	85- 93		334017 324007 		⊕ 1,8			553178 <u>243032</u> Exc.	⊖ 1,2

Mercedes

\* Excel-G is a new name of SUPER  
Excel-G ist der neue Name für SUPER  
Excel-G est le nom nouveau pour SUPER



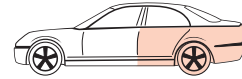
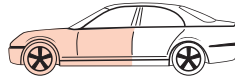

MODEL FAHRZEUG MODELE	YEAR JAHR ANNEE	FRONT/VORNE/AVANT				REAR/HINTEN/ARRIERE			
		PREMIUM Oil	EXCEL-G* Twin-tube Gas	GAS-A-JUST Mono-tube Gas		PREMIUM Oil	EXCEL-G* Twin-tube Gas	GAS-A-JUST Mono-tube Gas	
<b>Mercedes Benz (D)</b>									
<b>E Series (124), E-Class (124)</b>									
230CE, 300CE, 320CE Exc. Sport sus.	87- 93		334017 324007 					553178 243032 Exc.	
200T, 230TE, 280TE, 300TE, 320TE, 200TD, 250TD, 300TD-Turbo Exc. Sport Sus., 4-Matic (4WD)	85- 93		334017 324007 				OE =		
E200, E220, E280, E320, E420, E200D, E250D, E250D-Turbo, E300D, E300D-Turbo Exc. 4-Matic (4WD), Sport sus.	93- 95		334017 324007 					553178 243032 Exc.	
E220C, E320C Exc. Sport sus.	93- 95		334017 324007 					553178 243032 Exc.	
E200T, E220T, E280T, E320T, E250TD, E300TD, E300TD-Turbo Exc. Sport sus., 4-Matic (4WD)	93- 95		334017 324007 				OE =		
Sport sus.  Exc. 4-Matic (4WD)	85- 95 87- 95		324007 					243032 Exc.	
Sport sus.  Exc. 4-Matic (4WD)	85- 95		324007 				OE =		
<b>E-Class (210)</b>									
E200, E230, E240, E280, E320, E420, E430 E 220 D, E 250 D, E 290 TD, E 300 D Exc. Avantgarde, Sport sus.	7.95- 2.02			553197				553198 Exc.	
Avantgarde,  Sport sus. E200, E230, E240, E280, E320, E420, E430 E 220 D, E 250 D, E 290 TD, E 300 D	7.95- 2.02			553199				553200 Exc.	
E200, E230, E240, E280, E320, E420, E430 E 220 CDi, E 290 TD, E 300 TD Exc. Avantgarde, Sport sus.	96-			553197			OE =		
Avantgarde,  Sport sus. E200, E230, E240, E280, E320, E420, E430 E 220 CDi, E 290 TD, E 300 TD	96-			553184			OE =		



MODEL FAHRZEUG MODELE	YEAR JAHR ANNEE	FRONT/VORNE/AVANT				REAR/HINTEN/ARRIERE			
		PREMIUM Oil	EXCEL-G* Twin-tube Gas	GAS-A-JUST Mono-tube Gas		PREMIUM Oil	EXCEL-G* Twin-tube Gas	GAS-A-JUST Mono-tube Gas	
<b>Mercedes Benz (D)</b>									
<b>G-Class (-8.93)</b>									
200GE (460)	85- 90	445029			⊖ T	445033			⊥ ⊖
230G (460.2)	2.79- 90				0.8				1.1
230GE (460.21/23/24)	2.79- 90								
230GE (460.220/221/228)	2.79- 90								
240GD (460.31/320/33/34)	2.79- 90								
250GD (460.31/328/33)	85- 90								
280GE (460)	2.79- 90								
300GD (460.31/322/33/34)	2.79- 90								
200GE (463.200/220/221)	90- 8.93	445030			⊖ T	445033			⊥ ⊖
230GE (463)	90- 8.93				0.8				1,1
250GD (463.304/324/325)	90- 8.93								
250GD-TD (463)	9.91- 8.93								
290GD (463)	92- 8.93								
300GD (463.307/327/328)	90- 8.93								
300GE (463.207/227/228)	90- 8.93								
300GD-TD (463.300/320/321)	9.92- 8.93								
500GE (463.228)	92- 8.93								
Exc.									
⊕		445032			⊖ T	445034			⊥ ⊖
200GE (463.200/220/221)	90- 8.93				0.8				1,1
230GE (463)	90- 8.93								
250GD (463.304/324/325)	90- 8.93								
250GD-TD (463)	9.91- 8.93								
290GD (463)	92- 8.93								
300GD (463.307/327/328)	90- 8.93								
300GE (463.207/227/228)	90- 8.93								
300GD-TD (463.300/320/321)	9.92- 8.93								
500GE (463.228)	92- 8.93								
230GE (406.229)	2.79- 90	445031			⊖ T	445034			⊥ ⊖
240GD (460.321)	2.79- 90				0.8				1,1
250GD (460.329)	85- 90								
250GD (461.40)	90- 8.93								
300GD (460.323/325)	2.79- 90								
<b>G-Class (9.93-)</b>									
G230 (461.227)	9.93-	445031			⊖ T	445034			⊥ ⊖
G290D (461.329)	9.93-				0.8				1,1
G230 (463.224/225)	9.93-	445030			⊖ T	445033			⊥ ⊖
G230 Cabrio (463.204)	9.93-				0.8				1,1
G290D (461.328)	9.93-								
G290D (461.337/338/341)	9.93-								
G300 (463.207/227/228)	9.93-								
G300D (463.307/327/328)	9.93-								
G300TD (463)	10.96-								
G320 (463.230/231)	94-								
G350TD (463.300/320/321)	9.93-								
G500 (463.228)	9.93-								
Exc.									

Mercedes

\*Excel-G is a new name of SUPER  
 Excel-G ist der neue Name für SUPER  
 Excel-G est le nom nouveau pour SUPER



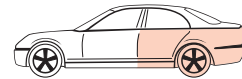
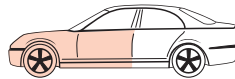

MODEL FAHRZEUG MODELE	YEAR JAHR ANNEE	FRONT/VORNE/AVANT				REAR/HINTEN/ARRIERE			
		PREMIUM Oil	EXCEL-G* Twin-tube Gas	GAS-A-JUST Mono-tube Gas		PREMIUM Oil	EXCEL-G* Twin-tube Gas	GAS-A-JUST Mono-tube Gas	
<b>Mercedes Benz (D)</b>									
<b>G-Class (9.93-)</b>									
G230 (463.224/225) 9.93- G230 Cabrio (463.204) 9.93- G290D (461.328) 9.93- G290D (461.337/338/341) 9.93- G300 (463.207/227/228) 9.93- G300D (463.307/327/328) 9.93- G300TD (463) 10.96- G320 (463.230/231) 94- G350TD (463.300/320/321) 9.93- G500 (463.228) 9.93-		445032				445034			
G290D (461.323/367/368) 9.93-		445032				445034			
<b>Passenger Cars (W-series)</b>									
220 b, 220 Sb (W 111) 60- 65 220 SEb / Coupé & Cabrio (W 110) 60- 65 190 c, 190 Dc (W 110) 62- 65 230, 230 S (W 110) 65- 67 200, 200D (W 110) 65- 67			341001	551016			344001	554003	
300 SEb (W 109) 65- 72 300 SE (W 113) 65- 72 230 SL, 250 SL (W 113) 63- 72 280 SL (W 113) 68- 72 250 S, 250 SE Coupé & Cabrio 65- 68				551016				554003	
200,200D,220,220D,230 (W 115) 68- 76 250, 250 C, 250 CE (W 114) 71- 76 280, 280 C, 280 CE, 280 E 73- 76 230/4, 240 D, 240 D/3.0		441021	341002	551017		444034	344002	554004	
280 SL, 280 SLC (W 107) 74- 81 350 SL, 350 SLC 10.71- 81 350 SL 4.5, 350 SLC 4.5 72- 2.73 450 SL, 450 SLC 74- 81				551017				554004	
(123) 76-12.84 200, 200 D, 220 D, 230, 230 C, 240 D 250, 280, 280 C, 280 CE, 280 E, 300 D				551018				554004	
(123) 10.77- 85 230 T, 250 T, 280 TE, 240 TD, 300 TD				551018			OE =		
<b>S Series</b>									
(W108) 68- 8.72 250 S, 280 S, 280 SE, 280 SEL				551016				554003	
(W 116) 9.72- 80 280S, 280SE, 280SEL, 350SE 3.73- 80 450 SE, 450 SEL, 450 SEL 6.9				551018				554004	
(W 126) 80- 91 280 S, 280 SE, 280 SEL, 380 SE, 380 SEL, 500 SE, 500 SEL				551018			344002 Exc.	554004	



MODEL FAHRZEUG MODELE	YEAR JAHR ANNEE	FRONT/VORNE/AVANT				REAR/HINTEN/ARRIERE			
		PREMIUM Oil	EXCEL-G* Twin-tube Gas	GAS-A-JUST Mono-tube Gas		PREMIUM Oil	EXCEL-G* Twin-tube Gas	GAS-A-JUST Mono-tube Gas	
<b>Mercedes Benz (D)</b>									
<b>S Series</b>									
(W 126) 380 SEC, 500 SEC	9.81-			551017				554004	
<b>SLK </b>									
SLK 200, SLK 200K SLK 230	(170) 96-			553237				553245	
<b>V-Class </b>									
(638) Exc.	9.96-						343305		
<b>Mercedes Benz Commercial (D)</b>									
<b>200,300,400 Series</b>									
L206D,L206DG,L207 L306D, L306DG, L307	(605) (606)		443168				443169		
L208,L210 L207D,L208D,L209D,L210D L308,L310 L307D,L308D,L309D,L310D	(601) (601) (602) (602)		443170				441081		
L319B,L319D L405, L406, L406D,L408, L409	(309) (309)		445014				445014		
L406D	(310)		444154				444154		
L408D	(611)		444154				444154		
L406DG (309.100-103/111-116/124-126) L407D (309.100-103/111-116/124-126) LK 406DG,LK407D (309.140/141/144)			444147				444147		
L408G,L409,L410 (309.000-026) L408DG (309.300-303/311-316/324-326) LF408G (309.054/055) LK408G,LK409,LK410 (309.040/041/044) LKO406DG,LKO407D (309.130-135) LKO408G,LKO409 (309.030-035)			444146				444146		
LF408G,LF409,LF410 (309.050) 005094 → 148036			444146				444146		
LF408G,LF409,LF410 (309.050) 148037 → 526086			444146				444147		

\*Excel-G is a new name of SUPER  
 Excel-G ist der neue Name für SUPER  
 Excel-G est le nom nouveau pour SUPER



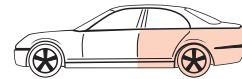
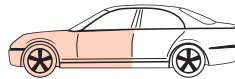

MODEL FAHRZEUG MODELE	YEAR JAHR ANNEE	FRONT/VORNE/AVANT				REAR/HINTEN/ARRIERE			
		PREMIUM Oil	EXCEL-G* Twin-tube Gas	GAS-A-JUST Mono-tube Gas		PREMIUM Oil	EXCEL-G* Twin-tube Gas	GAS-A-JUST Mono-tube Gas	

## Mercedes Benz Commercial (D)

### 200,300,400 Series

LF408G,LF409,LF410 (309.050) 526087 →		444146				444146			
LF408G,LF409,LF410 (309.056/059) 148037 → 185439		444146				444147			
LF408G,LF409,LF410 (309.056/059) 185440 → 275292		444146				444146			
LF408G,LF409,LF410 (309.056/059) 275293 → 526086		444147				444147			

### 500,600,700,800 Series

L508D,L508DG (310) L613 (310)		444154				444154			
LT608D (310,100)		444146							
L508D (309.400-405/411-416/424-427/429) L508DG (309.400-405/411-416/424-427/429) LF508D (310.350) LK508D (309.440-442/444/445) LKO508DG (309.430-433/435) L608D (310.000-305/311-316/324-327/329) L608D (310.400-405/424-427/429) LF608D (310.350) LK608D (310.340-345/440-445) L613D (313)		444146				444146			
507D (667.301/302/341/342/361/362) 508D (667.301/302) 510 (667.001/002/061/062)		444145 <sup>1)</sup>							
512D (667.321-323/351-353) 609D (668.001-003/041/042/061-063) 709D (669.001-003/041/042/061-063) 711D (669.302/303/362/363) 809D (670.001-003/041/042/061-063) 811D (670.302/303/362/363) 814D (670.312/313/364-366)		444145							
614D		444145							

1)



Lmax = 633 mm





MODEL FAHRZEUG MODELE	YEAR JAHR ANNEE	FRONT/VORNE/AVANT				REAR/HINTEN/ARRIERE			
		PREMIUM Oil	EXCEL-G* Twin-tube Gas	GAS-A-JUST Mono-tube Gas		PREMIUM Oil	EXCEL-G* Twin-tube Gas	GAS-A-JUST Mono-tube Gas	
<b>Mercedes Benz Commercial (D)</b>									
<b>500,600,700,800 Series</b>									
LP608,LP709 (314.051-053/055-060) LPS608,LPS709 (314.063) LPK608,LPK709 (314.072) LPKF608,LPKF709 (314.081-083) LPKO608,LPKO709 (314.077) LPO608,LPO709 (314.085-087)						444154			
808L,LPK,LPKF,LPO (316) 809LP,LPK,LPKF,LPO (316)						444154			
<b>MB Series</b>									
MB100D (631)	84-	443272				444126			
MB140, MB 160, MB180 (631)	84-	443273				444127			
<b>O309,O310</b>									
O309B (309) O309D (309)		444146 <sup>1)</sup>				444146 <sup>1)</sup>			
O309D (310, 313, 323)		444154				444154			
O309D (602) O310D (602)		443170				441081			
1)  Lmax = 625 mm									
<b>O609,O611,O614</b>									
O609D,O611D,O614D (672)		444145							
<b>Sprinter</b>									
208D (901.311/312/361/362/371/372) 208D (902.311/312/322/361/362/371/372) 212D (901.461/462/471/472) 212D (902.411/412/422/461/462/471/472) 214 (901.011/012/061/062/071/072) 214 (902.011/012/022/061/062/071/072) 308D (903.311-313/322/323/361-363/371-373) 312D (903.411-413/422/423/461-463/471-473) 314 (903.011-013/022/023/061-063/071-073)	2.95-		335915			441081			

\*Excel-G is a new name of SUPER  
 Excel-G ist der neue Name für SUPER  
 Excel-G est le nom nouveau pour SUPER

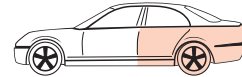
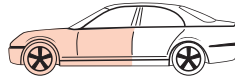

MODEL FAHRZEUG MODELE	YEAR JAHR ANNEE	FRONT/VORNE/AVANT				REAR/HINTEN/ARRIERE			
		PREMIUM Oil	EXCEL-G* Twin-tube Gas	GAS-A-JUST Mono-tube Gas		PREMIUM Oil	EXCEL-G* Twin-tube Gas	GAS-A-JUST Mono-tube Gas	
<b>Mercedes Benz Commercial (D)</b>									
<b>Sprinter</b>									
408D 410 411D 412D (904.412/413/422/423/462/463) 414 (904.012/013/022/023/062/063) 416CDI	2.96-		335914		⊕	444262			⊖
<b>Vito</b>									
(638) Exc.	9.96-						343305		⊖
<b>Mercury (US) ⇒ Ford (US)</b>									
<b>Mitsubishi (J)</b>									
<b>Carisma</b>									
1.6, 1.9 TD Incl. ⊕ ABS Exc. 6B Model	5.95- 2.99		333222 L 333221 R		⊕		341204		⊖
1.8 (85 kw, 103 kw), 1.8 GDI (92 kw) Incl. ⊕ ABS Exc. 6B Model	5.95- 2.99		334155 L 334154 R		⊕		341204		⊖
1.6, 1.8GDI, 1.9TD 	3.99- 6.00		334309 L 334308 R		⊕		341204		⊖
1.6, 1.8GDI, 1.9DI-D 	7.00-		334309 L 334308 R		⊕		341204		⊖
<b>Colt - Mirage</b>									
1200, 1400 (A 150 series) Exc. Turbo	11.77- 84	665018	365027		□ 2,0	443087	343176	553048	⊖ ⊖ 0,8
1400 Turbo (A 152)	12.78- 84	665018	365027		□ 2,0		343183	553112	⊖ ⊖ 0,8
<b>Colt</b>									
1200 (C 15A), 1500 (C 12A) 1600 Turbo (C 13A), 1800 Diesel (C 14A)	1.84-11.85	633040	333024		⊕ 1,4	442029 OE = MB 242818	342014	552017	⊖ ⊖ 0,8
1200 (C 15A), 1500 (C 12A), 1600 Turbo (C 13A), 1800 Diesel (C 14A)	12.85- 5.86	633040	333024		⊕ 1,4	443250 OE = MB 515097	343232	553165	⊖ ⊖ 0,8
1200 (C 15A), 1300 (C 11A) 1800 Diesel (C 14A)	6.86- 6.88	633059	333037		⊕ 1,4	443250 OE = MB 515097	343232	553165	⊖ ⊖ 0,8

Mitsubishi



MODEL FAHRZEUG MODELE	YEAR JAHR ANNEE	FRONT/VORNE/AVANT				REAR/HINTEN/ARRIERE			
		PREMIUM Oil	EXCEL-G* Twin-tube Gas	GAS-A-JUST Mono-tube Gas		PREMIUM Oil	EXCEL-G* Twin-tube Gas	GAS-A-JUST Mono-tube Gas	
<b>Mitsubishi (J)</b>									
<b>Colt </b>									
1500 (C 12A) 1600 Turbo / ECI Turbo (C 13A) Exc. (S) (C 12A/13A *** PL 6)	6.86- 2.89	633059	333037			443250	343232 OE = MB 515097	553165	
(S) 1500 (C 12A **JPL 6)	6.86- 5.87	633040	333024			443250	343232 OE = MB 515097	553165	
(S) 1600 Turbo (C 13 AMNJPL 6)	6.86- 5.87	633040	333024			442029	342014 OE = MB 242818	552017	
1300 (C 51A/V), 1500 (C 52A) 1800 Diesel (C 54A)	4.88-11.88	634029	334019 			441079	341084		
1300 (C 51A/V), 1500 (C 52A) 1600 GTi-16V (C 53A) 1800 GTi-16V (C 58A)	12.88- 92 4.88- 5.90 11.89- 92		334019 				341084		
 1800 Diesel (C54A) Exc. High Ground Clearance sus.	12.88- 92		334019 				341084 OE = MB631341,MB631342		
  1800 Diesel (C54A)	12.88- 92		334019 				341071 OE = MB 584403		
1300, 1600 (CA 1A, CA 4A) Exc. High Ground Clearance sus.	12.91- 96	633148 L 633147 R	333125 L 333124 R			441085	341140 OE = MB809270		
 1300, 1600 (CA 1A, CA 4A)	12.91- 96	633148 L 633147 R	333125 L 333124 R				341145 OE = MB891463		
1800 GTi (CA 5A)	12.91- 96		334073 L 334072 R			441085	341140		
 1600(CC4A)	12.91- 96	633148 L 633147 R	333125 L 333124 R			441085	341140		
 1300, 1500, 1600 (CJ1, CJ2, CJ4) Exc. High Ground Clearance sus.	96- 3.97		333225 L 333224 R				341140		
1300 (CJ1) Exc. High Ground Clearance sus.	4.97-		332113 L 332112 R				341140		
1600 (CJ4) Exc. High Ground Clearance sus.	4.97-		333319 L 333318 R				341140		
  1300, 1500, 1600 (CJ1, CJ2, CJ4)	96- 3.97						341145		

\*Excel-G is a new name of SUPER  
Excel-G ist der neue Name für SUPER  
Excel-G est le nom nouveau pour SUPER

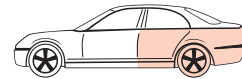
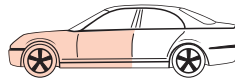

MODEL FAHRZEUG MODELE	YEAR JAHR ANNEE	FRONT/VORNE/AVANT				REAR/HINTEN/ARRIERE			
		PREMIUM Oil	EXCEL-G* Twin-tube Gas	GAS-A-JUST Mono-tube Gas		PREMIUM Oil	EXCEL-G* Twin-tube Gas	GAS-A-JUST Mono-tube Gas	
<b>Mitsubishi (J)</b>									
<b>Colt</b>									
⊕ High Ground Clearance sus.	4.97- 1300, 1600 (CJ1, CJ4)								
<b>Cordia &amp; Tredia</b>									
 1400, 1500, 1600, 1800 (A 210 series) Exc. Turbo	2.82- 87	634001	334001		⊕ 1,4	443087	343176	553048	⊖ 0,8
 1600 Turbo (A 212), 1800 Turbo (A 213)	2.82- 87	634001	334001		⊕ 1,4		343183	553112	⊖ 0,8
 Tredia 1800 (A 215 G), 2000 (A 217 G)	85- 87	634006	334033		⊕ 1,4		343183	553112	⊖ 0,8
<b>Eclipse</b>									
(D 21A, D 22A) 1800, 2000, 2000 Turbo Incl. ⊕ ABS	1.90- 3.94		334030 		⊕		341114		⊖ 0,8
(D 27A) 2000 Incl. ⊕ ABS	4.91- 3.94		334030 		⊕		341121		⊖ 0,8
 2000 (D 32A)	8.95-		341163		⊖ 0,8		341165		⊖ 0,8
<b>Galant, Sapporo (Lambda), Sigma</b>									
1600, 2000, 2600 (A 120, 130 series)	5.76- 5.80		365004		⊖ 2,6			553053	⊖ 0,8
1600, 1800, 2000 (A 161, 162, 163)	6.80- 7.84	665039	365028		⊖ 2,6		343057	553078	⊖ 0,8
2000 Royal (A 164) Exc. Turbo 2600 (A 166)	6.80- 7.83	665040	365029		⊖ 2,6	665041	365020		⊖ 0,8
2000 Turbo (Lambda) (A 164)	11.80- 8.83		365029		⊖ 2,6				⊖ 0,8
2300 Turbo Diesel (A 167)	6.80- 8.83	665040	365029		⊖ 2,6		343057	553078	⊖ 0,8
1600 Exc.	(E11A) 8.83- 87	634005	334002		⊕ 1,4	441053	341054	551036	⊖ 1,4
1800 Turbo Diesel 2000, 2000 Turbo 2400 Exc. ⊕ ABS,	(E14A) (E15A) (E16A) 8.83- 87	634007	334003		⊕ 1,4	441053	341054	551036	⊖ 1,4

\*Excel-G is a new name of SUPER  
Excel-G ist der neue Name für SUPER  
Excel-G est le nom nouveau pour SUPER

Mitsubishi



MODEL FAHRZEUG MODELE	YEAR JAHR ANNEE	FRONT/VORNE/AVANT				REAR/HINTEN/ARRIERE			
		PREMIUM Oil	EXCEL-G* Twin-tube Gas	GAS-A-JUST Mono-tube Gas		PREMIUM Oil	EXCEL-G* Twin-tube Gas	GAS-A-JUST Mono-tube Gas	
<b>Mitsubishi (J)</b>									
<b>Galant, Sapporo (Lambda), Sigma</b>									
(2WD) Incl. ⊕ ABS 1600 (E 31A), 1800 (E 32A) 2000, 2000 GTi-16V (E 33A) 1800 Diesel Turbo (E 34A) Exc.	12.87- 92	634023	334030			441053	341054		
					1,4				
(4WD) ⊖ ABS 2000, 2000 GTi-16V (E 38A, E 39 A) Incl. ⊕	6.88- 92	634034	334043			441078	341121		
					1,4				
(4WD) ⊕ ABS 2000, 2000 GTi-16V (E 38A, E 39 A) Incl. ⊕	6.88- 5.90	634034	334043			441078	341121		
					1,4				
(4WD) ⊕ ABS 2000, 2000 GTi-16V (E 38A, E 39 A) Incl. ⊕	6.90- 92	634035	334044			441078	341121		
					1,4				
(2WD), (4WD) Incl.	11.92- 96	441086	341141			441087	341142		
1800 (E52A) 2000 (E55A, E 75A) 2000-24V (E54A, E 64A) 2000 Diesel Turbo (E57A) 2500-24V (E88A) Incl. H/D , High Ground Clearance sus. Exc.									
(2WD) (EA2A, EA5A, EA6A) 2000, 2500, 2000 Turbo Diesel Incl. H/D	10.96-		341141				341213 Exc.		
<b>Galant, Sapporo (Lambda), Sigma</b>									
1300, 1500 (A 51 V, 52 V, 53 V)	12.69- 3.73	665020	365004			443066	343121	553083	
1600 (A 112 V)	4.73-12.76	665020	365004			443070	343060		
1600, 2000 (A 121 V, 123 V)	77- 5.80	665020	365004			443094	343061		
					2,6				
1600, 2000 (A 121 V, A 163 V, A 161 V, A 168 V)	6.80- 8.83	665039	365028			443094	343061		
					2,6				
(2WD) (EA2W, EA5W, EA6W) 2000, 2500, 2000 Turbo Diesel Incl. H/D	10.96-		341141						
<b>Lancer</b>									
1200, 1400 (A 75, 72)	1.73- 8.76					443194	343153	553049	

\*Excel-G is a new name of SUPER  
Excel-G ist der neue Name für SUPER  
Excel-G est le nom nouveau pour SUPER

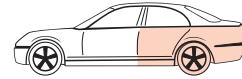
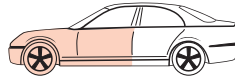

MODEL FAHRZEUG MODELE	YEAR JAHR ANNEE	FRONT/VORNE/AVANT				REAR/HINTEN/ARRIERE			
		PREMIUM Oil	EXCEL-G* Twin-tube Gas	GAS-A-JUST Mono-tube Gas		PREMIUM Oil	EXCEL-G* Twin-tube Gas	GAS-A-JUST Mono-tube Gas	
<b>Mitsubishi (J)</b>									
<b>Lancer</b>									
1600 (A 73)	1.73- 8.76					443194	343153	553049	
1200, 1400 (A 72, 75, 141 A, 142 A)	9.76-12.78	663024	363020			443089		553049	
1400, 1600 (A 172, 174)	1.79-12.80	665020	365004		 2,6	443090	343031	553050	 0,8
1400, 1600, 1800 (A 172, 174, 175) Exc. Turbo	1.81- 9.83	665020 663025 <sup>1)</sup>	365004 363007 <sup>1)</sup>		 2,6		343063	553081	 0,8
1800 Turbo (A 175)	10.81- 9.83						343063	553081	 0,8
2000 Turbo (A 176)	5.81- 83	665040	365029		 2,6		343063	553081	 0,8
1200 (C 15A), 1500 (C 12A) 1600 Turbo (C 13A), 1800 Diesel (C 14A)	1.84-11.85	633040	333024		 1,4	442029	342014 OE = MB 242818	552017	 0,8
1200 (C 15A), 1500 (C 12A) 1600 Turbo (C 13A), 1800 Diesel (C 14A)	12.85- 5.86	633040	333024		 1,4	443250	343232 OE = MB 515097	553165	 0,8
1200 (C 15A), 1300 (C 11A) 1800 Diesel (C 14A)	6.86- 6.88	633059	333037		 1,4	443250	343232 OE = MB 515097	553165	 0,8
1500 (C 12A) 1600 Turbo/ECI Turbo (C 13A) Exc.  (C 12A/13A *** PL 6)	6.86- 2.89	633059	333037		 1,4	443250	343232 OE = MB 515097	553165	 0,8
 1500 (C 12A **JPL 6)	6.86- 5.87	633040	333024		 1,4	443250	343232 OE = MB 515097	553165	 0,8
 1600 Turbo (C 13AMNJPL 6)	6.86- 5.87	633040	333024		 1,4	442029	342014 OE = MB 242818	552017	 0,8
1200 (C 65A), 1300 (C 61A) 1500 (C 62A), 1800 Diesel (C 64A)	4.88-11.88	634029	334019 		 1,4	441079	341084		 1,4
 1200 (C 65A), 1800 Diesel (C64A) 1600 GTI-16V (C 63A) 1800 GTI-16V (C 68A)	12.88- 92 4.88- 5.90 11.89- 92		334019 		 1,4		341084		 1,4
1) OE= MB 002190									

Mitsubishi



MODEL FAHRZEUG MODELE	YEAR JAHR ANNEE	FRONT/VORNE/AVANT			⚙️ ⌚	REAR/HINTEN/ARRIERE			⚙️ ⌚
		PREMIUM Oil	EXCEL-G* Twin-tube Gas	GAS-A-JUST Mono-tube Gas		PREMIUM Oil	EXCEL-G* Twin-tube Gas	GAS-A-JUST Mono-tube Gas	
<b>Mitsubishi (J)</b>									
<b>Lancer</b> 🚗, 🚗									
2WD 1300 (C61A),1500(C62A) Exc. High Ground Clearance sus. (🚗)	12.88- 95		334019 917302		⊕ 1,4		341084 OE= MB 631340,MB631341,MB631342		⊥ ⊕ 1,4
2WD ⊕ High Ground Clearance sus. (🚗) 1300 (C61A), 1500 (C62A)	12.88- 95		334019 917302		⊕ 1,4		341071 OE = MB 584403,MB911458		⊥ ⊕ 1,4
2WD 1600 (C66A),1800 GTi (C69A) 2000 Diesel (C67A)	6.92- 95		334019 917302		⊕ 1,4		341084		⊥ ⊕ 1,4
4WD 1800 (C 77A)	5.89- 92		334049		⊕ 1,4		341114		⊥ ⊕ 1,4
4WD 1600 (C76A)	6.92- 95		334049		⊕ 1,4		341114		⊥ ⊕ 1,4
2WD 1300, 2000 Diesel (CB 1A, CB 8A) 1500,1600 (CB2A,CB4A) Exc. High Ground Clearance sus. (🚗)	5.92- 96 5.92-	633148 L 633147 R	333125 L 333124 R		⊕	441085	341140 OE= MB 809271,MB809272,MB914897		⊥ ⊕
2WD ⊕ High Ground Clearance sus. (🚗) 1300, 2000 Diesel (CB 1A,CB 8A) 1500,1600 (CB2A, CB4A)	5.92- 96 5.92-	633148 L 633147 R	333125 L 333124 R		⊕		341145 OE = MB891463		⊥ ⊕
4WD 1600 (CD 4A)	5.92- 93		333125 L 333124 R		⊕	441085	341140		⊥ ⊕
2WD 1800 GTi (CB 5A)	5.92- 96		334073 L 334072 R		⊕	441085	341140		⊥ ⊕
2WD 1300, 1500, 1600 (CK 1, CK 2, CK 4) Exc. High Ground Clearance sus. (🚗)	96-		333225 L 333224 R		⊕		341140		⊥ ⊕
⊕ High Ground Clearance sus. (🚗) 2WD 1300, 1500, 1600 (CK 1, CK 2, CK 4)	96-				⊕		341145		⊥ ⊕
<b>Lancer Celeste</b> 🚗									
1400, 1600, 2000 (A 72, 73, 78)	75- 80	665020	365004		⊥	443089		553049	⊕ ⊕
<b>Lancer Estate</b> 🚗									
1200, 1400 (A 75 V, 72 V)	1.73- 8.76	663023			⊥	443089			⊕ ⊕
1200, 1400 (A72V, 75V, 141V, 142V, 148V, 149V)	11.76- 79	663024	363020		⊥	443066	343121		⊕ ⊕

\*Excel-G is a new name of SUPER  
 Excel-G ist der neue Name für SUPER  
 Excel-G est le nom nouveau pour SUPER

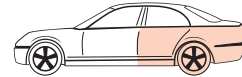
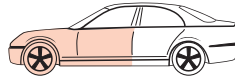

MODEL FAHRZEUG MODELE	YEAR JAHR ANNEE	FRONT/VORNE/AVANT				REAR/HINTEN/ARRIERE			
		PREMIUM Oil	EXCEL-G* Twin-tube Gas	GAS-A-JUST Mono-tube Gas		PREMIUM Oil	EXCEL-G* Twin-tube Gas	GAS-A-JUST Mono-tube Gas	
<b>Mitsubishi (J)</b>									
<b>Lancer Estate </b>									
 1500 (C 12V), 1800 Diesel (C 14V)	6.85- 5.86	633040	333024		 1,4	443222	343203	551037	 0,8
 1500 (C 12V), 1800 Diesel (C 14V) Exc.  (C 12VLNJPL 6)	6.86- 6.87	633059	333037		 1,4	443222	343203	551037	 0,8
 1500  (C 12VLNJPL 6)	6.86- 6.87	633040	333024		 1,4	443222	343203	551037	 0,8
 1500 (C 12V), 1800 Diesel (C 14V)	7.87- 92	633059	333037		 1,4	443222	343203	551037	 0,8
 1800 (C 37V)	11.86- 92	633105	333078		 1,4	443251	343237		 0,8
 1600, 2000 Diesel (CB 4W, CB 8W) Incl. Height Adjust sus. , High Ground Clearance sus.	6.92-	633148 L 633147 R	333125 L 333124 R			443263	343261		
 1600 (CD 4W)	6.92-	633136 L 633135 R	333123 L 333122 R			443263	343261		
<b>Lancer F </b>									
1200, 1400 (A 150 series) Exc. Turbo	82- 84	665018	365027		 2,6	443087	343176	553048	 0,8
1400 Turbo(A 152)	82- 84	665018	365027		 2,6		343183	553112	 0,8
<b>Pajero/Shogun/Montero</b>									
= 2.6 (L042G, L047G) 2.3 Diesel (L043G, L048G) 2.5 Diesel (L044G, L049G)	1.83- 91 1.83- 4.86 5.86- 91	444067	344119	554061 <u>244036</u>	  0,8	443198	343239	553142 <u>244037</u>	 0,8
= 3.0 (L141G, L146G) 2.5 Diesel (L144G, L149G)	11.88- 91 11.88- 91	444067	344119	554061	  0,8	444101	344116	554068	 0,8
= 2.6 (V12V, V32W) 2.5 D/DT (V14C, V14V, V34V) 2.8 D (V36V)	4.91-	444139	344222	554091	  1,4	443198	343239	553142	 0,8
= 2.4 (V21C, V21W, V41W) 3.0 (V23C, V23W, V43W) 3.5-V6 (V25W, V45W) 2.5 DT (V24C, V24W, V44W) 2.8 DT (V26W, V46W) Exc.	12.90-		344222	554091	  1,4		344223	554092	  1,0

\*Excel-G is a new name of SUPER  
Excel-G ist der neue Name für SUPER  
Excel-G est le nom nouveau pour SUPER





MODEL FAHRZEUG MODELE	YEAR JAHR ANNEE	FRONT/VORNE/AVANT				REAR/HINTEN/ARRIERE			
		PREMIUM Oil	EXCEL-G* Twin-tube Gas	GAS-A-JUST Mono-tube Gas		PREMIUM Oil	EXCEL-G* Twin-tube Gas	GAS-A-JUST Mono-tube Gas	
<b>Mitsubishi (J)</b>									
<b>Pajero/Shogun/Montero</b>									
3.5 (V65W, V75W) 2.5TD (V64W, V74W) 3.2TD (V68W, V78W)	2.00-		341251				344300		
<b>Pajero Pinin</b>									
	99-		334813				343802		
<b>Pajeo Sport</b>									
3.0 (K96W) 2.5TD (K94W)	8.98-		344294				344295		
<b>Santamo</b>									
	99-	634042	334070			443265	343262		
<b>Sigma</b>									
3.0-V6 Exc. ECS () (F 16A)	12.90- 7.96		335017				341134		
3.0-V6 Exc. ECS () (F 07W)	1.93- 7.96		335017				344352		
<b>Space Runner</b>									
1.8, 2.0 TD (N 11W, N 18W)	9.91- 8.99	634042	334070			443265	343262		
1.8 (N21W)	9.91- 8.99	634043	334071			443265	343262		
 2.0 (N63) 2.4 (N64)	8.99- 02		334328 L 334327 R				343387		
<b>Space Star</b>									
1.3 (DG1A) Exc. High ground clearance sus.	6.98-		333281 L 333280 R				341204		
High ground clearance sus. 1.3 (DG1A)	6.98-								
1.8 (DG5A)	6.98-		334248 L 334247 R				341204		

\*Excel-G is a new name of SUPER  
 Excel-G ist der neue Name für SUPER  
 Excel-G est le nom nouveau pour SUPER

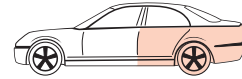
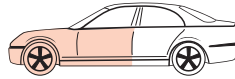

MODEL FAHRZEUG MODELE	YEAR JAHR ANNEE	FRONT/VORNE/AVANT				REAR/HINTEN/ARRIERE			
		PREMIUM Oil	EXCEL-G* Twin-tube Gas	GAS-A-JUST Mono-tube Gas		PREMIUM Oil	EXCEL-G* Twin-tube Gas	GAS-A-JUST Mono-tube Gas	
<b>Mitsubishi (J)</b>									
<b>Space Wagon, Space Van (Chariot), Expo</b>									
1800 (D0 5W, D0 5V), 2000 (D0 4W) 1800 Turbo Diesel (D0 9W, D0 9V)	1.83- 91	634001	334001				343212		
					1,4				0,8
2000 (D0 8W)	3.85- 91	634006	334033				343212		
					1,4				0,8
1.8, 2.0, 2.4, 1.8 TD, 2.0 TD (N31W, N33W, N34W, N35W, N38W)	9.91-	634042	334070			443265	343262		
1.8, 2.0 (N41W, N43W)	9.91-	634043	334071			443265	343262		
2.4 (N84W) 2.4 (N94W)	6.98-		334236 L 334235 R				343312		
<b>Starion</b>									
2000 	(A 182)	5.82- 5.87	665039	365028			343057	553078	
									0,8
2000 Turbo 	(A 183)	5.82- 5.87		365029					
					1,8				
<b>Mitsubishi Commercial (J)</b>									
<b>Canter FB Series</b>									
FB100, FB120	11.80- 85	444148				444157			
FB300	1.86-	444148				444157			
FB431,FB433,FB436	1.86- 96	444149				444157			
FB631	5.96-	441101				444157			
<b>Canter FC Series</b>									
FC432	1.86- 90	444149				444109			
<b>Canter FE Series</b>									
FE100,FE101	11.78- 82	444148				OE = MT116015			

Mitsubishi



MODEL FAHRZEUG MODELE	YEAR JAHR ANNEE	FRONT/VORNE/AVANT				REAR/HINTEN/ARRIERE			
		PREMIUM Oil	EXCEL-G* Twin-tube Gas	GAS-A-JUST Mono-tube Gas		PREMIUM Oil	EXCEL-G* Twin-tube Gas	GAS-A-JUST Mono-tube Gas	
<b>Mitsubishi Commercial (J)</b>									
<b>Canter FE Series</b>									
FE100,FE101	10.82- 85	444148				444157 OE = MB161539,MB161554,MB161556			
FE111	11.78- 82	444148				444109 OE = MT160820			
FE111	11.78- 82	444148				444109 OE = MT160820			
FE111	11.78- 82	444148				OE = MT160854			
FE111 -B,- BD, -BDT, -BZE, - BZEC FE114 -B, -BD, -BDT, -BG	10.82- 85	444148				444157 OE=MB161539,MB161554, MB161556			
FE111 -BG, -BN, -BN1, -BNFW FE114 -BN, -BNFW,-BDN3, -BDN3K	10.82- 85	444148				OE = MB1161553			
FE111 -BZ, -BZ1, -BZB FE111 - E, -EW, -EZ, -EZC, -EZCW FE114 -BZ, -E, -EW, -EZ ,-EZC, -EZCW	10.82- 85	444148				444109 OE = MB161555			
FE120, FE121	11.78- 85	444148				444157			
FE131, FE134	11.78- 85	444148				444109			
FE211, FE214, FE231, FE234	11.78- 85	444149				444109			
FE221, FE224	2.80- 85	444149				444157			
FE331	1.86- 96	444148				444109			
FE431, FE441, FE444	1.86- 96	444149				444109			
FE531	5.96-	444149				444109			
FE649	5.96-	444148				444109			

\*Excel-G is a new name of SUPER  
 Excel-G ist der neue Name für SUPER  
 Excel-G est le nom nouveau pour SUPER

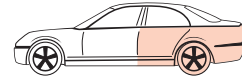
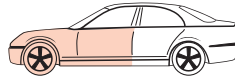

MODEL FAHRZEUG MODELE	YEAR JAHR ANNEE	FRONT/VORNE/AVANT				REAR/HINTEN/ARRIERE			
		PREMIUM Oil	EXCEL-G* Twin-tube Gas	GAS-A-JUST Mono-tube Gas		PREMIUM Oil	EXCEL-G* Twin-tube Gas	GAS-A-JUST Mono-tube Gas	
<b>Mitsubishi Commercial (J)</b>									
<b>Canter FH Series</b>									
FH100	2.88-	444149							
<b>Delica, T Series</b>									
T 100/T 100 V/T120/T 120 V/T 121 Series	68- 6.79	444022		554046				553116 <sup>1)</sup> 553106 <sup>2)</sup>	
<b>L 200</b>									
 (LO 21P/22 P)	6.78- 86	443189	343202	553115		443292	343293	553114	
 (LO 22 G)	10.80- 86	443195		553102		443290	343292	553103	
 1600 (K 11 T) 2000 (K 12 T) 2500 Diesel (K 14 T)	4.87-10.96 11.86-10.96 11.86-10.96	443189	343202	553115		443292	343293	553114	
 2000 (K 22 T/K 32 T) 2600 (K 33 T) 2500 Diesel (K 24 T/K 34 T)	11.86-10.96 12.89-10.96 1.88-10.96	444117	344221	554074		443290	343292	553103	
 2000 (K 62T) 2500 Diesel (K 64T)	1.96-		344389			443292	343293	553227	
 2400 (K 75T) 2500 Diesel (K 74T)	1.96-	444150		554105		443290	343292	553222	
<b>L 300/Delica</b>									
 1.6 (L032P, L062P) 2.3 D (L038P, L068P)	6.79- 5.86	444022		554046		443149 443150 <sup>3)</sup>	343213	553116 553143 <sup>3)</sup>	
 1.6 (L032P), 2.3 D(L038P)	6.79- 5.86	444022		554046		443089			
 1.8 (L035G), 2.0 (L037G)	83- 5.86	444068				443197			
 1.4 (P01W), 1.6 (P02V, P12W/V), 2.0 (P03W/V, P13V), 2.4 (P04W/V, P14V) 2.5 D (P05W/V, P15W/V)	6.86-	444089	344064	554062		443223	343200	553146	
1) O.E. = MT 141620, MA 410923B, A 410923, MB 003595, MB 515566 2) O.E. = MT 141622 3) OE= MB 515568									

Mitsubishi



MODEL FAHRZEUG MODELE	YEAR JAHR ANNEE	FRONT/VORNE/AVANT				REAR/HINTEN/ARRIERE			
		PREMIUM Oil	EXCEL-G* Twin-tube Gas	GAS-A-JUST Mono-tube Gas		PREMIUM Oil	EXCEL-G* Twin-tube Gas	GAS-A-JUST Mono-tube Gas	
<b>Mitsubishi Commercial (J)</b>									
<b>L 300/Delica</b>									
2.0 (P23W, P23V), 2.4 (P24W, P24V) 2.5 D (P25W, P25V), 2.5 DT (P45V)	6.86-	444090	344111			443224	343226		
1.6 (L032P), 2.5 D(L039P)	6.86- 5.94	444022		554046		443150		553143	
2.0 (P 13T), 2.5 DT (P15T)	6.94-	444137		554102		443149	343213	553116	
<b>Space Gear, L 400</b>									
2.0, 2.4, 2.5 DT (PA3W, PA4W, PA5W)	12.94-	444137		554102		443283		553210	
2.0, 2.5 DT (PA3V/5V, PB3V/5V)	12.94-	444137		554102		443285		553193	
2.4, 2.5 DT (PD4W, PD5W)	12.94-	444138		554103		443284		553211	
2.4, 2.5 DT (PD4V, PD5V)	12.94-	444138		554103		443286		553212	
<b>Moskwitch (RUS)</b>									
<b>2141</b>									
2141	87-		366011 <sup>1)</sup> 365800 <sup>2)</sup>				344277		
<p>1) </p> <p>2) </p>									

\*Excel-G is a new name of SUPER  
 Excel-G ist der neue Name für SUPER  
 Excel-G est le nom nouveau pour SUPER

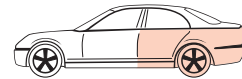
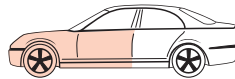

MODEL FAHRZEUG MODELE	YEAR JAHR ANNEE	FRONT/VORNE/AVANT				REAR/HINTEN/ARRIERE			
		PREMIUM Oil	EXCEL-G* Twin-tube Gas	GAS-A-JUST Mono-tube Gas		PREMIUM Oil	EXCEL-G* Twin-tube Gas	GAS-A-JUST Mono-tube Gas	
<b>Nissan (J)</b>									
<b>100 NX </b>									
⊖ ABS 1600	(B13)	10.90- 2.94	633116 L 633115 R	333090 L 333089 R  <u>323033 L</u> <u>323032 R</u>		⊕ 1,9	634037 L <sup>1)</sup> 634036 R <sup>1)</sup>	334046 L <sup>1)</sup> 334045 R <sup>1)</sup>  <u>324006 L<sup>1)</sup></u> <u>324005 R<sup>1)</sup></u>	⊕ 1,0
				SM2800					
⊖ ABS 1600	(B13)	3.94- 95	633116 L 633115 R	333090 L 333089 R  <u>323033 L</u> <u>323032 R</u>		⊕ 1,9	632073 L <sup>2)</sup> 632072 R <sup>2)</sup>	332057 L <sup>2)</sup> 332056 R <sup>2)</sup>  <u>322027 L<sup>2)</sup></u> <u>322026 R<sup>2)</sup></u>	⊕ 1,0
				SM2800					
1600 ⊕ ABS	(B13)	10.90- 95	633116 L 633115 R	333090 L 333089 R  <u>323033 L</u> <u>323032 R</u>		⊕ 1,9	634039 L 634038 R	334048 L 334047 R  <u>324009 L</u> <u>324008 R</u>	⊕ 1,0
				SM2800					
2000 ⊖ ABS, ⊕ ABS	(B13)	10.90- 95	633116 L 633115 R	333090 L 333089 R  <u>323033 L</u> <u>323032 R</u>		⊕ 1,9	634039 L 634038 R	334048 L 334047 R  <u>324009 L</u> <u>324008 R</u>	⊕ 1,0
				SM2800					
<b>200 SX</b>									
1.8 -16V Turbo	(S13)	9.88- 94		331005 L 331003 R		⊕		341099	⊖
2.0 -16V Turbo	(S14)	94-		334185 L 334184 R		⊕		341222	⊖
<b>Almera (N15) </b>									
<sup>2WD</sup> Incl. ⊕ ABS 1.4, 1.6, 2.0 GTI, 2.0 Diesel	(N 15)	7.95- 7.97		333193 L <sup>3)</sup> 333192 R <sup>3)</sup>		⊕		341186 <sup>5)</sup>	⊖
<sup>2WD</sup> Incl. ⊕ ABS 1.4, 1.6, 2.0 GTI, 2.0 Diesel	(N 15)	8.97-12.99		333239 L <sup>4)</sup> 333238 R <sup>4)</sup>		⊕		341226 <sup>6)</sup>	⊖
<div style="display: flex; justify-content: space-around;"> <div style="text-align: center;">1) </div> <div style="text-align: center;">2) </div> <div style="text-align: center;">3) </div> <div style="text-align: center;">4) </div> <div style="text-align: center;">5) </div> <div style="text-align: center;">6) </div> </div>									
<b>Almera (N16E) </b>									
1.5, 1.8, 2.2Di	(N16E)	1.00- 7.00		333309 L 333308 R		⊕		341282	⊖



MODEL FAHRZEUG MODELE	YEAR JAHR ANNEE	FRONT/VORNE/AVANT				REAR/HINTEN/ARRIERE			
		PREMIUM Oil	EXCEL-G* Twin-tube Gas	GAS-A-JUST Mono-tube Gas		PREMIUM Oil	EXCEL-G* Twin-tube Gas	GAS-A-JUST Mono-tube Gas	
<b>Nissan (J)</b>									
<b>Almera (N16E)</b>									
(N16E) 1.5, 1.8, 2.2Di	8.00-		333311 L 333310 R			341282			
<b>Almera (N16)</b>									
1.5, 1.8, 2.2Di (N16)	4.00- 7.00		333309 L 333308 R			341279			
1.5, 1.8, 2.2Di (N16)	8.00- 2.01		333311 L 333310 R			341279			
1.5, 1.8, 2.2Di (N16)	3.01-		333311 L 333310 R			341282			
<b>Almera Tino (V10)</b>									
1.8 (V10)	5.00-10.00		333323 L 333322 R			341283			
1.8 (V10)	11.00-		333327 L 333326 R			341283			
2.0 (V10)	5.00-		333325 L 333324 R			341283			
2.2Di (V10)	5.00-		333323 L 333322 R			341283			
<b>Bluebird, Bluebird U</b>									
(510, P 510, KP 510) 1300, 1600	8.67- 6.70	665011 <sup>1)</sup>	365012 <sup>1)</sup>			444003		553027	
(P/KP 510, H/KH510, N510) 1300, 1400 GX, 1600, 1600 SSS, 1800 SSS	5.71- 8.72	665012 <sup>2)</sup>	365019 <sup>2)</sup>			444003		553027	
(JN 510, JP 510) 1600, 1800	5.71-12.72	665012 <sup>2)</sup>	365019 <sup>2)</sup>			443068	343059		
(V 510, W 510) 1300, 1600	5.71- 8.72	665012 <sup>2)</sup>	365019 <sup>2)</sup>			443072			
<p> <sup>1)</sup> 665011, 365012 : a=27.0 cm  <sup>2)</sup> 665012, 365019 : a=28.0 cm         </p>									

\*Excel-G is a new name of SUPER  
 Excel-G ist der neue Name für SUPER  
 Excel-G est le nom nouveau pour SUPER

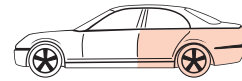
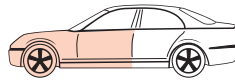

MODEL FAHRZEUG MODELE	YEAR JAHR ANNEE	FRONT/VORNE/AVANT				REAR/HINTEN/ARRIERE			
		PREMIUM Oil	EXCEL-G* Twin-tube Gas	GAS-A-JUST Mono-tube Gas		PREMIUM Oil	EXCEL-G* Twin-tube Gas	GAS-A-JUST Mono-tube Gas	
<b>Nissan (J)</b>									
<b>Bluebird, Bluebird U</b>									
(P 810, P 811) 180 B, 200 B	7.76-10.79	665011	365012				341012	551008	
(J 910, PJ 910, YJ 910) 160 B, 180 B	11.79- 9.83	664003	364003					551007	
(P910, Y910, L910) 160 B, 180 B, 200 B	11.79- 9.83	665014	365011				341012	551008	
(WJ 910) 180 B	11.79-12.81	665014	365011			443158	343123		
(WJ 910) 180 B	1.82- 9.83	665014	365011			443285		553193	
(VJ 910) 180 B Diesel	11.79- 9.83	664003	364003			443158	343123		
180 B (EJ 910) Turbo Diesel	12.82- 9.83	664003	364003						
(U 11) 1800, 1800 Turbo, 2000	11.83- 1.86	634013 L <sup>1)</sup> 634012 R <sup>1)</sup>	334009 L <sup>1)</sup> 334008 R <sup>1)</sup>			664016 <sup>2)</sup>	364020 <sup>2)</sup>		
(U 11) 2000 Diesel, 2000 Diesel Turbo	11.83- 1.86	634017 L <sup>3)</sup> 634016 R <sup>3)</sup>	334011 L <sup>3)</sup> 334010 R <sup>3)</sup>			664016 <sup>2)</sup>	364020 <sup>2)</sup>		
(U 11) 2000i	1.86- 90	634028 L <sup>4)</sup> 634027 R <sup>4)</sup>	334038 L <sup>4)</sup> 334037 R <sup>4)</sup>			664020 <sup>5)</sup>	364022 <sup>5)</sup>		
(U 11) 2000 Diesel	1.86- 90	634082 L <sup>6)</sup> 634081 R <sup>6)</sup>	334060 L <sup>6)</sup> 334059 R <sup>6)</sup>			664020 <sup>5)</sup>	364022 <sup>5)</sup>		
(YU 11, KYU 11, KU 11, RU 11)	10.83- 1.85	633043 L <sup>7)</sup> 633042 R <sup>7)</sup>							
(VRU 11, VEU 11)	10.83- 1.86	633043 L <sup>7)</sup> 633042 R <sup>7)</sup>				443218 <sup>8)</sup>			
(T 12: ) 1600, 1800, 2000 Exc. 1800 Turbo,	12.85- 2.90		334038 L 334037 R			664020	364022		

1) 634012, 334008: O.E. = 54302-13E25/-24E25/-10E25  
634013, 334009: O.E. = 54303-13E25/-24E25/-10E25

2) 664016, 364020: O.E. = 55302/03-10E26/-10E29/-11E25/-11E27/-10E25

3) 634016, 334010: O.E. = 54302-14E26/-05E25  
634017, 334011: O.E. = 54303-14E26/-05E25

4) 634027, 334037: O.E. = 54302-24E26  
634028, 334038: O.E. = 54303-24E26

5) 664020, 364022: O.E. = 55302/03-D4027, 56205-D4027/-D4126

6) 634081, 334059: O.E. = 54302-14E27  
634082, 334060: O.E. = 54303-14E27

7) 633042 : O.E. = 54302-01E25/-04E25  
633043 : O.E. = 54303-01E25/-04E25

8) 443218 : O.E. = 56210-09E25/-11E25





MODEL FAHRZEUG MODELE	YEAR JAHR ANNEE	FRONT/VORNE/AVANT				REAR/HINTEN/ARRIERE			
		PREMIUM Oil	EXCEL-G* Twin-tube Gas	GAS-A-JUST Mono-tube Gas		PREMIUM Oil	EXCEL-G* Twin-tube Gas	GAS-A-JUST Mono-tube Gas	
<b>Nissan (J)</b>									
<b>Bluebird, Bluebird U</b>									
(T 12: ) 2000 Diesel	12.85- 2.90		334060 L 334059 R			664020	364022		
					1,9				3,0
(T 72: ) 1600, 1800, 2000 Exc. 1800 Turbo,	7.86- 4.90		334038 L 334037 R			664020	364022		
					1,9				3,0
(T 72: ) 2000 Diesel	7.86- 4.90		334060 L 334059 R			664020	364022		
					1,9				3,0
<b>Cedric &amp; Gloria</b>									
(430) 200 C, 220 C, 240 C, 260 C, 280 C, 220 D Exc. 2000 Turbo	3.79- 9.83	444038	344006	553037		441008	341011	551010	
(430) 2000 Turbo	3.79- 9.83		344006	553037			341011	551010	
(W 430) 200 C, 220 D, 280 C	3.79- 9.83	444038	344006	553037		444011	344013	554023	
(NY 30, HY 30, KNY 30) 2000, 2800 Diesel	10.83-	665054	365045			444081	344104	554050	
(PY 30, KPY 30) 3000	10.83-	665053	365049			444081	344104	554050	
(WPY 30) 3000	10.83-	665054	365045			444011	344013	554023	
<b>Cherry, Pulsar</b>									
100 A, 120 A (E10) 	9.70- 9.74	662005						552001	
100 AF II, 120 AF II (F 10, 11) 	9.74- 7.78	662001	362002					552001	
					3,0				0,9
120 A, 140 A (N10) 	4.78- 5.82	662001	362002					552001	
					3,0				0,9
(N 12) Exc. 1500 Turbo, Cherry Europe (Alfa 33 sus.)	5.82- 5.86	632013 L 632012 R	332006 L 332005 R			442035	342008	552010	
					1,9				0,9
(N 13) Exc. , 1800-16V	6.86- 9.90	632041 L 632040 R	332029 L 332028 R  322025 L 322024 R			632047 L 632046 R	332027 L 332026 R  322023 L 322022 R		
					2,7				1,6

\*Excel-G is a new name of SUPER  
Excel-G ist der neue Name für SUPER  
Excel-G est le nom nouveau pour SUPER

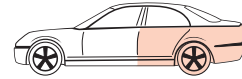
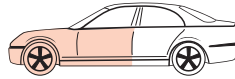

MODEL FAHRZEUG MODELE	YEAR JAHR ANNEE	FRONT/VORNE/AVANT				REAR/HINTEN/ARRIERE			
		PREMIUM Oil	EXCEL-G* Twin-tube Gas	GAS-A-JUST Mono-tube Gas		PREMIUM Oil	EXCEL-G* Twin-tube Gas	GAS-A-JUST Mono-tube Gas	
<b>Nissan (J)</b>									
<b>Cherry, Pulsar</b>									
(4WD) (NN13) 1600	6.86- 9.90		332039 L 332038 R				333054 L 333053 R		
					2,9				0,9
<b>Fair Lady, 280 ZX, 300 ZX</b>									
Z, 280 ZX Incl. 2+2 (S 130)	10.78-12.80		365013				341012	551008	
					3,8				
Z, 280 ZX Incl. 2+2 (S 130)	1.81- 9.81		365013					551007	
					3,8				
Z, 280 ZX Incl. 2+2 (S 130)	10.81- 9.83	665043	365031					551031	
					3,8				
3.0, 3.0 Turbo Exc.	(Z31) 10.81- 89		365098					554104	
3.0 Turbo (Z32)	1.90-		OE =				OE =		
<b>Junior</b>									
Junior (140, N 140)	70-	444063				444026			
<b>Laurel</b>									
(C 230, C 231) 180 L, 200 L, 240 L, 260 L	1.77-10.80	665011	365012				341012	551008	
					3,8				
(C 31) 1.8, 2.0, 2.4, 2.8 Diesel Exc. , 2.0 Turbo	11.80-10.84	665011	365012				341031	551028	
					3,8				
(C 31) 2.0 Turbo Exc.	11.80-10.84		365012					551028	
					3,8				
(C 32) 2.0, 2.4 E, 2.8 Diesel	11.84- 2.90	665058	365073				341052		
					3,8				
(C 32) 2.4, 3.0 Exc.	3.86-	665058	365073				341051		
					3,8				
(C 32) 2.4, 3.0 	3.86-	665058	365073						
					3,8				

\*Excel-G is a new name of SUPER  
Excel-G ist der neue Name für SUPER  
Excel-G est le nom nouveau pour SUPER



MODEL FAHRZEUG MODELE	YEAR JAHR ANNEE	FRONT/VORNE/AVANT				REAR/HINTEN/ARRIERE			
		PREMIUM Oil	EXCEL-G* Twin-tube Gas	GAS-A-JUST Mono-tube Gas		PREMIUM Oil	EXCEL-G* Twin-tube Gas	GAS-A-JUST Mono-tube Gas	
<b>Nissan (J)</b>									
<b>Maxima</b>									
(J 30) Incl. ⊕ ABS	12.88-10.94		334159 L 334158 R		⊕		365079		⊐
(A 32)	10.94-		334151 L 334150 R		⊕		341202		⊐
<b>Micra, March</b>									
(K10) Exc. Turbo	12.82-11.92	632011 L 632078 R	332025 L 332060 R		⊕ 1,7	441043	341056		⊐ 0,8
(K11)	8.92-12.02	632080 L 632079 R	332062 L 332061 R		⊕ 2,4	443255	343249		⊐ 2,0
(K12)	1.03-		333722 L 333721 R		⊕		343807		⊐
<b>Pathfinder </b>									
3300i (R50)	10.97- 1.99	635012 L 635011 R	335023 L 335022 R		⊕	443294		553229	⊐
3300i (R50)	2.99-		335031 L 335030 R		⊕	443363		553303	⊐
<b>Patrol/Safari</b>									
Hardtop (  ) (TR *160, KR *160, KM *160)	6.80- 7.82	443153		554034	⊐ 0,7	443154		554035	⊐ 0,7
Wagon (  ) (WR *160, WM *160, CR *160)	6.80- 7.82	443153		554034	⊐ 0,7	443155		554036	⊐ 0,7
(  ) Wagon (WR *160, WM*160, CR*160) Hardtop (TR *160, KR *160, KM *160)	8.82- 8.88	444052		554037	⊐ 0,7	444053		554038	⊐ 0,7
(  ) (UR *160) Exc. H/D	7.81- 6.82			554034	⊐ 0,7			554036 <sup>1)</sup>	⊐ 0,7
							Lmax = 517 mm		
(  ) (UR *160) ⊕ H/D	7.81- 6.82			554034	⊐ 0,7			554038 <sup>1)</sup>	⊐ 0,7
							Lmax = 537 mm		
1)									

\* Excel-G is a new name of SUPER  
 Excel-G ist der neue Name für SUPER  
 Excel-G est le nom nouveau pour SUPER

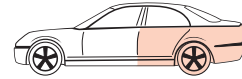
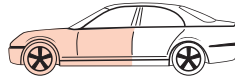

MODEL FAHRZEUG MODELE	YEAR JAHR ANNEE	FRONT/VORNE/AVANT				REAR/HINTEN/ARRIERE			
		PREMIUM Oil	EXCEL-G* Twin-tube Gas	GAS-A-JUST Mono-tube Gas		PREMIUM Oil	EXCEL-G* Twin-tube Gas	GAS-A-JUST Mono-tube Gas	
<b>Nissan (J)</b>									
<b>Patrol/Safari</b>									
(UR *160) Exc. H/D	7.82- 9.85			554037	$\frac{\perp}{\ominus}$ 0,7			554036 <sup>1)</sup>	$\frac{\circ}{\top}$ 0,7
(UR *160) ⊕ H/D	7.82- 9.85			554037	$\frac{\perp}{\ominus}$ 0,7			554038 <sup>1)</sup>	$\frac{\circ}{\top}$ 0,7
260 () 2.8 Diesel/Turbo Diesel 3.0 Exc. Hardtop high(Armoured)(GY 260)	3.89- 3.89-	444129		554096	$\frac{\perp}{\ominus}$ 0,6	444130		554097	$\frac{\circ}{\circ}$ 0,7
Y 60 () 2.8 Turbo Diesel 4.2	9.88- 10.91-		344107	554093	$\frac{\perp}{\ominus}$ 0,5		345007	555006	$\frac{\circ}{\oplus}$ 0,7
Y 61 () 2.8 Turbo Diesel	10.97-	444159		554112	$\frac{\perp}{\ominus}$	444160		554113	$\frac{\circ}{\oplus}$

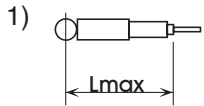

**Pick-up, Cab, King Cab**

(520, 521, 620 series)	65- 78	443078			$\frac{\perp}{\oplus}$ 2,4	443079		553096	$\frac{\circ}{\top}$ 0,7
(720 series)	10.79- 8.85	443080		553088	$\frac{\perp}{\oplus}$ 2,4	443079		553096	$\frac{\circ}{\top}$ 0,7
(720 series)	10.79-12.81	443227		553088	$\frac{\perp}{\oplus}$ 2,4	443079		553098	$\frac{\circ}{\top}$ 0,7
(720 series)	1.82- 7.85	443227		553088	$\frac{\perp}{\oplus}$ 2,4	443179	343214	553120	$\frac{\circ}{\circ}$ 0,7
(GD 21)	9.85- 2.98	443238		553159	$\frac{\perp}{\circ}$ 2,4	443226		553154	$\frac{\circ}{\circ}$ 0,7
(MD 21)	9.85- 2.98	443239		553152 <u>243024</u>	$\frac{\perp}{\oplus}$ 2,4	443240		553153 <u>243025</u>	$\frac{\circ}{\circ}$ 0,7
(D 22)	2.98-	443238		553159	$\frac{\perp}{\circ}$	443226		553154	$\frac{\circ}{\circ}$
(D 22)	2.98-	443293		553228	$\frac{\perp}{\oplus}$	443240		553153	$\frac{\circ}{\circ}$

\*Excel-G is a new name of SUPER  
Excel-G ist der neue Name für SUPER  
Excel-G est le nom nouveau pour SUPER



MODEL FAHRZEUG MODELE	YEAR JAHR ANNEE	FRONT/VORNE/AVANT				REAR/HINTEN/ARRIERE			
		PREMIUM Oil	EXCEL-G* Twin-tube Gas	GAS-A-JUST Mono-tube Gas		PREMIUM Oil	EXCEL-G* Twin-tube Gas	GAS-A-JUST Mono-tube Gas	
<b>Nissan (J)</b>									
<b>Prairie</b>									
(BM 10, PM 10) 1500, 1800	8.82- 8.88	633047 L 633046 R	333035 L 333034 R		 2,9	443212	343225		 1,0
(M11) 2000, 2400	10.88- 7.94		334161 L 334160 R				363065		
(NM11) 2000, 2400	10.88- 7.94		334161 L 334160 R						
<b>Primera </b>									
(P10) 1.6, 2.0 Diesel	6.90- 96		341120		 3,8		333104 L▼ 333103 R▼  333283 L 333282 R		 2,2
(P10) 1.6, 2.0 Diesel	6.90- 96		341120		 3,8		333283 L 333282 R		 2,2
(P10) 2000 (  =  ) Incl.	6.90- 96		341120 351013		 3,8		334057 L 334056 R  324011 L 324010 R		 2,2
1.6, 2.0, 2.0 Diesel Turbo Exc. 2.0 SRI, 2.0 GTI	(P11) 6.96- 01		341120				341227		
2.0 SRI, 2.0 GTI	(P11) 6.96- 01		341120				341228		
(P12) 1.02-			◇ 331015 L 331014 R ◇				◇ 341325		
<b>Primera </b>									
1.6, 2.0, 2.0 Diesel	(W 10) 7.90- 1.98		332064 L 332063 R		 3,0		343248		 2,1
1.6, 2.0, 2.0 Diesel Turbo Incl. 2.0 SRI	(WP 11) 1.98- 01		341120				341228		
(WP 12) 1.02-			◇ 331015 L 331014 R ◇				◇ 341325		

\*Excel-G is a new name of SUPER  
Excel-G ist der neue Name für SUPER  
Excel-G est le nom nouveau pour SUPER

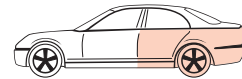
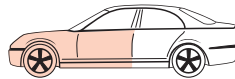

MODEL FAHRZEUG MODELE	YEAR JAHR ANNEE	FRONT/VORNE/AVANT				REAR/HINTEN/ARRIERE			
		PREMIUM Oil	EXCEL-G* Twin-tube Gas	GAS-A-JUST Mono-tube Gas		PREMIUM Oil	EXCEL-G* Twin-tube Gas	GAS-A-JUST Mono-tube Gas	
<b>Nissan (J)</b>									
<b>Serena</b>									
(C23) 1.6 2.0 Diesel  Exc. SGX	7.92- 7.92-10.95	634075 L 634074 R	334143 L 334142 R			443149	343213	553116	
SM2800									
(C23) 2.3 Diesel  Exc. SGX	11.95-	634075 L 634074 R	334143 L 334142 R			443149	343213	553116	
Incl.  (C23) 2.0 Diesel SGX	7.92-10.95	634075 L 634074 R	334143 L 334142 R			444131		554098	
SM2800									
Incl.  (C23) 2.3 Diesel SGX	11.95- 5.96	634075 L 634074 R	334143 L 334142 R			444131		554098	
(C23) 2.0 (  =  ) SLX , SGX Incl.	7.92- 5.96	634075 L 634074 R	334143 L 334142 R			444131 <sup>1)</sup>		554098 <sup>1)</sup>	
SM2800									
(C23) 2.0 (  =  ) SE Incl.	6.96- 00	634075 L 634074 R	334143 L 334142 R			444158 <sup>1)</sup>		554111 <sup>1)</sup>	
SM2800									
1)									
<b>Silvia</b>									
(S12)	10.83- 5.88		365013				343210		
<b>Skyline Exc. </b>									
(C 211 series) 160 K, 180 K, 200 K, 240 K, 280 D	8.77- 7.81	665011	365012				341012	551008	
3,8									
(R 30) 1800, 2000, 2800 Diesel Exc. 2000 Turbo	8.81-7.85	665011	365012				341031	551028	
3,8									
(R 30) 2000 Turbo	8.81- 7.85		365012					551028	
3,8									
(VR 30) 1800, 2000	8.81-	665011	365012						
3,8									



MODEL FAHRZEUG MODELE	YEAR JAHR ANNEE	FRONT/VORNE/AVANT			⌚	REAR/HINTEN/ARRIERE			⌚
		PREMIUM Oil	EXCEL-G* Twin-tube Gas	GAS-A-JUST Mono-tube Gas		PREMIUM Oil	EXCEL-G* Twin-tube Gas	GAS-A-JUST Mono-tube Gas	
<b>Nissan (J)</b>									
<b>Sunny</b>									
120 Y Exc.	(B 210, 211)	5.73-10.77		362001				552003	⊥ ⊕
120 Y Exc.	(KB 210, 211)	5.73-10.77		362001				552005	⊥ ○
120 Y 	(B 210)	2.76- 7.78	664002					552003	⊥ ⊕
120 Y 	(KB 210)	2.76- 7.78	664002					552005	⊥ ○
120Y	(B 310)	9.78- 81	664002				442008	342005	553023 ⊥ ⊕ 0,6
140Y  (HB310, KHB310) 150Y  (PB310, KPB310)		10.77-10.80 11.80- 9.81	664002				442008	342005	553023 ⊥ ⊕ 0,6
1300, 1500 Exc. Turbo	(B 11)	10.81- 9.85	632009 L 632008 R	332008 L 332007 R			442035	342008	552010 ⊥ ⊕ 0,9
1700 Diesel 	(B 11)	10.82- 5.86	633047 L 633046 R	333035 L 333034 R			442035	342008	552010 ⊥ ⊕ 0,9
1500 Turbo 	(B 11)	9.82- 5.86	633047 L 633046 R	333035 L 333034 R					552010 ⊥ ⊕ 0,9
Exc. , 1800-16V	(B 12, N13)	6.86- 9.90	632041 L 632040 R	332029 L 332028 R  322025 L 322024 R			632047 L 632046 R	332027 L 332026 R  322023 L 322022 R	 1,6
 1600	(NN13)	6.86- 9.90		332039 L 332038 R				333054 L 333053 R	 0,9
ABS 1400 2000 Diesel	(N14)	10.90- 95	633116 L 633115 R	333090 L 333089 R  323033 L 323032 R			632073 L 632072 R	332057 L 332056 R  322027 L 322026 R	 2,8

\*Excel-G is a new name of SUPER  
Excel-G ist der neue Name für SUPER  
Excel-G est le nom nouveau pour SUPER

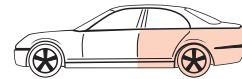
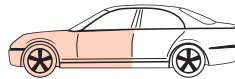

MODEL FAHRZEUG MODELE	YEAR JAHR ANNEE	FRONT/VORNE/AVANT				REAR/HINTEN/ARRIERE			
		PREMIUM Oil	EXCEL-G* Twin-tube Gas	GAS-A-JUST Mono-tube Gas		PREMIUM Oil	EXCEL-G* Twin-tube Gas	GAS-A-JUST Mono-tube Gas	
<b>Nissan (J)</b>									
<b>Sunny</b>									
(2WD) ⊖ ABS 1600 (N14)	10.90-10.93	633116 L 633115 R	333090 L 333089 R <u>323033 L</u> <u>323032 R</u>		⊕ 2,9	634037 L <sup>1)</sup> 634036 R <sup>1)</sup>	334046 L <sup>1)</sup> 334045 R <sup>1)</sup> <u>324006 L<sup>1)</sup></u> <u>324005 R<sup>1)</sup></u>		⊕ 2,8
(2WD) ⊖ ABS 1600 (N14)	11.93- 95	633116 L 633115 R	333090 L 333089 R <u>323033 L</u> <u>323032 R</u>		⊕ 2,9	632073 L <sup>2)</sup> 632072 R <sup>2)</sup>	332057 L <sup>2)</sup> 332056 R <sup>2)</sup> <u>322027 L<sup>2)</sup></u> <u>322026 R<sup>2)</sup></u>		⊕ 2,8
(2WD) ⊕ ABS 1400 1600 2000 Diesel (N14)	10.90- 95	633116 L 633115 R	333090 L 333089 R <u>323033 L</u> <u>323032 R</u>		⊕ 2,9	634039 L 634038 R	334048 L 334047 R <u>324009 L</u> <u>324008 R</u>		⊕ 2,8
(2WD) 2000 (  =  ) Incl. ⊕ ABS Exc. GTI -R (2000 Turbo (4WD) : NN14) (N14)	10.90- 95	633116 L 633115 R	333090 L 333089 R <u>323033 L</u> <u>323032 R</u>		⊕ 2,9	634039 L 634038 R	334048 L 334047 R <u>324009 L</u> <u>324008 R</u>		⊕ 2,8
(4WD) 1600 (NN14)	10.90- 95	633120 L 633119 R	333092 L 333091 R		⊕ 2,9	632071 L 632070 R	332059 L 332058 R		⊕ 2,8
1)  Ø 51 mm 2)  Ø 45 mm									
<b>Sunny Excellent</b>									
1400 (PB 110)	7.71- 5.73	665011	365012		□			552003	⊥ ⊖
1400 (KPB 110)	7.71- 5.73	665011	365012		□		343194		⊥ ○
1400 (PB 210)	5.73- 2.76	664003	364003		□			552003	⊥ ⊖
1400 (KPB 210, KGB 211)	5.73-12.76	664003	364003		□			552005	⊥ ○





MODEL FAHRZEUG MODELE	YEAR JAHR ANNEE	FRONT/VORNE/AVANT			⌚	REAR/HINTEN/ARRIERE			⌚
		PREMIUM Oil	EXCEL-G* Twin-tube Gas	GAS-A-JUST Mono-tube Gas		PREMIUM Oil	EXCEL-G* Twin-tube Gas	GAS-A-JUST Mono-tube Gas	
<b>Nissan (J)</b>									
<b>Sunny, Sunny Traveller</b>									
1000 (VB 10, B 20) 	4.66-12.69	442004			⊖ ⊕	443065			⊥ ○
1200 (VB 110, B 120) 	1.70- 5.73		362001		□	443066	343121		○ ○
120Y (VB 210) Exc.	5.73-10.77		362001		□	443066	343121		○ ○
120Y (VB 210) 	2.76- 7.78	664002			□	443066	343121	553083	○ ○
140Y   (VB 310) Exc.	10.77- 9.81		362001		□	443066	343121		○ ○
140Y   (VB 310) 	10.77- 9.81	664002			□	443066	343121		○ ○
140Y   (WHB310) 150Y   (WPB310)	10.77-10.80 11.80- 9.81	664002			□ 3,8	442008	342005	553023	⊥ ⊖ 0,6
1300, 1500 (VB11, TB11) 	10.82- 90	632009 L 632008 R	332008 L 332007 R		⊕ 2,9	443229			⊕ ⊖ 0,9
1300, 1500, 1600 (WB 11) 	10.81- 86	632009 L 632008 R	332008 L 332007 R		⊕ 2,9	442035	342008	552010	⊥ ⊖ 0,9
1700 Diesel (WB 11) 	10.81- 86	633047 L 633046 R	333035 L 333034 R		⊕ 2,9	442035	342008	552010	⊥ ⊖ 0,9
 1500, 1600, 1700 Diesel Exc.	(WB 12) 6.86- 9.90	632041 L 632040 R	332029 L 332028 R <u>322025 L</u> <u>322024 R</u>		⊕ 2,9	632047 L 632046 R	332027 L 332026 R <u>322023 L</u> <u>322022 R</u>		⊕ 1,6
 1600 (WNB 12)	6.86- 9.90		332039 L 332038 R		⊕ 2,9		333054 L 333053 R		⊕ 0,9
 1600 (TAYA Y 10) 2000 Diesel (TVCA Y 10)	11.90- 11.90-	633116 L 633115 R	333090 L 333089 R		⊕ 2,9		343240		○ ⊖ 0,9
 1600 (TAYN Y 10)	11.90-	633120 L 633119 R	333092 L 333091 R		⊕ 2,9		343241		⊖ ○ 0,9

\*Excel-G is a new name of SUPER  
 Excel-G ist der neue Name für SUPER  
 Excel-G est le nom nouveau pour SUPER

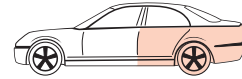
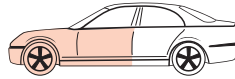

MODEL FAHRZEUG MODELE	YEAR JAHR ANNEE	FRONT/VORNE/AVANT				REAR/HINTEN/ARRIERE				
		PREMIUM Oil	EXCEL-G* Twin-tube Gas	GAS-A-JUST Mono-tube Gas		PREMIUM Oil	EXCEL-G* Twin-tube Gas	GAS-A-JUST Mono-tube Gas		
<b>Nissan (J)</b>										
<b>Terrano </b>										
2400 i (WD21)	8.86-10.87	443253 <sup>1)</sup>	343244 <sup>1)</sup>	553170 <sup>1)</sup>		443183	343245	553111		
					⊥ ⊕ 1,0				○ ○ 0,6	
2400 i, 2700 Turbo Diesel (WD21)	10.87- 93	444102 <sup>1)</sup>	344200 <sup>2)</sup>	554070 <sup>2)</sup>		443183	343245	553111		
					⊥ ⊕ 1,0				○ ○ 0,6	
3000 i Exc.	8.89-	444102	344200	554070		443183	343245	553111		
					⊥ ⊕ 1,0				○ ○ 0,6	
<div style="display: flex; justify-content: space-around;"> <div style="text-align: center;"> <p>1)</p> <p>Ø 39 mm</p> </div> <div style="text-align: center;"> <p>2)</p> <p>Ø 45 mm</p> </div> </div>										
<b>Terrano II </b>										
	(R 20)	93-	444102	344200	554070		443295		553230	
						⊥ ⊕ 1,0				○ ○ 0,6
<b>Violet, Stanza, Auster</b>										
(J 710, J 711)	1.73- 7.77	665012	365019			443068	343059	553025		
140 J, 160 J									⊥ ○	
(P 710, P 711)	1.73- 7.77	665012	365019			444003		553026		
140 J SSS, 160 J SSS									⊥ ○	
140J (V 710)	1.73- 7.77	665012	365019			443069	343122			
									⊕ ○	
140 J, 160 J Incl. SSS (A11)	7.77- 6.81	664003	364003					553023		
					3,8				⊥ ⊕ 0,6	
140J (VA 11)	7.77- 6.81	664003	364003			443070	343060			
					3,8				○ ○	
(T 11)	6.81- 9.85	664011	364004			664012	364005			
					2,8				⊥ 2,5	

\*Excel-G is a new name of SUPER  
Excel-G ist der neue Name für SUPER  
Excel-G est le nom nouveau pour SUPER



MODEL FAHRZEUG MODELE	YEAR JAHR ANNEE	FRONT/VORNE/AVANT				REAR/HINTEN/ARRIERE			
		PREMIUM Oil	EXCEL-G* Twin-tube Gas	GAS-A-JUST Mono-tube Gas		PREMIUM Oil	EXCEL-G* Twin-tube Gas	GAS-A-JUST Mono-tube Gas	
<b>Nissan Commercial (J)</b>									
<b>Clipper, Caball</b>									
Clipper (T 65 series)	66- 71	444060		553025	$\frac{\perp}{\circ}$	444023	344102	553084	$\frac{\circ}{\circ}$
Clipper (660, 661)	2.69- 8.71	444060		553025	$\frac{\perp}{\circ}$				
Clipper (T 662, 663)	4.69- 5.76	444060		553025	$\frac{\perp}{\circ}$				
Caball  (C240, C340) Exc. bus,	68-12.81	444060		553025	$\frac{\perp}{\circ}$	444024			$\frac{\circ}{\circ}$
<b>Homer, Cabstar</b>									
(F 20, F 21 series)	1.76- 3.78	444005		553123	$\frac{\perp}{\circ}$	444025		553058	$\frac{\circ}{\circ}$
(F 20) Exc. low flat floor	4.78- 82	444054			$\frac{\perp}{\ominus}$	444025		553058	$\frac{\circ}{\circ}$
Low flat floor 	(F 20) 10.78- 82	444054			$\frac{\perp}{\ominus}$	444055			$\frac{\circ}{\circ}$
2.0	(F 22) 1.82- 2.89	444054			$\frac{\perp}{\ominus}$	444055 $\langle \text{OE} \rangle = 56210\text{-}T3000\text{-}T6100\text{-}T6210$			$\frac{\circ}{\circ}$
2.0 Exc. Steel High Bed	(F 22) 2.89- 6.92	444054			$\frac{\perp}{\ominus}$	444140 $\langle \text{OE} \rangle = 56210\text{-}22T00$			$\frac{\circ}{\circ}$
2.0 Steel High Bed	(F 22) 2.89- 6.92	444054			$\frac{\perp}{\ominus}$	444055 $\langle \text{OE} \rangle = 56210\text{-}T6210$			$\frac{\circ}{\circ}$
2.3 Diesel Incl. Low flat A-Chassis	(F 22) 1.82- 6.92	444054			$\frac{\perp}{\ominus}$	444055 $\langle \text{OE} \rangle = 56210\text{-}T6100\text{-}T6210$			$\frac{\circ}{\circ}$
2.3 Diesel Exc. Low flat A-Chassis	( F 22) 1.82- 6.92	444054			$\frac{\perp}{\ominus}$	444026 $\langle \text{OE} \rangle = 56210\text{-}T6200\text{-}T6202$			$\frac{\circ}{\circ}$
2.3 Diesel Low flat A-Chassis	(F 22) 1.82- 6.92	444054			$\frac{\perp}{\ominus}$	444055 $\langle \text{OE} \rangle = 56210\text{-}T6210$			$\frac{\circ}{\circ}$
2.5 Diesel Incl. H/D	(F 22) 1.82- 2.89	444054			$\frac{\perp}{\ominus}$	444055 $\langle \text{OE} \rangle = 56210\text{-}T3000\text{-}T6100\text{-}T6210$			$\frac{\circ}{\circ}$
2.5 Diesel Exc. H/D	(F 22) 2.89- 6.92	444054			$\frac{\perp}{\ominus}$	444140 $\langle \text{OE} \rangle = 56210\text{-}22T00$			$\frac{\circ}{\circ}$

\*Excel-G is a new name of SUPER  
 Excel-G ist der neue Name für SUPER  
 Excel-G est le nom nouveau pour SUPER

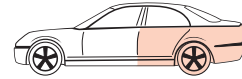
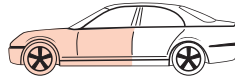

MODEL FAHRZEUG MODELE	YEAR JAHR ANNEE	FRONT/VORNE/AVANT			⚙️ ⌚	REAR/HINTEN/ARRIERE			⚙️ ⌚
		PREMIUM Oil	EXCEL-G* Twin-tube Gas	GAS-A-JUST Mono-tube Gas		PREMIUM Oil	EXCEL-G* Twin-tube Gas	GAS-A-JUST Mono-tube Gas	
<b>Nissan Commercial (J)</b>									
<b>Homer, Cabstar</b>									
2.5 Diesel   (F 22)	2.89- 6.92	444054			⊥ ⊕	444055 ⊕ = 56210-T6210			○ ○
2.5 Diesel   Exc. H/D (F 22)	1.82- 6.92	444054			⊥ ⊕	444026 ⊕ = 56210-T6200/- T6202			○ ○
2.5 Diesel   ⊕ H/D (F 22)	1.82- 6.92	444054			⊥ ⊕	444055 ⊕ = 56210-T6210			○ ○
2.0  (F 23)	7.92-	444054			⊥ ⊕	444140 ⊕ = 56210-22T00			○ ○
2.5 Diesel Exc. Low flat (F 23)	7.92-	444054			⊥ ⊕	444140 ⊕ = 56210-22T00			○ ○
2.5 Diesel Low flat (F 23)	7.92-	444054			⊥ ⊕	444026 ⊕ = 56210-T6202			○ ○
<b>Serena Cargo, Vanette Cargo</b>									
1.6, 2.0 Diesel (C 23)	7.92-	634075 L 634074 R	334143 L 334142 R		⊕	443149	343213	553116	○ ○
				SM2800					
2.3 Diesel (C 23)	7.92-	634075 L 634074 R	334143 L 334142 R		⊕	443149	343213	553116	○ ○
<b>Urvan, Caravan</b>									
(E 20, 22, 23)	4.78-10.86	444039		554047	⊥ ⊕	443079		553095	○ ⊥
(E 24) Exc.  (C 22)	11.86-	444132		554099	⊥ ⊕	444025		554075	○ ○
<b>Vanette, Vanette Cargo</b>									
C120  ()	8.78- 6.87	443187		553099	⊕ ○ 0,7	443184		553100	○ ○ 0,7
C120, C220  ()		443187 ⊕ = 56110 -Y9502		553099	⊕ ○	443184 ⊕ = 56210 -Y9502		553100	○ ○
() (C 22)	9.87-	444118		554072	⊕ ○	443177		553145	○ ○

\*Excel-G is a new name of SUPER  
Excel-G ist der neue Name für SUPER  
Excel-G est le nom nouveau pour SUPER



MODEL FAHRZEUG MODELE	YEAR JAHR ANNEE	FRONT/VORNE/AVANT				REAR/HINTEN/ARRIERE				
		PREMIUM Oil	EXCEL-G* Twin-tube Gas	GAS-A-JUST Mono-tube Gas		PREMIUM Oil	EXCEL-G* Twin-tube Gas	GAS-A-JUST Mono-tube Gas		
<b>Nissan Commercial (J)</b>										
<b>Vanette, Vanette Cargo</b>										
(JPN) (C 22)	9.86-	444118		554072		443279		553202		
<b>Opel (D)</b>										
<b>Agila</b>										
(H00) 1.0, 1.2 Incl.	4.00-		333307 L 333306 R				343331			
<b>Ascona, Manta</b>										
Ascona, L, SR, Voyage Manta, L, SR, GT Manta E Manta CC/CCE/GTE	8.75- 6.81 8.75- 88 9.77- 88 8.78- 88	443026	343048	553009 <u>244029</u>	 0,6	443027	343006	554011 <u>244030</u>	 0,7	
Ascona	8.81- 8.84	665042	365030 		 2,1	443230	343150	551033	 0,6	
Ascona C 1003027 → 5000001 → 6000001 →	9.84- 9.88	665057	365054 		 2,1	443230	343150	551033	 0,6	
<b>Astra</b>										
  Exc. GT, GSi	8.91- 98	665066	365078 375034 		 2,1	443134	343047	553075 <u>243014</u>	 0,6	
GT, GSi 	8.91- 98		365078 375034 		 2,1		343047	553075 <u>243014</u>	 0,6	
 	8.91- 98	665066	365078 		 2,1	443135	343099 Exc.	553137	 0,6	
Astra G   Exc. Sport sus.	(T98) 98-		334949 L 334948 R 				343306	553240		
Astra G  	(T98) 98-		334608 L 334607 R				343306	553240		
Astra G   Exc. Sport sus.	(T98) 98-		334949 L 334948 R 				343307	553241		

\* Excel-G is a new name of SUPER  
Excel-G ist der neue Name für SUPER  
Excel-G est le nom nouveau pour SUPER

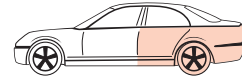
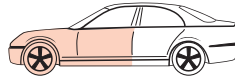

MODEL FAHRZEUG MODELE	YEAR JAHR ANNEE	FRONT/VORNE/AVANT				REAR/HINTEN/ARRIERE			
		PREMIUM Oil	EXCEL-G* Twin-tube Gas	GAS-A-JUST Mono-tube Gas		PREMIUM Oil	EXCEL-G* Twin-tube Gas	GAS-A-JUST Mono-tube Gas	
<b>Opel (D)</b>									
<b>Astra</b>									
Astra G (T98) ⊕ Sport sus.	98-		334608 L 334607 R		⊕		343307	553241	⊖
<b>Calibra</b>									
2.0 i (2WD), (4WD) Exc. 16 V, 16 V Turbo	90- 98	665063	365071 <u>375032</u> 		⊐ 2,2	443261	343259 <u>353011</u>	553182	⊥ ⊖ 0,7
2.0 i-16V (2WD), (4WD) 2.5 i-V6 (2WD)	90- 98		365071 <u>375032</u> 		⊐ 2,2		343259 <u>353011</u>	553182	⊥ ⊖ 0,7
2.0 i-16V Turbo (4WD)	90- 98		365071 <u>375032</u> 		⊐ 2,2		343259 <u>353011</u>	553182	⊥ ⊖ 0,7
<b>Commodore</b>									
Commodore A 2.2, 2.5, Taxi	67- 1.72	443029	343005	553012	⊥ ⊖	443030	343049	554012	⊥ ⊖
Commodore B 2.5, 2.8	9.72- 7.77	443029	343005	553012	⊥ ⊖	443027	343006	554011	⊥ ⊖
Commodore B 2.5, 2.8	9.72- 4.75	443029	343005	553012	⊥ ⊖	443031	343007	554013	⊥ ⊖
Commodore C 2.5 S, 2.5 E	78- 82	665035	365007 		⊐ 2,3	443027	343006	554011	⊥ ⊖ 0,7
<b>Corsa A, Corsa B , </b>									
 Exc. 1.6 GSi	83- 2.93	633831	333831 <u>323034</u> 		⊕ 1,3	443225	343265 <u>353012</u>	553155	⊥ ⊖ 0,6
1.6i GSi	88- 2.93		333831 <u>323034</u> 		⊕ 1,3		343265 <u>353012</u>	553155	⊥ ⊖ 0,6
 Exc. Sport, GSi	3.93- 9.00	633831	333831 <u>323034</u> 		⊕ 1,3	443225	343265 <u>353012</u>	553155	⊥ ⊖ 0,6



MODEL FAHRZEUG MODELE	YEAR JAHR ANNEE	FRONT/VORNE/AVANT				REAR/HINTEN/ARRIERE			
		PREMIUM Oil	EXCEL-G* Twin-tube Gas	GAS-A-JUST Mono-tube Gas		PREMIUM Oil	EXCEL-G* Twin-tube Gas	GAS-A-JUST Mono-tube Gas	
<b>Opel (D)</b>									
<b>Corso A, Corso B</b>									
1.4i Sport, 1.4Si Sport, 1.5TD Sport 1.6i-16V GSi	3.93- 9.00		333831 <u>323034</u> SM1302 ▼ SM2302		 1,3		343265 <u>353012</u>	553155	 ⊥ ⊕ 0,6
<b>Corso C</b>									
1.0, 1.2 Exc.  , Sport sus.	9.00-		333946 L 333945 R				343350		 ⊥ ⊕
1.4, 1.8, 1.7Di, 1.7DTI Exc.  , Sport sus.	9.00-		333946 L 333945 R				343351		 ⊥ ⊕
<b>Frontera</b>									
(52SU, 53MW, 5JMW)  Incl. Sport	10.91- 9.95	444120	344227		 ⊥ ⊕ 0,7	444122	344228		 ⊕ ⊕ 0,4
(54/55/5B/5K SU,54/55/5B/5K MW)  Incl. Sport	9.95-10.98		344227		 ⊥ ⊕		344229		 ⊕ ⊕
 Incl. Sport	10.98-		344298		 ⊥ ⊕		344299		 ⊥ ⊕
<b>Kadett, Olympia, Aero</b>									
Kadett A Kadett B Kadett Rallye	63- 67 65- 67 67- 73	443024	343080	553127	 ⊥ ⊕				
Kadett B, Olympia A Exc. Kadett Rallye	68- 73	443024	343080	553127	 ⊥ ⊕	443025	343081	553010	 ⊥ ⊕
 Kadett C, SR Aero	73- 79 76- 79	443026	343048	553009 <u>244029</u>	 ⊥ ⊕ 0,5	443027	343006	554011 <u>244030</u>	 ⊥ ⊕ 0,6
 Kadett C, City (SR) Kadett 1.6 ltr. Caravan	73- 79 5.77- 79	443026	343048	553009	 ⊥ ⊕ 0,5	443025	343081	553010	 ⊥ ⊕ 0,6
Kadett D 1.2, 1.3, 1.3S, SR	79- 8.84	665036	365025 <u>375009</u> 		 ⊥ 2,1	443134	343047	553075 <u>243014</u>	 ⊥ ⊕ 0,6
Kadett D  	79- 8.84	665036	365025 <u>375009</u> 		 ⊥ 2,1	443135	343099	553137	 ⊕ ⊥ 0,6

\*Excel-G is a new name of SUPER  
Excel-G ist der neue Name für SUPER  
Excel-G est le nom nouveau pour SUPER

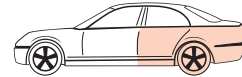
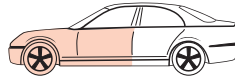

MODEL FAHRZEUG MODELE	YEAR JAHR ANNEE	FRONT/VORNE/AVANT				REAR/HINTEN/ARRIERE			
		PREMIUM Oil	EXCEL-G* Twin-tube Gas	GAS-A-JUST Mono-tube Gas		PREMIUM Oil	EXCEL-G* Twin-tube Gas	GAS-A-JUST Mono-tube Gas	
<b>Opel (D)</b>									
<b>Kadett, Olympia, Aero</b>									
Kadett E  Exc. GSI, GSE	9.84- 91	665036	365025 375009 SM1300 <sup>1)</sup> SM1307 <sup>2)</sup>		 2,1	443134	343047	553075 243014	 ⊥ ⊖ 0,6
Kadett E  1.8 GSI, GSE	9.84- 91		365025 375009 SM1307		 2,1		343047	553075 243014	 ⊥ ⊖ 0,6
Kadett E  	9.84- 91	665036	365025 SM1300 <sup>1)</sup> SM1307 <sup>2)</sup>		 2,1	443135	343099	553137	 ⊖ ⊥ 0,6
Kadett E Combo  	9.85- 93	665036	365025 SM1300 <sup>1)</sup> SM1307 <sup>2)</sup>		 2,1	443233	343227		 ⊖ ⊖ 0,6
1) SM1300 1.2/1.3/1.4/1.6 2) SM1307 1.6   /1.8/2.0/Diesel									
<b>Monterey</b>									
(UBS)	92- 3.95		344279		 ⊥ ⊖		344229		 ⊖ ⊖
(UBS)	4.95- 3.98		344279		 ⊥ ⊖		344229		 ⊖ ⊖
<b>Omega A, Omega B </b>									
Omega A 1.8, 2.0, 2.4i, 2.3 D, 2.3 TD Exc.	9.86- 4.94	634022 L 634021 R	334100 L 334099 R SM1304		 2,8	443234	343216 Exc.	553162	 ⊥ ⊖ 0,6
Omega A 2.6i, 3.0i, 3.0i-24V, 3000, 3000-24V Exc.	9.86- 4.94		334100 L 334099 R 		 2,8		343216 Exc.	553162	 ⊥ ⊖ 0,6
Omega B  Exc. , 2.5i, 3.0i	94-		334903 SM1304		 2,7		343216 Exc.	553162	 ⊥ ⊖ 0,6
Omega B 2.5i, 3.0i Exc.	94-		334903		 2,7		343216 Exc.	553162	 ⊥ ⊖ 0,6





MODEL FAHRZEUG MODELE	YEAR JAHR ANNEE	FRONT/VORNE/AVANT			⌚	REAR/HINTEN/ARRIERE			⌚
		PREMIUM Oil	EXCEL-G* Twin-tube Gas	GAS-A-JUST Mono-tube Gas		PREMIUM Oil	EXCEL-G* Twin-tube Gas	GAS-A-JUST Mono-tube Gas	
<b>Opel (D)</b>									
<b>Omega A Caravan, Omega B Caravan</b>									
Omega A Caravan 2.0, 2.3 D, 2.3 TD, 2.4 Exc.	9.86- 4.94	634022 L 634021 R	334100 L 334099 R		⊕ 2,8	444095	344256 Exc.	554088	⊥ ⊖ 0,6
		915329  SM1304							
Omega A Caravan 2.6 i, 3.0 i, 3.0i-24V Exc.	9.86- 4.94		334100 L 334099 R		⊕ 2,8		344256 Exc.	554088	⊥ ⊖ 0,6
		915329							
Omega B Caravan  Exc.  , 2.5i, 3.0i	94-		334903		⊕ 2,7		344256 Exc.	554088	⊥ ⊖ 0,6
		SM1304							
Omega B Caravan 2.5i, 3.0i Exc.	94-		334903		⊕ 2,7		344256 Exc.	554088	⊥ ⊖ 0,6
<b>Rekord</b>									
Rekord A, B, C	63- 1.72	443029	343005	553012	⊥ ⊖ 0,5	443030	343049	554012	⊥ ⊖ 0,7
Rekord D 1.7, 1.9, 2.0, Sprint Rekord D 2.1 Diesel	72- 7.77 5.72- 8.78	443029	343005	553012	⊥ ⊖ 0,5	443027	343006	554011	⊥ ⊖ 0,7
Rekord E 1.7, 1.8, 1.9, 2.0, 2.2	8.77- 9.86	665035	365007		⊥ 2,3	443027	343006	554011	⊥ ⊖ 0,7
		915322							
Rekord E 2.0 D, 2.3 D, 2.3 TD	77- 9.86	665056			⊥ 2,3	443027	343006	554011	⊥ ⊖ 0,7
		915322							
<b>Rekord Caravan</b>									
Rekord A, B	63- 68	443029	343005		⊥ ⊖ 0,5				
Rekord C	67- 1.72	443029	343005		⊥ ⊖ 0,5	443030	343049	554012	⊥ ⊖ 0,7
Rekord D 1.7,1.9, 2.0, 2.1 D	1.72- 7.77	443029	343005		⊥ ⊖ 0,5	443031	343007	554013	⊥ ⊖ 0,7
Rekord E 1.7, 1.8, 1.9, 2.0, 2.2, 2.3 D	8.77- 9.86	665035	365007		⊥ 2,3	443031	343007	554013	⊥ ⊖ 0,7
		915322							
<b>Senator, Monza (Exc.  )</b>									
Monza A Senator A	5.78- 8.87	665056			⊥ 2,3		343044 Exc.	554029	⊥ ⊖ 0,7
		915322							

\*Excel-G is a new name of SUPER  
 Excel-G ist der neue Name für SUPER  
 Excel-G est le nom nouveau pour SUPER

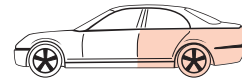
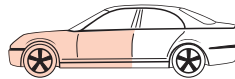

MODEL FAHRZEUG MODELE	YEAR JAHR ANNEE	FRONT/VORNE/AVANT				REAR/HINTEN/ARRIERE			
		PREMIUM Oil	EXCEL-G* Twin-tube Gas	GAS-A-JUST Mono-tube Gas		PREMIUM Oil	EXCEL-G* Twin-tube Gas	GAS-A-JUST Mono-tube Gas	
<b>Opel (D)</b>									
<b>Senator, Monza (Exc.  )</b>									
Senator B 2.3 TD, 2.6	9.87- 95	634022 L 634021 R	334100 L 334099 R			443234	343216	553162	
					2,8		Exc.		
Senator B 2.5	9.87- 95	634022 L 634021 R	334100 L 334099 R			443234	343216	553162	
					2,8		Exc.		
Senator B 3.0i, 3.0i-24V	9.87- 95		334100 L 334099 R				343216	553162	
					2,8		Exc.		
<b>Tigra</b>									
	94-		333831 323034				343265 353012	553155	
<b>Vectra A</b>									
 1.4, 1.6 i, 1.8 S, 1.8 i, 2.0 i 1.7D, 1.7TD	9.88- 95	665063	365071 375032			443134	343047	553075	
				<sup>1)</sup> <sup>2)</sup>	2,1		Exc.	<u>243014</u>	
2000-16V (  = 20XE, C 20XE) → NV199999, → N1999999 → N5999999	9.88- 92	665063	365071			443234	343216	553162	
				<sup>1)</sup> <sup>2)</sup>	2,1		Exc.		
2000-16V (  = 20XE, C 20XE) P1000001 →, P5000001 → P7000001 →	93- 95	665063	365071 375032			443134	343047	553075	
				<sup>1)</sup> <sup>2)</sup>	2,1		Exc.	<u>243014</u>	
 2.5i -V6	93- 95		365071 375032				343047	553075	
				<sup>1)</sup> <sup>2)</sup>	2,1		Exc.	<u>243014</u>	
 1.8i, 2.0i, 2.0i-16V, 2000-16V 2.0i-16V Turbo	9.88- 95	665063	365071			443234	343216	553162	
				<sup>1)</sup> <sup>2)</sup>	2,1		Exc.		
1) SM1301 : Exc. GT    2) SM1306 : GT									



MODEL FAHRZEUG MODELE	YEAR JAHR ANNEE	FRONT/VORNE/AVANT				REAR/HINTEN/ARRIERE			
		PREMIUM Oil	EXCEL-G* Twin-tube Gas	GAS-A-JUST Mono-tube Gas		PREMIUM Oil	EXCEL-G* Twin-tube Gas	GAS-A-JUST Mono-tube Gas	
<b>Opel (D)</b>									
<b>Vectra B</b>									
1.6 i, 1.8 i, 1.7 TD, 2.0 i, 2.0 Di Incl. 16V Exc. Sport sus.	9.95-		333913 L▼ 333912 R▼  333716 L 333715 R		⊕  1,5		341907  Exc.		⊥ ⊕ 1,8
2.5 i -V6 Exc. Sport sus.	9.95-		334601 L 334600 R		⊕  1,5		341907  Exc.		⊥ ⊕ 1,8
⊕ Sport sus. 	9.95-		334610 L 334609 R		⊕  1,5		341907  Exc.		⊥ ⊕ 1,8
<b>Zafira</b>									
1.6-16V, 1.8-16V, 2.0Di	99-		334603 L 334602 R		⊕		343308	553242	⊕ ⊕
<b>Opel Commercial (D)</b>									
<b>Blitz (Bedford CF)</b>									
 	74-	444045 445010 <sup>1)</sup>			⊥	444046 445011 <sup>1)</sup>			○ ○
1) 445010, 445011: Heavy Duty									
<b>Campo/Brava</b>									
  (TFR Series)	92-	443190		553119	⊥ ⊕	443295		553230	○ ○
  (TFS Series)	92-	443216		553171	⊥ ⊕	443295		553230	○ ○
<b>Corsa Combo</b>									
	10.93-	633831	333831 SM1302▼ SM2302		⊕  1,3	443233	343227		⊕ ⊕
<b>Movano</b>									
2.5 D 2.8 TD	7.98-		344306		⊕ ⊕				
1.9 DTi 2.2 DTi	9.00-		344306		⊕ ⊕				

\* Excel-G is a new name of SUPER  
Excel-G ist der neue Name für SUPER  
Excel-G est le nom nouveau pour SUPER

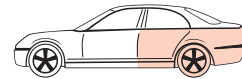
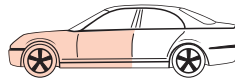

MODEL FAHRZEUG MODELE	YEAR JAHR ANNEE	FRONT/VORNE/AVANT				REAR/HINTEN/ARRIERE			
		PREMIUM Oil	EXCEL-G* Twin-tube Gas	GAS-A-JUST Mono-tube Gas		PREMIUM Oil	EXCEL-G* Twin-tube Gas	GAS-A-JUST Mono-tube Gas	
<b>Opel Commercial (D)</b>									
<b>Movano </b>									
 E9*	7.98-						344307		
 J9*  ,	7.98-						344307		
 J9*  ,	7.98-						344307		
 F90* , F92B, F92E, F93*	7.98-						344307		
 H9, U9	7.98-								
<b>Peugeot (F)</b>									
<b>104 </b>									
L, GL  → 5534418 GL6  → 7070747	73- 8.76 74- 8.76	664004	364008						
GL  5534419 → 5675804 GL 6  7070748 → 7182579 SL  → 7182579	9.76- 2.79	664004	364008			441027	341024		
GL  5675805 → SL, GL 6  7182580 → S  → 5852871 SR, GR  =	3.79- 88 3.79- 88 9.78- 80 3.79- 88	664017 <sup>1)</sup> 633021				441027	341024		
S  5852872 → GL 6 Export  5675806 → 5852671	80-	633021	333020			441027	341024		
1)									
<b>104 </b>									
ZL, ZS → 5534418	9.73- 77	664004	364008						
ZL  5534419 → 5684481 ZS  5534419 → 5684067 ZA  5534419 → 5684441	77- 3.78	664004	364008			441041	341039		



MODEL FAHRZEUG MODELE	YEAR JAHR ANNEE	FRONT/VORNE/AVANT				REAR/HINTEN/ARRIERE			
		PREMIUM Oil	EXCEL-G* Twin-tube Gas	GAS-A-JUST Mono-tube Gas		PREMIUM Oil	EXCEL-G* Twin-tube Gas	GAS-A-JUST Mono-tube Gas	
<b>Peugeot (F)</b>									
<b>104</b>									
ZL  5684482 → ZS  5684068 → ZA  5684442 → ZR, Z, ZS 2  =	4.78- 88 4.78- 88 4.78- 88 4.78- 88	664017 <sup>1)</sup>   633021	   333020	   4,0	 5,0  4,0	441041	341039	   	 ⊥ 2,5
<b>106</b>									
 Exc. 1.6-16V	91- 96 96-	665067	365087 <u>375036</u> SM1902 <sup>2)</sup> SM1903 <sup>3)</sup>	 1,1	 1,1	441065	341101	551052 <u>241006</u>	 ⊥ 0,6
1.6-16V 1.6-16V	94- 96 96-		365087 <u>375036</u> SM1902 <sup>2)</sup> SM1903 <sup>3)</sup>	 1,1	 1,1		341101	551052 <u>241006</u>	 ⊥ 0,6
<b>204, 304</b>									
204 	2.70- 76	664006	364010			441028 <sup>4)</sup>	341025 <sup>4)</sup>		 ⊥
304 	2.70- 9.72	664006	364010			441028 <sup>4)</sup>	341025 <sup>4)</sup>		 ⊥
304 	10.72- 77	664006	364010			441029 <sup>5)</sup>	341026 <sup>5)</sup>		 ⊥
304 4031501 →	9.77- 82	664010	364011			441029 <sup>5)</sup>	341026 <sup>5)</sup>		 ⊥
<b>204, 304 Break, Fourgonette</b>									
204 	2.70- 9.72	664006	364010			441028 <sup>4)</sup>	341025 <sup>4)</sup>		 ⊥
204 	10.72- 76	664006	364010			441029 <sup>5)</sup>	341026 <sup>5)</sup>		 ⊥
304 	70- 9.74	664006	364010			441029 <sup>5)</sup>	341026 <sup>5)</sup>		 ⊥
1)       2)  → 50265608      3)  50265609 →      4) 441028 341025  ← !      5) 441029 341026  ← !									

Peugeot

\* Excel-G is a new name of SUPER  
Excel-G ist der neue Name für SUPER  
Excel-G est le nom nouveau pour SUPER



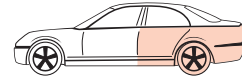
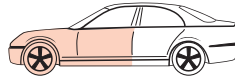

MODEL FAHRZEUG MODELE	YEAR JAHR ANNEE	FRONT/VORNE/AVANT				REAR/HINTEN/ARRIERE			
		PREMIUM Oil	EXCEL-G* Twin-tube Gas	GAS-A-JUST Mono-tube Gas		PREMIUM Oil	EXCEL-G* Twin-tube Gas	GAS-A-JUST Mono-tube Gas	
<b>Peugeot (F)</b>									
<b>204, 304 Break, Fourgonette </b>									
304 4031501 →	10.74- 82	664010	364011		□	441029 <sup>1)</sup>	341026 <sup>1)</sup>		
<b>205</b>									
,  XA, XAD Exc.GTi, CTi, Rally, Turbo-Diesel	83-	633828	333828 <u>324013 L</u> <u>324012 R</u>		 3,5	443220	343229 <u>354001</u>	553138	 1,1
 Rally, Turbo Diesel	83-				 3,5	444091	344112	554065	 1,1
 1.6 GTi, 1.9 GTi	2.84-	634011 L 634010 R	334023 L 334022 R <u>324013 L</u> <u>324012 R</u>		 3,5	444091	344112 <u>354001</u>	554065	 1,1
 CT, CJ	86- 94	633828	333828 <u>324013 L</u> <u>324012 R</u>		 3,5	443220	343229 <u>354001</u>	553138	 1,1
 CTi	86- 94	633830	333830		 3,5	443220	343229	553138	 1,1
1) 441029 341026   ! 2) for 324012 R/324013 L      3) for 634010 R/634011 L, 334022 R/334023 L, 324012 R/324013 L									
<b>206 </b>									
1.1i Exc. , XA, Entrepise	9.98-	633931 ▼ 633930 L 633929 R	333931 ▼ 333930 L 333929 R <u>323055 L</u> <u>323054 R</u>		 2,8	441110	341249 <u>351025</u>		 0,6
1.4i, 1.6i, 1.9D, 2.0HDI Exc. , Entrepise	9.98-	633930 L 633929 R	333930 L 333929 R <u>323055 L</u> <u>323054 R</u>		 2,8	441110	341249 <u>351025</u>		 0,6

\*Excel-G is a new name of SUPER  
Excel-G ist der neue Name für SUPER  
Excel-G est le nom nouveau pour SUPER



MODEL FAHRZEUG MODELE	YEAR JAHR ANNEE	FRONT/VORNE/AVANT			⌚	REAR/HINTEN/ARRIERE			⌚
		PREMIUM Oil	EXCEL-G* Twin-tube Gas	GAS-A-JUST Mono-tube Gas		PREMIUM Oil	EXCEL-G* Twin-tube Gas	GAS-A-JUST Mono-tube Gas	
<b>Peugeot (F)</b>									
<b>206</b>									
Entreprise 1.1i XA, 1.4i XA, 1.9D Exc.	9.98-	633930 L 633929 R	333930 L 333929 R		⊕ 2,8	441111	341250		⊖ 0,6
<b>206 CC</b>									
	01-		333930 L 333929 R		⊕		341250		⊖
<b>305</b>									
GL, GLS, GR, S, SR, GLD, GRD, SRD → 8870212	77- 82	664010	364011		⊖ 6,0	441042			⊖ ⊗
GL, GLS, GR, S, SR, GLD, GRD, SRD 8870213 → 8987000	82- 6.82	664010	364011		⊖ 6,0	441960	341960		⊖ ⊗ 2,5
S, GL, GLS  8987001 → GR, SR  8987001 → 9524000	7.82- 86	633829	333829	SM1900 <sup>1)</sup>	⊕ 4,0	441960	341960		⊖ ⊗ 2,5
S, GL, Automatic  9370001 → GR, SR  9524001 →	86- 88	633829	333829	SM1900 <sup>1)</sup>	⊕ 4,0	441961	341961		⊖ ⊗ 2,5
GLD, GRD, SRD 8987001 →	7.82- 88	633829	333829	SM1900 <sup>1)</sup>	⊕ 4,0	441960	341960		⊖ ⊗ 2,5
GT, GTX	83- 88	633829	333829	SM1900 <sup>1)</sup>	⊕ 4,0	441961	341961		⊖ ⊗ 2,5
<b>305</b>									
 → 8987000	78- 6.82	664010	364011		⊖ 6,0	441962	341962		⊖ ⊗ 2,0
 8987001 →	7.82- 89	633829	333829	SM1900 <sup>1)</sup>	⊕ 4,0	441962	341962		⊖ ⊗ 2,0
1)  9404640 →									

\* Excel-G is a new name of SUPER  
 Excel-G ist der neue Name für SUPER  
 Excel-G est le nom nouveau pour SUPER

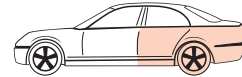
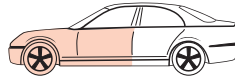

MODEL FAHRZEUG MODELE	YEAR JAHR ANNEE	FRONT/VORNE/AVANT				REAR/HINTEN/ARRIERE			
		PREMIUM Oil	EXCEL-G* Twin-tube Gas	GAS-A-JUST Mono-tube Gas		PREMIUM Oil	EXCEL-G* Twin-tube Gas	GAS-A-JUST Mono-tube Gas	
<b>Peugeot (F)</b>									
<b>306</b>									
 1.1 1.4 Exc. 175-70-, 175-65-	93- 2.97	633839 L 633838 R	333839 L 333838 R <u>323839 L</u> <u>323838 R</u> SM1907 <sup>1)</sup> SM1908 <sup>2)</sup>		 1,5	441092  H/D 441093	341166	551060  <u>241008</u>	  0,9
 1.4  175-70-, 175-65- 1.6, 1.8, 1.9D, 1.9TD  Exc. 2.0, 2.0-16V	93- 2.97  94- 2.97	633839 L 633838 R	333839 L 333838 R <u>323839 L</u> <u>323838 R</u> SM1907 <sup>1)</sup> SM1908 <sup>2)</sup>		 1,5	441093	341166	551060  <u>241008</u>	  0,9
 1.4 Exc. 175-70-	3.97- 01	633839 L 633838 R	333839 L 333838 R <u>323839 L</u> <u>323838 R</u> SM1907 <sup>1)</sup> SM1908 <sup>2)</sup>		 1,5	441092  H/D 441093	341166	551060  <u>241008</u>	  0,9
 1.4  175-70- 1.6, 1.8, 1.9D, 1.9TD  Exc. 2.0, 2.0-16V	3.97- 01  3.97- 01	633839 L 633838 R	333839 L 333838 R <u>323839 L</u> <u>323838 R</u> SM1907 <sup>1)</sup> SM1908 <sup>2)</sup>		 1,5	441093	341166	551060  <u>241008</u>	  0,9
 2.0, 2.0-16V	93- 2.97 3.97- 01		333839 L 333838 R <u>323839 L</u> <u>323838 R</u> SM1907 <sup>1)</sup> SM1908 <sup>2)</sup>		 1,5	441093	341166	551060  <u>241008</u>	  0,9
 	93- 2.97 3.97-		333839 L 333838 R <u>323839 L</u> <u>323838 R</u> SM1907 <sup>1)</sup> SM1908 <sup>2)</sup>		 1,5	441093	341166	551060  <u>241008</u>	  0,9

1)

2)





MODEL FAHRZEUG MODELE	YEAR JAHR ANNEE	FRONT/VORNE/AVANT				REAR/HINTEN/ARRIERE			
		PREMIUM Oil	EXCEL-G* Twin-tube Gas	GAS-A-JUST Mono-tube Gas		PREMIUM Oil	EXCEL-G* Twin-tube Gas	GAS-A-JUST Mono-tube Gas	
<b>Peugeot (F)</b>									
<b>306</b>									
 ALL	3.97-		333839 L 333838 R <u>323839 L</u> <u>323838 R</u> SM1907 <sup>1)</sup> SM1908 <sup>2)</sup>		 1,5	441093	341166	551060 <u>241008</u>	 0,9
 ALL	94- 2.97 3.97-		333839 L 333838 R <u>323839 L</u> <u>323838 R</u> SM1907 <sup>1)</sup> SM1908 <sup>2)</sup>		 1,5	441093	341166	551060 <u>241008</u>	 0,9
<b>309</b>									
 ALL Exc. GT, GT injection, Turbo Diesel, 1.9SR	85- 93	633830	333830 SM1900		 3,0	443220	343229	553138	 0,6
GT, GT injection, Turbo Diesel, 1.9 SR	85- 93	634011 L 634010 R	334023 L 334022 R <u>324013 L</u> <u>324012 R</u> SM1900		 3,0	443220	343229 <u>354001</u>	553138	 0,6
<b>404</b>									
 5065744 →	66- 75	663046				444077			
 ALL	67- 76	663046							
 U 8, U 10	66- 76	663046				445021			
<b>405</b>									
 2WD Exc. MI 16, GRI, SRI,	87- 96	633829	333829 <u>324014</u> 913112 <sup>3)</sup> SM1914 <sup>4)</sup> SM1901 <sup>5)</sup> SM1904 <sup>6)</sup>		 3,0	441066	341102 <u>351014</u>	551053	 0,6
1)   2)   3) for 324014 4)  → S8026754 5)  S8026755 → 6.92 6)  7.92 →									

\*Excel-G is a new name of SUPER  
Excel-G ist der neue Name für SUPER  
Excel-G est le nom nouveau pour SUPER

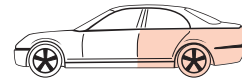
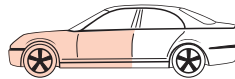

MODEL FAHRZEUG MODELE	YEAR JAHR ANNEE	FRONT/VORNE/AVANT				REAR/HINTEN/ARRIERE			
		PREMIUM Oil	EXCEL-G* Twin-tube Gas	GAS-A-JUST Mono-tube Gas		PREMIUM Oil	EXCEL-G* Twin-tube Gas	GAS-A-JUST Mono-tube Gas	
<b>Peugeot (F)</b>									
<b>405</b>									
2WD MI 16, GRI, SRI Exc.	87- 96		333829 <u>324014</u> 1)  SM1914 <sup>2)</sup> SM1901 <sup>3)</sup> SM1904 <sup>4)</sup>		 3,0	441066	341102 <u>351014</u>	551053	 0,6
4WD Exc.	87- 96	633829	333829 <u>324014</u> 1)  SM1914 <sup>2)</sup> SM1901 <sup>3)</sup> SM1904 <sup>4)</sup>		 3,0		OE =		
1) for 324014 2)  → S8026754 3)  S8026755 → 6.92 4)  7.92 →									
<b>406 Exc. </b>									
1.6 1.8 1.8-16V 1.9 D 1.9 TD  → 7664 2.0  → 7664 2.0-16V  → 7664 Exc.	11.95- 5.97- 11.95- 11.95- 1.96- 11.95- 10.96-	633928 L 633927 R	333928 L 333927 R SM1915		 1,7	441102	341229		 1,0
1.9 TD  7665 → 2.0  7665 → 2.0-16V  7665 → 2.0 Turbo 2.1 TD 3.0 V6 Exc.	- - - 4.96- 1.96- 10.96-	633926 L 633925 R	333926 L 333925 R SM1915		 1,7	441102	341229		 1,0
2.0 HDI, 2.2 HDI Exc.	2.99-	633926 L 633925 R	333926 L 333925 R SM1915		 1,7	441102	341229		 1,0
	11.95-		SM1915		 1,7	441104	341231		 1,0
1.8-16V, 2.0-16V, 3.0-V6 Exc.	3.97-	633926 L 633925 R	333926 L 333925 R SM1915		 1,7	441103	341230		 1,0

\*Excel-G is a new name of SUPER  
Excel-G ist der neue Name für SUPER  
Excel-G est le nom nouveau pour SUPER



MODEL FAHRZEUG MODELE	YEAR JAHR ANNEE	FRONT/VORNE/AVANT				REAR/HINTEN/ARRIERE			
		PREMIUM Oil	EXCEL-G* Twin-tube Gas	GAS-A-JUST Mono-tube Gas		PREMIUM Oil	EXCEL-G* Twin-tube Gas	GAS-A-JUST Mono-tube Gas	
<b>Peugeot (F)</b>									
<b>406 Exc. </b>									
 1.8 1.8-16V 1.9 D  → 7664 1.9 TD  → 7664 2.0-16V  → 7664 Exc.	5.97- 10.96- 10.96- 10.96- 10.96-	633928 L 633927 R	333928 L 333927 R		 1.7	441104	341231		 1.0
 1.9 D  7665 → 1.9 TD  7665 → 2.0-16V  7665 → 2.0 Turbo 2.1 TD 3.0-V6 Exc.	- - - 10.96- 10.96- 10.96-	633926 L 633925 R	333926 L 333925 R		 1.7	441104	341231		 1.0
 2.0 HDI, 2.2 HDI Exc.	2.99-	633926 L 633925 R	333926 L 333925 R		 1.7	441104	341231		 1.0
 	10.96-				 1.7	441104	341231		 1.0
<b>504 </b>									
GL, GLD, Ti → 2181356	68- 76	664007			 5.8	444036	344004	554032	 0.8
L, LD → 2181356	73- 76	664007			 5.8	444037		554033	 0.8
GLD, Ti  2181357 → GL  2181357 → 3972015	76- 80 76- 85	664008	364002		 5.8	444036	344004	554032	 0.8
L, LD  2181357 → GR, SR, GRD  → 3972015 SRD  =	76- 80 80- 85 80- 83	664008	364002		 5.8	444037		554033	 0.8
GL 3972016 →	85-	664018 <sup>1)</sup> 664008 <sup>2)</sup>	364002 <sup>2)</sup>		 5.8	444036	344004	554032	 0.8
GR, SR, GRD 3972016 →	85-	664018 <sup>1)</sup> 664008 <sup>2)</sup>	364002 <sup>2)</sup>		 5.8	444037		554033	 0.8
1) Exc.   = SHORT  Lmax = 190 mm      2)   = SHORT  Lmax = 180 mm									
<b>504 </b>									
 → 2085065	68- 76	664007			 5.8	444036	344004	554032	 0.8

Peugeot

\* Excel-G is a new name of SUPER  
Excel-G ist der neue Name für SUPER  
Excel-G est le nom nouveau pour SUPER



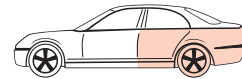
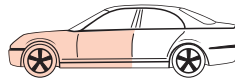

MODEL FAHRZEUG MODELE	YEAR JAHR ANNEE	FRONT/VORNE/AVANT			 ⌚	REAR/HINTEN/ARRIERE			 ⌚
		PREMIUM Oil	EXCEL-G* Twin-tube Gas	GAS-A-JUST Mono-tube Gas		PREMIUM Oil	EXCEL-G* Twin-tube Gas	GAS-A-JUST Mono-tube Gas	
<b>Peugeot (F)</b>									
<b>504</b>									
2085066 →	76- 83	664008	364002		⌚ 5,8	444036	344004	554032	⊥ 0,8
<b>504</b>									
L, LD, GL, GLD → 2181356	72- 76	664007			⌚ 5,8	441963			⊥ 0,8
GL, GLD  2181357 → L, LD  2181357 → 3972015 GR, GRD  2181357 → 3972015	76- 80 76- 85 76- 85	664008	364002		⌚ 5,8	441963			⊥ 0,8
L, LD, GR, GRD 3972016 →	85-	664018 <sup>1)</sup> 664008 <sup>2)</sup>	364002 <sup>2)</sup>		⌚ 5,8	441963			⊥ 0,8
<b>505</b>									
GL, GR, SR, STi, Turbo-injection GLD, GRD, SRD, SRD Turbo → 1469621	79- 83	664018			⌚ 6,0	444036	344004	554032	⊥ 0,8
GL, SL, GR, SR, Ti, STi, GTi, GLD, GRD, SRD, SRD Turbo, GTD Turbo, GRD Turbo 1469622 → 1845000 Turbo-injection 1469622 → 1887751	83- 85 83- 86	664018 <sup>1)</sup> 664008 <sup>2)</sup>	364002 <sup>2)</sup>		⌚ 6,0	444036	344004	554032	⊥ 0,8
GL, SL, GR, SR, GTi, GLD, GRD, SRD, SRD Turbo, GTD Turbo, GRD Turbo 1845001 → Turbo-injection Exc. ⊕ ABS 1887752 →	86- 86-	665065		SM1909	⌚ 6,0	444036	344004	554032	⊥ 0,8
Turbo-injection ⊕ ABS 1965001 →	87-				⌚ 6,0	444036	344004	554032	⊥ 0,8
<b>505</b>									
GL, GLD	82- 83	664008	364002		⌚ 6,0	444088			⊥ 0,8
GR, SR, GRD, SRD GL, GTi, GLD, GTD Turbo → 1845000	82- 86 84- 86	664018 <sup>1)</sup> 664008 <sup>2)</sup>	364002 <sup>2)</sup>		⌚ 6,0	444088			⊥ 0,8
GL, GR, GTi, GLD, GRD, GTD, GTD Turbo, GRD Turbo 1845001 →	86-	665065		SM1909	⌚ 6,0	444088			⊥ 0,8
<p>1) Exc.  = SHORT  Lmax =190 mm</p> <p>2) ⊕  = SHORT  Lmax =180 mm</p>									

Peugeot



MODEL FAHRZEUG MODELE	YEAR JAHR ANNEE	FRONT/VORNE/AVANT				REAR/HINTEN/ARRIERE			
		PREMIUM Oil	EXCEL-G* Twin-tube Gas	GAS-A-JUST Mono-tube Gas		PREMIUM Oil	EXCEL-G* Twin-tube Gas	GAS-A-JUST Mono-tube Gas	
<b>Peugeot (F)</b>									
<b>604</b>									
SL, Ti, STi, Turbo Diesel → 6648440	74- 3.82	664018				444036	344004	554032	
					6,0				$\perp$ 1,8
Ti, STi, GRD, SRD, Turbo-Diesel 6648441 →	4.82- 86	664008	364002			444036	344004	554032	$\perp$ 1,8
					6,0				
<b>605</b>									
 Exc.	89- 95	633903 L 633902 R	333903 L 333902 R			441088	341195		$\perp$ 3,0
					1,4				
 Exc.	95- 99	633961 L 633960 R	333961 L 333960 R			441088	341195		$\perp$ 3,0
<b>806</b>									
	94- 1.98	634927	334927			443277 <sup>1)</sup>	343296 <sup>1)</sup>		$\perp$ 1,6
			SM1916 L SM1917 R		2,3				
	1.98- 8.00	634927	334927			443303 <sup>2)</sup>	343321 <sup>2)</sup>		$\perp$ 1,6
			SM1916 L SM1917 R		2,3				
	9.00-	634927	334927			443303 <sup>2)</sup>	343321 <sup>2)</sup>		$\perp$ 1,6
			SM1916 L SM1917 R		2,3				
1)  L max. = 370mm                2)  L max. = 400 mm									
<b>Peugeot Commercial (F)</b>									
<b>504</b>									
→ 3610000	79- 82	665062				445021			$\perp$ 0,8
3610001 →	82-					445021			$\perp$ 0,8
<b>Boxer</b>									
 Incl. Exc. H/D, Camping Car	94-	635852					344283		$\perp$ 0,8
			SM1920 L SM1921 R						

Peugeot

\* Excel-G is a new name of SUPER  
 Excel-G ist der neue Name für SUPER  
 Excel-G est le nom nouveau pour SUPER



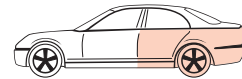
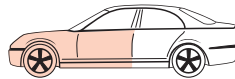

MODEL FAHRZEUG MODELE	YEAR JAHR ANNEE	FRONT/VORNE/AVANT			 Ⓛ	REAR/HINTEN/ARRIERE			 Ⓛ
		PREMIUM Oil	EXCEL-G* Twin-tube Gas	GAS-A-JUST Mono-tube Gas		PREMIUM Oil	EXCEL-G* Twin-tube Gas	GAS-A-JUST Mono-tube Gas	
<b>Peugeot Commercial (F)</b>									
<b>Boxer</b>									
  Exc. H/D, Camping Car	94-	635853			⊕		345021		⊖
				SM1920 L SM1921 R					
<b>Expert</b>									
	96- 8.97	634928	334928		⊕	441106 <sup>1)</sup>	341238 <sup>1)</sup>		⊖
				SM1916 L SM1917 R					
	9.97- 8.00	634928	334928		⊕	441107 <sup>2)</sup>	341239 <sup>2)</sup>		⊖
				SM1916 L SM1917 R					
	9.00-	634928	334928		⊕	441107 <sup>2)</sup>	341239 <sup>2)</sup>		⊖
				SM1918 L SM1919 R					
1)  L max. = 370mm                2)  L max. = 400 mm									
<b>J5</b>									
Incl. → 0244300 Exc.	81- 85	635850			⊕	445022			⊖
				SM1801	2,7				0,7
Exc. 0244301 → Exc.	85- 94	635851			⊕	445022			⊖
				SM1801	2,7				0,7
 0244301 → 0327500 Exc.	85- 87	635851			⊕	445022			⊖
				SM1801	2,7				0,7
 0327501 → Exc.	87- 94	635851			⊕				
				SM1801	2,7				
<b>J7</b>									
Fourgon	66- 80	441060			⊖	443237			⊖
					3,0				1,4
<b>J9</b>									
Fourgon → 4161496	79- 86	441060			⊖	443237			⊖
					3,0				1,4
Fourgon 4161497 →	86- 94					443237			⊖
									1,4



MODEL FAHRZEUG MODELE	YEAR JAHR ANNEE	FRONT/VORNE/AVANT				REAR/HINTEN/ARRIERE			
		PREMIUM Oil	EXCEL-G* Twin-tube Gas	GAS-A-JUST Mono-tube Gas		PREMIUM Oil	EXCEL-G* Twin-tube Gas	GAS-A-JUST Mono-tube Gas	
<b>Peugeot Commercial (F)</b>									
<b>Partner</b>									
  	96-	633839 L 633838 R	333839 L 333838 R		+	441105	341237		
			SM1905 <sup>1)</sup> SM1906 <sup>2)</sup>						
 	96-		333839 L 333838 R		+	441105	341237		
			SM1905 <sup>1)</sup> SM1906 <sup>2)</sup>						
1)      2)									
<b>Plymouth (US) ⇒ Chrysler (US)</b>									
<b>Pontiac (US) ⇒ General Motors (US)</b>									
<b>Porsche (D)</b>									
911, 911 S, Carrera RS (Series E)	9.71- 74		361004		□ 2,5			554015	 0,5
914	7.69- 76		361004		□			551004	
924 Exc.  sports drive	76- 7.84	663005	363014		□ 1,4			553013	 0,6
928	4.77-								
944	81- 7.84	663005	363014		□ 1,4			553013	 0,6
<b>Proton (MA)</b>									
<b>Coupé</b>									
1.8	97-		334098 L <sup>1)</sup> 334097 R <sup>2)</sup>		+		341140		
1) O.E.= PW530083, PW530143, PW530241, PW530243					2) O.E.= PW530084, PW530144, PW530242, PW530244				

\* Excel-G is a new name of SUPER  
 Excel-G ist der neue Name für SUPER  
 Excel-G est le nom nouveau pour SUPER

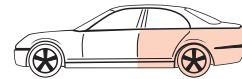
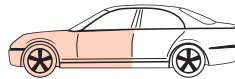

MODEL FAHRZEUG MODELE	YEAR JAHR ANNEE	FRONT/VORNE/AVANT				REAR/HINTEN/ARRIERE			
		PREMIUM Oil	EXCEL-G* Twin-tube Gas	GAS-A-JUST Mono-tube Gas		PREMIUM Oil	EXCEL-G* Twin-tube Gas	GAS-A-JUST Mono-tube Gas	
<b>Proton (MA)</b>									
<b>Persona Compact, 300 Series</b>									
1.3, 1.5 (C96, C97)	97-		333225 L 333224 R		+		341140		⊥ ⊖
1.6 (C98)	97-		334098 L 334097 R		+		341140		⊥ ⊖
<b>Persona, 400 Series</b>									
1.3, 1.5 (C96, C97)	93-11.95		333125 L <sup>1)</sup> 333124 R <sup>2)</sup>		+	441085	341140		⊥ ⊖
1.6 (C98)	93-11.95		334073 L <sup>3)</sup> 334072 R <sup>4)</sup>		+	441085	341140		⊥ ⊖
1.3, 1.5 (C96, C97)	12.95-		333225 L <sup>5)</sup> 333224 R <sup>6)</sup>		+		341140		⊥ ⊖
1.6, 1.8, 2.0D (C98, C99, C95)	12.95-		334098 L <sup>7)</sup> 334097 R <sup>8)</sup>		+		341140		⊥ ⊖
1) O.E.= MB891073		5) O.E.= PW530075, PW530077, PW530079, PW530081							
2) O.E.= MB891074		6) O.E.= PW530076, PW530078, PW530080, PW530082							
3) O.E.= MB891745		7) O.E.= PW530083, PW530143, PW530241, PW530243							
4) O.E.= MB891746		8) O.E.= PW530084, PW530144, PW530242, PW530244							
<b>Saga, Proton, Proton MPi</b>									
1.3, 1.5	85- 96	633040	333024		+	443250	343232	553165	⊖ ⊖
<b>Renault (F)</b>									
<b>Clio I (375*, 557*, 657*, B57*, C57*, S57*)</b>									
1.1	90- 7.97	633824 <sup>1)</sup>	333824 <sup>1)</sup>		+		341148	551054 551803▼	⊖ ⊖ 0,7
		SM1504			2,2				
1.2 1.4	90- 7.97	633824 <sup>1)</sup>	333824 <sup>1)</sup>		+		341148	551054 551803▼	⊖ ⊖ 0,7
		SM1504 <sup>2)</sup>			2,2				
		SM1503 <sup>3)</sup>							
		633825 <sup>1)</sup>	333825 <sup>1)</sup> 323825 <sup>1)</sup>					241009	
		SM1504 <sup>2)</sup>							
		SM1503 <sup>3)</sup>							
1.7, 1.8, 1.9 D Exc. 1.8 RSi, 1.8-16 V	90- 7.97	633825 <sup>1)</sup>	333825 <sup>1)</sup> 323825 <sup>1)</sup>		+		341148	551054▼ 551803	⊖ ⊖ 0,7
		SM1503			2,2				

\*Excel-G is a new name of SUPER  
Excel-G ist der neue Name für SUPER  
Excel-G est le nom nouveau pour SUPER





MODEL FAHRZEUG MODELE	YEAR JAHR ANNEE	FRONT/VORNE/AVANT				REAR/HINTEN/ARRIERE			
		PREMIUM Oil	EXCEL-G* Twin-tube Gas	GAS-A-JUST Mono-tube Gas		PREMIUM Oil	EXCEL-G* Twin-tube Gas	GAS-A-JUST Mono-tube Gas	

## Renault (F)

### Clio I (375\*, 557\*, 657\*, B57\*, C57\*, S57\*)

1.8 RSi (357E, 357V, C579, C57H) Exc. 1.8-16V	90- 7.97		333825 <sup>1)</sup> 323825 <sup>1)</sup> SM1503	 2,2		551054▼ 551803 241009	 0,7
1.2 1.4	7.97- 98	633824 <sup>1)</sup> 633706 <sup>1)</sup>	333824 <sup>1)</sup> SM1504 <sup>2)</sup> SM1503 <sup>3)</sup> 333706 <sup>1)</sup> SM1504 <sup>2)</sup> SM1503 <sup>3)</sup>	 2,2	341148	551054▼ 551803 241009	 0,7
1.8, 1.9 D Exc. 1.8 RSi, 1.8-16 V	7.97- 98	633706 <sup>1)</sup>	333706 <sup>1)</sup> SM1503	 2,2	341148	551054▼ 551803 241009	 0,7
1.8 RSi (357V, C57H) Exc. 1.8-16 V	7.97- 98		333706 <sup>1)</sup> SM1503	 2,2		551054▼ 551803 241009	 0,7
1.8-16 V (C575, C57D)	90- 98		333849 <sup>1)</sup> 323849 SM1503	 2,2		551068 241010	 0,7

1)

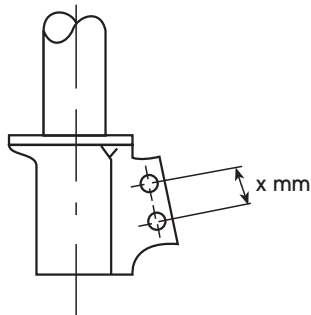

2) SM1504, 1.2L  
3) SM1503, 1.4L

X =	KYB O.E =	333824	633825	333825	633706	333706	333849
		633824		323825			323849
52 mm	7700 808 490	○					
	7700 816 045	○					
	7700 823 130	○					
	7700 828 680	○					
	7700 838 084	○					
54 mm	7700 808 491		○	○			
	7700 808 492		○	○			
	7700 816 046		○	○			
	7700 823 129		○	○			
	7700 823 131		○	○			
	7700 828 681		○	○			
	7700 828 682		○	○			
	7700 838 083		○	○			
	7700 838 086		○	○			
	7700 838 087		○	○			
	7700 828 683			○			
	7700 838 088			○			
58 mm	7700 828 684						○
	7700 838 085						○
	7700 423 726				○	○	
	7700 423 727				○	○	
	7700 423 729					○	

\*Excel-G is a new name of SUPER  
Excel-G ist der neue Name für SUPER  
Excel-G est le nom nouveau pour SUPER

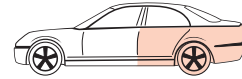
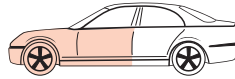

MODEL FAHRZEUG MODELE	YEAR JAHR ANNEE	FRONT/VORNE/AVANT				REAR/HINTEN/ARRIERE			
		PREMIUM Oil	EXCEL-G* Twin-tube Gas	GAS-A-JUST Mono-tube Gas		PREMIUM Oil	EXCEL-G* Twin-tube Gas	GAS-A-JUST Mono-tube Gas	

## Renault (F)

### Clio I (375\*, 557\*, 657\*, B57\*, C57\*, S57\*)

2.0-16 V Williams (C57M)	90- 98							551068 <u>241010</u>	
			SM1503						0,7
=Electric (357W, 557W)	90- 7.97	633825 <sup>1)</sup>	333825 <sup>1)</sup>						
					2,2				
=Electric (357W, 557W)	7.97- 98	633706 <sup>1)</sup>	333706 <sup>1)</sup>						
					2,2				

1)

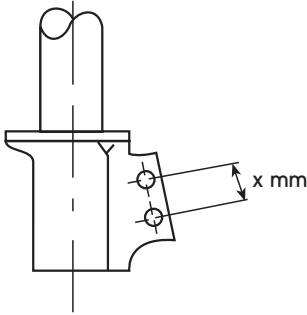

- 2) SM1504, 1.2L  
3) SM1503, 1.4L

X =	KYB O.E. =	333824	633825	333825	633706	333706	333849
		633824		323825			323849
52 mm	7700 808 490	○					
	7700 816 045	○					
	7700 823 130	○					
	7700 828 680	○					
	7700 838 084	○					
54 mm	7700 808 491		○	○			
	7700 808 492		○	○			
	7700 816 046		○	○			
	7700 823 129		○	○			
	7700 823 131		○	○			
	7700 828 681		○	○			
	7700 828 682		○	○			
	7700 838 083		○	○			
	7700 838 086		○	○			
	7700 838 087		○	○			
	7700 828 683			○			
	7700 838 088			○			
	7700 828 684						○
7700 838 085						○	
58 mm	7700 423 726				○	○	
	7700 423 727				○	○	
	7700 423 729					○	

### Clio II (BBO\*, CBO\*, SBO\*)

1.2	98-	633707	333707				343289		
			SM1507						
1.4, 1.6, 1.9D, 1.9 dTi Exc. Sport sus., 1.6-16V	98-	633708	333708				343289		
			SM1507						
1.4, 1.6, 1.9D, 1.9 dTi Sport sus.	98-		333708					553225	
			OE=7700 428 115				OE=7700 435 651		
			SM1507						
1.6-16V (CB0T)	98-		333708					553225	
			SM1507						



MODEL FAHRZEUG MODELE	YEAR JAHR ANNEE	FRONT/VORNE/AVANT				REAR/HINTEN/ARRIERE				
		PREMIUM Oil	EXCEL-G* Twin-tube Gas	GAS-A-JUST Mono-tube Gas		PREMIUM Oil	EXCEL-G* Twin-tube Gas	GAS-A-JUST Mono-tube Gas		
<b>Renault (F)</b>										
<b>Espace (2WD) , (4WD)</b>										
J112  T005813 → T036434 J115  → T028296 J117  → T003258 S112  → T000620 S115  → T000841	11.84-12.87	441080				443270	343266			
J112  T036435 → /K000001 → J115  T028297 → J116  T000001 → /K000001 → J117  T003259 → S112  T000621 → S115  T000842 →	1.88- 3.91	441069	341110			443270	343266			
2.0, 2.2, 2.1TD, 2.9-V6, 3.0-V6 (J63) Exc.	4.91- 1.97	441069	341110			443270	343266			
=2.70m 2.0, 1.9D (JEOA, JEON, JEOM)	96- 02		334960					553218		
=2.87m 2.0 (JEOA, JEON)	96- 02		334960					553219		
=2.70m 2.2D, 3.0 V6 (JEOD, JEOE, JEOH, JEOP)	96- 02		334960					553219		
=2.87m 2.2D, 3.0 V6 (JEOD, JEOE, JEOH, JEOP)	96- 02		334960							
=2.70 m 2.0, 1.9D, 2.2D, 3.0 V6 (JEOA, JEOD, JEOE, JEOH, JEOM, JEON, JEOP)	96- 02		334960					553218		
= 2.87 m 2.0, 2.2D, 3.0 V6 (JEOA, JEOE, JEOH, JEON, JEOP)	96- 02		334960							
= 2.70 m 3.0 V6 (JEOG)	96- 02		OE= 60 25 314 853/854					553218		
= 2.87 m 3.0 V6 (JEOG)	96- 02		OE= 60 25 314 853/854					OE= 60 25 314 022		
= 2.70 m 3.0 V6 (JEOG)	96- 02		OE= 60 25 314 853/854					OE= 60 25 314 020		
 Exc.  Self Leveling (K)	02-	634814						344802		

\*Excel-G is a new name of SUPER  
 Excel-G ist der neue Name für SUPER  
 Excel-G est le nom nouveau pour SUPER

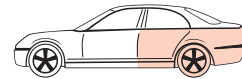
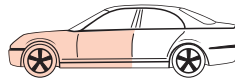

MODEL FAHRZEUG MODELE	YEAR JAHR ANNEE	FRONT/VORNE/AVANT				REAR/HINTEN/ARRIERE			
		PREMIUM Oil	EXCEL-G* Twin-tube Gas	GAS-A-JUST Mono-tube Gas		PREMIUM Oil	EXCEL-G* Twin-tube Gas	GAS-A-JUST Mono-tube Gas	

## Renault (F)

### Fuego

TL, GTL, GTS, GTX (R-1360/1361/1362/1363/1365/1366)	80- 85	441052	341047		$\frac{1}{\otimes}$ 1,6	443206	343180	553150	$\frac{1}{\oplus}$ 1,4
--	--------	--------	--------	--	----------------------------	--------	--------	--------	---------------------------

**Kangoo** ⇒ See Renault Commercial (F)

**Laguna** Exc.

1.8 (B56A, B56B, B56S, B56Z) 2.0 (B56C, B56H, B56N) Exc. 2.0S	1) 12.93- 4.95	634802 <sup>2)</sup>	334802 <sup>2)</sup>		$\oplus\oplus$ 1,7			551062▼ 551805	$\ominus$ $\ominus$ 0,7
1.8 (B56A, B56B, B56S, B56T, B56Z)	1) 4.95- 3.01	634802 <sup>2)</sup>	334802 <sup>2)</sup>		$\oplus\oplus$ 1,7			551062▼ 551805	$\ominus$ $\ominus$ 0,7
1.8 (B560, B56B, B56S, B56T)	1) 4.95- 3.01	634802 <sup>2)</sup>	334802 <sup>2)</sup>		$\oplus\oplus$ 1,7			551062▼ 551805	$\ominus$ $\ominus$ 0,7
1.8 (B560, B56B, B56S, B56T)	1) 4.95- 3.01	634807 <sup>3)</sup>	334807 <sup>3)</sup>		$\oplus\oplus$ 1,7			551062▼ 551805	$\ominus$ $\ominus$ 0,7

1)

	Model Type	-4.95	4.95-
1800 cc	B 560		S000001 →, E000001 →
	B 56A	→ S023509	S023510 →, E000001 →
	B 56B	→ S060991, → E060293	S060992 →, E060294 →
	B 56S	→ S003274, → E012489	S003275 →, E012490 →
	B 56T		S000001 →, E000001 →
	B 56Z	→ S000011	S000012 →, E000001 →
2000 cc	B 56C	→ S059001, → E036671	S059002 →, E036672 →
	B 56H	→ S010453	S010454 →, E000001 →
	B 56L		S000001 →, E000001 →
	B 56N	→ S001608	S001609 →, E000001 →

12.93- 06.96

ID Plate

07.96-

Fabrication No.

= W

= Exc.W

Fabrication No.

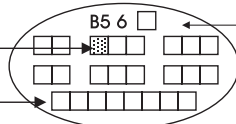

= D

= C, E

A = Normal Road

B = Bad Road

2), 3)

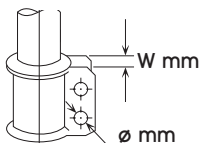

	ø	W	KYB
2)	16 mm	34 mm	634802, 334802
3)	14 mm	24 mm	634807, 334807



MODEL FAHRZEUG MODELE	YEAR JAHR ANNEE	FRONT/VORNE/AVANT				REAR/HINTEN/ARRIERE			
		PREMIUM Oil	EXCEL-G* Twin-tube Gas	GAS-A-JUST Mono-tube Gas		PREMIUM Oil	EXCEL-G* Twin-tube Gas	GAS-A-JUST Mono-tube Gas	

## Renault (F)

### Laguna Exc.

2.0 Exc. 2.0S (B56C, B56L) (B56C) , , (B56C) , (B56H) (B56H)  ABS (B56L) , (B56L) ,   ABS (B56N) (B56N)	1) 4.95- 3.01	634802 <sup>2)</sup>	334802 <sup>2)</sup>	 1,7			551062▼ 551805	 0,7
2.0 Exc. 2.0S (B56C) , , , (B56H) , (B56L) , , , (B56L)   ABS	1) 4.95- 3.01	634807 <sup>3)</sup>	334807 <sup>3)</sup>	 1,7			551062▼ 551805	 0,7
2.0S (B56D, B56M) 2.2 D/TD (B562, B566, B569, B56F) 3.0 (B56E, B56R)	12.93- 3.01	634802 <sup>2)</sup>	334802 <sup>2)</sup>	 1,7			551062▼ 551805	 0,7

1)

	Model Type	-4.95	4.95-
1800 cc	B 560		S000001 →, E000001 →
	B 56A	→ S023509	S023510 →, E000001 →
	B 56B	→ S060991, → E060293	S060992 →, E060294 →
	B 56S	→ S003274, → E012489	S003275 →, E012490 →
	B 56T		S000001 →, E000001 →
	B 56Z	→ S000011	S000012 →, E000001 →
2000 cc	B 56C	→ S059001, → E036671	S059002 →, E036672 →
	B 56H	→ S010453	S010454 →, E000001 →
	B 56L		S000001 →, E000001 →
	B 56N	→ S001608	S001609 →, E000001 →

12.93- 06.96

ID Plate

07.96-

Fabrication No.

= W  
, = Exc.W  
Fabrication No. →

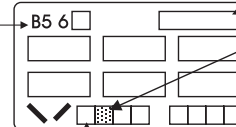
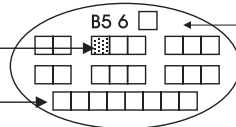

= D  
, = C, E

2), 3)

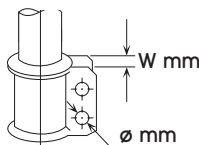

	ø	W	KYB
2)	16 mm	34 mm	634802, 334802
3)	14 mm	24 mm	634807, 334807

A = Normal Road  
B = Bad Road

### Laguna Exc.

	95- 3.01	634802	334802	 1,7			551067▼ 551808	 0,7
							Exc.	
	12.93- 3.01		334802	 1,7			551067▼ 551808	 0,7
							Exc.	

\* Excel-G is a new name of SUPER  
Excel-G ist der neue Name für SUPER  
Excel-G est le nom nouveau pour SUPER

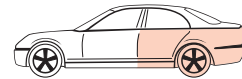
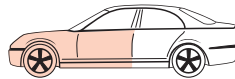

MODEL FAHRZEUG MODELE	YEAR JAHR ANNEE	FRONT/VORNE/AVANT				REAR/HINTEN/ARRIERE			
		PREMIUM Oil	EXCEL-G* Twin-tube Gas	GAS-A-JUST Mono-tube Gas		PREMIUM Oil	EXCEL-G* Twin-tube Gas	GAS-A-JUST Mono-tube Gas	
<b>Renault (F)</b>									
<b>Laguna II</b>									
1.6, 1.8, 2.0, 1.9dCi (B74)	2.01-	633717						553803	
1.6, 1.8, 2.0, 1.9dCi (K74)	2.01-	633717						553803	
<b>Mégane, Mégane Classic  , </b>									
Exc. 2.0-16V,	95- 9.02	633827	333827 <u>323827</u> SM1501					551061▼ 551804 <u>241011</u>	
2.0-16V Exc.	95- 9.02		334808 <u>324808</u> SM1501					551065 <u>241012</u>	
Mégane II 	10.02-	633718					344800		
<b>Mégane, Mégane Coach  , </b>									
Exc. 2.0-16V	95- 03	633827	333827 <u>323827</u> SM1501					551065 <u>241012</u>	
2.0-16V	95- 03		334808 <u>324808</u> SM1501					551065 <u>241012</u>	
<b>Mégane Grandtour </b>									
	1.97- 03	633827	333827 <u>323827</u>					555013	
<b>Mégane Scenic  (2WD)</b>									
1.4, 1.6	96- 9.98	633827	333827 SM1501			1.7		551066▼ 551807	
1.6 1.9D, 1.9DT 1.9DTI, 2.0	96- 6.98	634929	334929 SM1501			1.7		551066▼ 551807	
1.4, 1.6 1.6 , 1.9D, 1.9DT, 1.9DTI, 2.0	10.98- 03 7.98- 03	633827	333827 SM1501			1.7		551066▼ 551807	



MODEL FAHRZEUG MODELE	YEAR JAHR ANNEE	FRONT/VORNE/AVANT				REAR/HINTEN/ARRIERE			
		PREMIUM Oil	EXCEL-G* Twin-tube Gas	GAS-A-JUST Mono-tube Gas		PREMIUM Oil	EXCEL-G* Twin-tube Gas	GAS-A-JUST Mono-tube Gas	
<b>Renault (F)</b>									
<b>R 4</b>									
(R-1120/1124)	61- 8.68					441004		551045	
(R-1120/1123/1126)	9.68-	443032	343022			441004		551045	
GTL (R-1128)	78-	443032	343022			441004		551045	
(F 4) (R-2105/2106/2109)	9.68-	443032	343022					551029	
(F 6) (R-2430/2370)	75-	443032	343022					551029	
<b>R 5</b>									
 Incl. Soci�t� Exc. Alpine, Turbo (R-1223/122B)	2.72- 84	443032	343022	553076		441030	341005	551023	
Alpine (R-1223) Alpine Turbo (R-122B)	76- 84								
<b>R 5 (Super 5) </b>									
B 40, C 40, S 40 Exc. GT Turbo	84- 7.85	633080	333059			441056	341058	551046	
				SM1500	3,0				
B 40, C 40, S 40 Exc. GT Turbo, GTE	8.85- 5.88	633804 <sup>1)</sup>	333804 <sup>1)</sup>			441056	341058	551046	
				SM1500	3,0				
B 40, C 40, S 40 Exc. B/C 402, 408, 40G, 40K, S400 Exc. GT Turbo, Diesel	6.88-	633805 <sup>2)</sup>	333805 <sup>2)</sup>			441056	341058	551046	
				SM1500	3,0				
B402, C402, S400, B408, C408, B40G, C40G, B40K, C40K	6.88-	633804 <sup>1)</sup>	333804 <sup>1)</sup>			441056	341058	551046	
				SM1500	3,0				
Diesel (B/C/S 404) TD, GTD	6.88-	633804 <sup>1)</sup>	333804 <sup>1)</sup>			441056	341058	551046	
				SM1500	3,0				
GT Turbo (C 405)	84- 8.85	633081	333060				341068		
				SM1500	3,0				
<p>1) 633804 333804</p> <p>2) 633805 333805</p>									

\*Excel-G is a new name of SUPER  
 Excel-G ist der neue Name f r SUPER  
 Excel-G est le nom nouveau pour SUPER

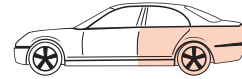
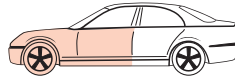

MODEL FAHRZEUG MODELE	YEAR JAHR ANNEE	FRONT/VORNE/AVANT				REAR/HINTEN/ARRIERE			
		PREMIUM Oil	EXCEL-G* Twin-tube Gas	GAS-A-JUST Mono-tube Gas		PREMIUM Oil	EXCEL-G* Twin-tube Gas	GAS-A-JUST Mono-tube Gas	
<b>Renault (F)</b>									
<b>R 5 (Super 5) </b>									
GT Turbo (C 405) GTE (C 409)	9.85- 5.87 10.86-	633082	333061				341068		
			SM1500		3,0				
GT Turbo (C 405)	6.87-						341068		
			SM1500						
<b>R 5 (Super 5) Express, Rapide, Extra  =&gt; See Renault Commercial (F)</b>									
<b>R 6</b>									
 (R-1180, 1181)	68- 81	443032				441004			
					1,6				1,2
<b>R 9, R 11</b>									
R 9  2x	82- 90	633807	333807				343152	553141	
1.1 (L 421)									
1.2 (L 42S)			945502	SM1501	3,0				0,7
1.4 (L 422/423/42A/42C/42R)									
1.6 D (L 424)									
Exc.1.4 Turbo (L 425)									
R 11  2x	83- 90	633807	333807				343152	553141	
1.1 (B/C/S 371)									
1.2 (B/C/S 37S)			945502	SM1501	3,0				0,7
1.4 (B/C 372/373/37A/37C/37R)									
1.4 (S 372/373/37A)									
1.6 D (B/C/S 374)									
Exc.1.4 Turbo (B/C 375)									
R 9  2x	85- 86	633807	333807				343152	553141	
1.7 (L 426)  → D003950/→ H005600									
1.7 (L 42F)  → D000525			945502	SM1501	3,0				0,7
R 11  2x	84- 86	633807	333807				343152	553141	
1.4 Turbo (B 375)  → D001343									
1.4 Turbo (C 375)  → D007886			945502	SM1501	3,0				0,7
1.4 Turbo (C 375)  → E002300									
1.7 (B 376)  → D043789/→ H017726									
1.7 (B 37F)  → D000644									
1.7 (C 376)  → D006418									
1.7 (C 37F)  → D000509									
R 9  4x	86- 90	633807	333807				343207		
1.7 (L 426)  D003951 →/H 005601 →									
1.7 (L 42F)  D000526 →			945502	SM1501	3,0				0,7
R 9  4x	85- 90	633807	333807				343207		
1.7 (L 42D/42E/42L/42N)									
1.4 Turbo (L 425)			945502	SM1501	3,0				0,7
R 11  4x	86- 90	633807	333807				343207		
1.4 Turbo (B 375)  D001344 →									
1.4 Turbo (C 375)  D007887 →			945502	SM1501	3,0				0,7
1.4 Turbo (C 375)  E002301 →									
1.7 (B 376)  D043790 →/H017727 →									
1.7 (B 37F)  D000645 →									
1.7 (C 376)  D006419 →									
1.7 (C 37F)  D000510 →									

\*Excel-G is a new name of SUPER  
Excel-G ist der neue Name für SUPER  
Excel-G est le nom nouveau pour SUPER





MODEL FAHRZEUG MODELE	YEAR JAHR ANNEE	FRONT/VORNE/AVANT				REAR/HINTEN/ARRIERE			
		PREMIUM Oil	EXCEL-G* Twin-tube Gas	GAS-A-JUST Mono-tube Gas		PREMIUM Oil	EXCEL-G* Twin-tube Gas	GAS-A-JUST Mono-tube Gas	
<b>Renault (F)</b>									
<b>R 9, R 11</b>									
R 11  4x(⊖) ⊕ 1.7 (B/C 37D/37E/37L/37N)	86- 90	633807	333807		⊕		343207		⊥ ⊖ 0,7
				SM1501	3,0				
<b>R 12, R 15, R 17</b>									
R 12 (R-1170/1171/1177/1330) R 15 TL, TS, GTL (R-1300/1302) R 17 TL, TS (R-1312/1317/1322/1327)	70- 79 72- 79 71- 79	441013	341019		⊥ ⊗ 1,6	444031		554028	⊥ ⊥ 1,6
<b>R 14</b>									
TL, GTL (R-1210)  →345946 LS, TS (R-1211)  →7533	5.76- 78	664004	364008		⊥ 4,0	441030	341005	551023	⊥ ⊖ 1,0
TL, GTL (R-1210/1213)  345947→ LS, TS (R-1211/1212)  7534→	78- 83	664009			⊥ 4,0	441030	341005	551023	⊥ ⊖ 1,0
<b>R 18 </b>									
TL, GTL (R-1340)  →552000 TS, GTS (R-1341)  →559400 TS, GTS (R-1342)  →20609	79- 84 79- 84 79- 83	441049	341076		⊥ ⊗ 1,6	443205	343179	553149	⊥ ⊥ 1,4
TX, GTX (R 1343)  →3200 TD, GTD(R 1344)  →190905	- 83 80- 84	441051	341046		⊥ ⊗ 1,6	443205	343179	553149	⊥ ⊥ 1,4
TL, GTL (R 1340)  552001→ TS, GTS (R 1341)  559401→ TS, GTS (R 1342)  20610→ TX, GTX (R 1343)  3201→ TD, GTD (R 1344)  190906→ Turbo (R 1345)  = Turbo Diesel (R 1346)  =	84- 86 84- 86 83- 86 84- 86 84- 86 82- 86 84- 86	441052	341047		⊥ ⊗ 1,6	443205	343179	553149	⊥ ⊥ 1,4
<b>R 18 Break  (2WD)</b>									
TL (R 1350)  →122600 TS, LS, GTL (R 1351)  →118200 GTS (R 1352)  →3929 Société (R 2350)  →4600	79- 84 79- 84 82- 83 - 80	441049	341076		⊥ ⊗ 1,6	443206	343180	553150	⊥ ⊥ 1,4
TX, GTX (R 1353)  →2000 TD, GTD (R 1354)  →63219 Société (R 2354)  →3499	- 82 - 84 - 83	441051	341046		⊥ ⊗ 1,6	443206	343180	553150	⊥ ⊥ 1,4
TL (R 1350)  122601→ TS, LS, GTL (R 1351)  118201→ GTS (R 1352)  3930→ TX, GTX (R 1353)  2001→ TD, GTD (R 1354)  63220→ Turbo (R 1355)  = Turbo Diesel (R 1356)  = Société (R 2350)  4601→ Société (R 2354)  3500→	84- 86 84- 86 83- 86 83- 86 84- 86 83- 86 84- 86 84- 86 83- 86	441052	341047		⊥ ⊗ 1,6	443206	343180	553150	⊥ ⊥ 1,4

\*Excel-G is a new name of SUPER  
Excel-G ist der neue Name für SUPER  
Excel-G est le nom nouveau pour SUPER



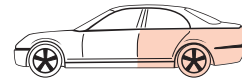
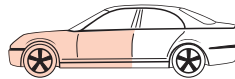

MODEL FAHRZEUG MODELE	YEAR JAHR ANNEE	FRONT/VORNE/AVANT				REAR/HINTEN/ARRIERE			
		PREMIUM Oil	EXCEL-G* Twin-tube Gas	GAS-A-JUST Mono-tube Gas		PREMIUM Oil	EXCEL-G* Twin-tube Gas	GAS-A-JUST Mono-tube Gas	
<b>Renault (F)</b>									
<b>R 19/Chamade</b>									
R 19/Chamade  2 x B/C/S/L 530, 532, 534, 537 B/C/L 53 A, 53 B, 53 P, 53 J, 53 I B/C 53 E, L 536	9.88- 95	633808	333808 <u>323808</u>		 ⊕ 2,2		343233 <sup>1)</sup>	553166 <sup>1)</sup> <u>243035</u> <sup>1)</sup>	 ⊕ 0,7
			SM1501						
R 19/Chamade  4 x B/C/L 53 C, 53 F, 533 B/C 53 M, D 53 C	9.88- 95	633808	333808 <u>323808</u>		 ⊕ 2,2		343234 <sup>2)</sup>	553167 <sup>2)</sup> <u>243036</u> <sup>2)</sup>	 ⊕ 0,7
			SM1501						
R 19/ Chamade 1.8-16V (B/C/L 539, 53 D, D 53 D)	9.88- 95							553167 <u>243036</u>	 ⊕ 0,7
			SM1501						
<div style="display: flex; justify-content: space-around;"> <div style="text-align: center;"> <p>1) </p> <p>L max. = 524mm</p> </div> <div style="text-align: center;"> <p>2) </p> <p>L max. = 563mm</p> </div> </div>									
<b>R 20, R 30</b>									
R 20 TL, GTL, TD, GTD, LS, TS (R 1271/1270/1276/1277) R 30 Turbo Diesel	81- 84 82- 84	441050	341045		 ⊕ 1,8		661006 634931	361006 334931	 ⊕ 1,6
R 20 LS, TS (R 1272) R 20 TX (R 1279) R 30 TX (R 1278)	78- 84 81- 84 80- 84				 ⊕ 1,8		661006 634931	361006 334931	 ⊕ 1,6
<b>R 21</b>									
 1.4 (L48D, B48D) 1.7 (L48 1/2/E/F/M/N, B48 1/2/E/F) 1.9 D (L48 H/I, B48H/I)	86- 94	631004	331002		 ⊕ 3,0		441057	341100	551047 ⊕ 0,7
			SM1502 ▼ SM1508						



MODEL FAHRZEUG MODELE	YEAR JAHR ANNEE	FRONT/VORNE/AVANT				REAR/HINTEN/ARRIERE			
		PREMIUM Oil	EXCEL-G* Twin-tube Gas	GAS-A-JUST Mono-tube Gas		PREMIUM Oil	EXCEL-G* Twin-tube Gas	GAS-A-JUST Mono-tube Gas	

## Renault (F)

### R 21 (2WD)

2.0 (L483, L48C, L48R), 2.2 (L48K) 2.1 D (L486, L480, L48V)	86- 94	635901 L 635900 R	335901 L 335900 R		441057	341100	551047	
			SM1502▼ SM1508 <sup>1)</sup> SM1509 <sup>1)</sup> SM1510 <sup>1)</sup>	3,0				
2.0 (L483, L48C, L48R), 2.2 (L48K) 2.1 D (L486, L480, L48V)	86- 94	635903 L 635902 R	335903 L 335902 R		441057	341100	551047	
			SM1502▼ SM1508 <sup>1)</sup> SM1509 <sup>1)</sup> SM1510 <sup>1)</sup>	3,0				
2.0 (L48Q, L48Y) 2.1 D (L480, B48 0/6/O/V) 2.1 TD (L48 7/8/A/P/W) Exc. 2.0 Turbo (L48 5/L)	86- 94	635903 L 635902 R	335903 L 335902 R		441057	341100	551047	
			SM1502▼ SM1508 <sup>1)</sup> SM1509 <sup>1)</sup> SM1510 <sup>1)</sup>	3,0				
2.0 (B48 3/C/R/Y), 2.2 (B48K) 2.1 TD (B48 7/8/A/P/W)	86- 94	635903 L 635902 R	335903 L 335902 R			341100	551047	
			SM1502▼ SM1508 <sup>1)</sup> SM1509 <sup>1)</sup> SM1510 <sup>1)</sup>	3,0				

1)	Model	Year	KYB
2.0	B48K / B48Y / B483 K48B / K48R / K48S / K489 L48Q / L48S / L48Y	86 -	SM1509
2.0	B48C / B48R K48C / L48C / L48K ⊖ ⊕	86 -	SM1508
2.0	B48C / B48R K48C / L48C / L48K ⊕ ⊕	86 -	SM1509
2.0	K48K / K483 L48K / L48R / L483 / L489	86 - 4.89	SM1508
2.0	K48K / K483 L48K / L48R / L483 / L489	5.89 -	SM1509
2.0 Turbo	L48 / L485	7.87 -	SM1510
2.1 D / TD	B48A / B48P / B48W / B480 / B486 / B487 / B488 K48A / K48P / K48W / K480 / K487 L48A / L48P / L48W / L480 / L487	86 -	SM1509
2.1 D / TD	B480 / B48V ⊖ ⊕ K480 / K48V ⊖ ⊕ S480 / S48V / S486 ⊖ ⊕	86 -	SM1508
2.1 D / TD	B480 / B48V ⊕ ⊕ K480 / K48V ⊕ ⊕ L480 / S480 / S48V / S486 ⊕ ⊕	86 -	SM1509
2.1 D / TD	K486 / K488 L48V / L486 / L488	86 - 4.89	SM1508
2.1 D / TD	K486 / K488 L48V / L486 / L488	5.89 -	SM1509

### R 21 Nevada, Société (2WD)

1.7 (K48 1/2/E/F/M/N, S481, S482) 1.9 D (K48 H/I, S48 H)	86-	631004	331002			341964		
			SM1502▼ SM1508	3,0				

\*Excel-G is a new name of SUPER  
Excel-G ist der neue Name für SUPER  
Excel-G est le nom nouveau pour SUPER

= **ULTRASR**

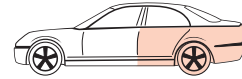
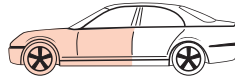

MODEL FAHRZEUG MODELE	YEAR JAHR ANNEE	FRONT/VORNE/AVANT				REAR/HINTEN/ARRIERE			
		PREMIUM Oil	EXCEL-G* Twin-tube Gas	GAS-A-JUST Mono-tube Gas		PREMIUM Oil	EXCEL-G* Twin-tube Gas	GAS-A-JUST Mono-tube Gas	

## Renault (F)

### R 21 Nevada, Société (2WD)

⊕ ⊕ 2.0 (K483, K48C), 2.2 (K48K) 2.1D (K48 6/O/V, S48V)	86-	635901 L 635900 R	335901 L 335900 R		3,0	341964	⊖ ⊖ 0,7
Société 2.1 D (S486, S48O)	86-	635901 L 635900 R	335901 L 335900 R		3,0	341964	⊖ ⊖ 0,7
⊕ ⊕ 2.0 (K48 3/C), 2.2 (K48K) 2.1D (K48 6/O/V, S48V)	86-	635903 L 635902 R	335903 L 335902 R		3,0	341964	⊖ ⊖ 0,7
2.0 (K48R), 2.2 (K48B) 2.1D (K48O) 2.1 TD (K48 7/8/A/P/W)	86-	635903 L 635902 R	335903 L 335902 R		3,0	341964	⊖ ⊖ 0,7

1)

	Model	Year	KYB
2.0	B48K / B48Y / B483 K48B / K48R / K48S / K489 L48Q / L48S / L48Y	86 -	SM1509
2.0	B48C / B48R K48C / L48C / L48K ⊖ ⊕	86 -	SM1508
2.0	B48C / B48R K48C / L48C / L48K ⊕ ⊕	86 -	SM1509
2.0	K48K / K483 L48K / L48R / L483 / L489	86 - 4.89	SM1508
2.0	K48K / K483 L48K / L48R / L483 / L489	5.89 -	SM1509
2.0 Turbo	L48 / L485	7.87 -	SM1510
2.1 D / TD	B48A / B48P / B48W / B480 / B486 / B487 / B488 K48A / K48P / K48W / K480 / K487 L48A / L48P / L48W / L480 / L487	86 -	SM1509
2.1 D / TD	B480 / B48V ⊖ ⊕ K480 / K48V ⊖ ⊕ S480 / S48V / S486 ⊖ ⊕	86 -	SM1508
2.1 D / TD	B480 / B48V ⊕ ⊕ K480 / K48V ⊕ ⊕ L480 / S480 / S48V / S486 ⊕ ⊕	86 -	SM1509
2.1 D / TD	K486 / K488 L48V / L486 / L488	86 - 4.89	SM1508
2.1 D / TD	K486 / K488 L48V / L486 / L488	5.89 -	SM1509

### R 25 Exc.

 Incl. V 6, Diesel Turbo	11.83- 92	441058	341109		3,4	634909	334909		1,8
-----------------------------	-----------	--------	--------	--	-----	--------	--------	--	-----



MODEL FAHRZEUG MODELE	YEAR JAHR ANNEE	FRONT/VORNE/AVANT				REAR/HINTEN/ARRIERE			
		PREMIUM Oil	EXCEL-G* Twin-tube Gas	GAS-A-JUST Mono-tube Gas		PREMIUM Oil	EXCEL-G* Twin-tube Gas	GAS-A-JUST Mono-tube Gas	
<b>Renault (F)</b>									
<b>Safrane I &amp; II</b> <b>Exc.</b>									
Safrane I Safrane II	92- 96 96-		334911 L 334910 R		 3,0		334912		 4,0
<b>Twingo</b>									
1.1, 1.2 (C/S 063, 064, 065, 066, 067, 068)	93-		333911 ▼ 333714		 2,2		341906 ▼ 341813		 1,4
<b>VelSatis</b>									
	02-	634814					344801		
<b>Renault Commercial (F)</b>									
<b>Kangoo</b>									
(FC0 Series) Exc. Cu +,	97-	633848	333848					551072 <sup>1)</sup> ▼ 551810 <sup>1)</sup>	
		OE = 7700 311 596, 7700 314 021							
		SM1507							
Cu +  (FC0 Series) Exc.	97-	633848	333848					551073 <sup>2)</sup> ▼ 551811 <sup>2)</sup>	
		OE = 7700 311 597, 7700 314 022							
		SM1507							
(FC0 Series) 	97-							551073 <sup>2)</sup> ▼ 551811 <sup>2)</sup>	
		OE = 7700 311 598, 7700 314 023							
		SM1507							
1)  Ø 40 mm      2)  Ø 50 mm									
<b>Master Q Series</b>									
	81- 98	441965						551071	
<b>Master R Series</b>									
 → B066692	81- 2.89	441965							
 B066693 →	3.89- 97	441966							

\* Excel-G is a new name of SUPER  
 Excel-G ist der neue Name für SUPER  
 Excel-G est le nom nouveau pour SUPER

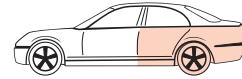
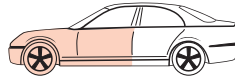

MODEL FAHRZEUG MODELE	YEAR JAHR ANNEE	FRONT/VORNE/AVANT				REAR/HINTEN/ARRIERE			
		PREMIUM Oil	EXCEL-G* Twin-tube Gas	GAS-A-JUST Mono-tube Gas		PREMIUM Oil	EXCEL-G* Twin-tube Gas	GAS-A-JUST Mono-tube Gas	

## Renault Commercial (F)

### Master R Series

ALL	81- 2.89							553213 <sup>1)</sup>	
ALL	3.89- 97							553214 <sup>1)</sup>	
RC7*, RL7*	81- 97							551071 <sup>1)</sup>	
Exc.  RC9*, RD9*, RL9*	81- 94							551071 <sup>1)</sup>	
Exc.  RC9*, RD9*, RL9*	94- 97							553214 <sup>1)</sup>	
RH9*, RJ9*	81- 2.89							553213 <sup>1)</sup>	
RH9*, RJ9*	3.89- 97							553214 <sup>1)</sup>	
	81- 97							553215 <sup>1)</sup> 553216 <sup>1)</sup>	

1)		OE =	KYB =
		5005 387 175 5000 388 797	553213
		7700 748 642 6006 000 216	553214
		5000 393 469 5000 393 763	553215
		5000 394 656 5000 395 444 6006 000 217	553216
		6006 000 215	551071

### Master

2.5 D 2.8 TD	9.97-		344306						
1.9 DTi 2.2 DCi	9.00-		344306						



MODEL FAHRZEUG MODELE	YEAR JAHR ANNEE	FRONT/VORNE/AVANT				REAR/HINTEN/ARRIERE			
		PREMIUM Oil	EXCEL-G* Twin-tube Gas	GAS-A-JUST Mono-tube Gas		PREMIUM Oil	EXCEL-G* Twin-tube Gas	GAS-A-JUST Mono-tube Gas	
<b>Renault Commercial (F)</b>									
<b>Master </b>									
ED*	9.97-						344307		
FD*  ,	9.97-						344307		
JD*  ,	9.97-						344307		
FD0* , FD2B, FD2E, FD3*	9.97-						344307		
HD, UD	9.97-								
<b>R 5 (Super 5) Express, Rapide, Extra </b>									
(F 40 Series) Exc. Cu +	10.85-10.96	633806 <sup>1)</sup>	333806 <sup>1)</sup>		441064 <sup>3)</sup>	341115 <sup>3)</sup>			
				3,0					0,7
Cu +  (F 40 Series) 	10.85-10.96	633806 <sup>1)</sup>	333806 <sup>1)</sup>				551077 <sup>4)</sup>		
				3,0					0,7
(F 40 Series) Exc. Cu +	10.96-	633847 <sup>2)</sup>	333847 <sup>2)</sup>		441064 <sup>3)</sup>	341115 <sup>3)</sup>			
									0,7
Cu +  (F 40 Series) 	10.96-	633847 <sup>2)</sup>	333847 <sup>2)</sup>				551077 <sup>4)</sup>		
									0,7
<p>1) 633806 333806 </p> <p>2) 633847 333847 </p> <p>3) </p> <p>4) </p>									
<b>Traffic T Series  </b>									
T1**  Exc.	81- 2.89	635909 L 635908 R			444155				
T3**  Exc.									
T4**  Exc.  , High-Roof									
T1**	81- 2.89				444156				
T4**									
High-Roof T42*, T44*, T46*, T4C* → 25720	81-12.82	635909 L 635908 R			444155				
High-Roof T42*, T44*, T46*, T4C* 25721 →	1.83- 2.89	635913 L 635912 R			444155				
T2**, T5**, T6**, T7**, T9** TA**, TB**, TE**	81- 2.89	635909 L 635908 R			444156				

\*Excel-G is a new name of SUPER  
Excel-G ist der neue Name für SUPER  
Excel-G est le nom nouveau pour SUPER

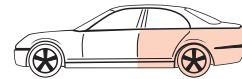
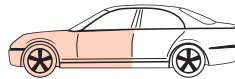

MODEL FAHRZEUG MODELE	YEAR JAHR ANNEE	FRONT/VORNE/AVANT				REAR/HINTEN/ARRIERE			
		PREMIUM Oil	EXCEL-G* Twin-tube Gas	GAS-A-JUST Mono-tube Gas		PREMIUM Oil	EXCEL-G* Twin-tube Gas	GAS-A-JUST Mono-tube Gas	
<b>Renault Commercial (F)</b>									
<b>Traffic T Series (2WD)</b>									
T1**, T2**, T3**, T4** TG**, TH**, TJ**	3.89- 8.01	635909 L 635908 R				444155			
T7** TB**, TE**, TM**	3.89- 8.01	635909 L 635908 R				444156			
T5**	3.89- 8.01	635909 L 635908 R				444155 <sup>1)</sup> 444156 <sup>2)</sup>			
TC**	3.89- 8.01	635909 L 635908 R							
<b>Traffic P Series (2WD)</b>									
P3** → 3373	81- 82	635909 L <sup>3)</sup> 635908 R <sup>4)</sup>							
P3** 3374 →	82- 2.89	635909 L <sup>3)</sup> 635908 R <sup>4)</sup>				444900			
P3**	3.89- 8.01	635911 L <sup>5)</sup> 635910 R <sup>6)</sup>				444900			
P5**  → 224 P64*  → 105	81- 82 81- 82	635909 L 635908 R							
P5**  225 → P64*  106 → P8**	82- 8.01 82- 8.01 81- 89	635909 L 635908 R				444900			
P6C* PA**, PC**	81- 89 81- 8.01	635913 L 635912 R				444900			
<div style="display: flex; justify-content: space-between;"> <div style="width: 30%;"> <p>1) </p> </div> <div style="width: 30%;"> <p>2) </p> </div> <div style="width: 30%;"> <p>3) OE = 7700 718 591 4) OE = 7700 718 592 5) OE = 7700 717 625 6) OE = 7700 717 626</p> </div> </div>									
<b>Traffic V Series (4WD)</b>									
V2**, V3**, V4**, V5**, V9**	85- 8.01	635913 L 635912 R				444900			





MODEL FAHRZEUG MODELE	YEAR JAHR ANNEE	FRONT/VORNE/AVANT				REAR/HINTEN/ARRIERE			
		PREMIUM Oil	EXCEL-G* Twin-tube Gas	GAS-A-JUST Mono-tube Gas		PREMIUM Oil	EXCEL-G* Twin-tube Gas	GAS-A-JUST Mono-tube Gas	
<b>Renault Commercial (F)</b>									
<b>Traffic II</b>									
	9.01-		335803 O.E.=8200 212 833		+		344803 O.E.=8200 046 851		
<b>Rover (GB)</b>									
<b>100 Series</b>									
114	(XP)	90-	442031	342016					
<b>200 Series </b>									
213, 216 series	(SD 3)	84- 89	633056 L 633055 R	333031 L 333030 R		+	441054	341050	
						1,0			
214	(XW)	89- 96	634041 L 634040 R	334069 L 334068 R		+	441082	341131	
216  Exc. 216 GTi						1,0			
216 GTi	(XW)	89- 96		334069 L 334068 R		+		341131	
220  Incl. 220 GTi						1,0			
218 Diesel (1.9D)	(XW)	89- 96	634067 L 634066 R	334104 L 334103 R		+	441082	341131	
218 Turbo Diesel (1.7 TD)						1,0			
214, 216, 220 D Incl. Si, SD, SDi	(RF)	96- 3.00		334156		+		341208	
200 Vi	(RF)	96- 3.00				+		341208	
<b>200 Series </b>									
	(XW)	89- 2.96		334069 L 334068 R		+		341131	
Incl. 220 Turbo → 911247						1,0			
Incl. 220 Turbo 911248 →	(XW)	2.96-		334156		+			
<b>200 Series </b>									
214 → 911247	(XW)	92- 2.96	634041 L 634040 R	334069 L 334068 R		+	441082	341131	
						1,0			

\*Excel-G is a new name of SUPER  
 Excel-G ist der neue Name für SUPER  
 Excel-G est le nom nouveau pour SUPER

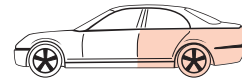
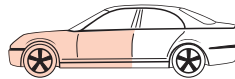

MODEL FAHRZEUG MODELE	YEAR JAHR ANNEE	FRONT/VORNE/AVANT				REAR/HINTEN/ARRIERE			
		PREMIUM Oil	EXCEL-G* Twin-tube Gas	GAS-A-JUST Mono-tube Gas		PREMIUM Oil	EXCEL-G* Twin-tube Gas	GAS-A-JUST Mono-tube Gas	
<b>Rover (GB)</b>									
<b>200 Series</b>									
216 → 911247	(XW)	92- 2.96	634067 L 634066 R	334104 L 334103 R			441082	341131	
					1,0				
 911248→	(XW)	3.96-		334156			441082	341131	
<b>400 Series</b>									
414, 416	(XW)	89- 95	634041 L 634040 R	334069 L 334068 R			441082	341131	
					1,0				
418 Diesel , 418 Turbo Diesel 420	(XW)	89- 95	634067 L 634066 R	334104 L 334103 R			441082	341131	
					1,0				
414, 416, 420, 420 D	(RT)	5.95- 3.00		341219 L 341218 R				341131	
<b>400 Series</b>									
414, 416 → 911247	(XW)	94- 2.96	634041 L 634040 R	334069 L 334068 R			441082	341131	
					1,0				
418 Diesel, 418 Turbo Diesel 420 → 911247	(XW)	94- 2.96	634067 L 634066 R	334104 L 334103 R			441082	341131	
					1,0				
 911248 →	(XW)	3.96- 3.00		334156			441082	341131	
<b>600 Series</b>									
	(RH)	93- 2.99		341172 L 341171 R				341173	
<b>800 Series</b>									
	(XS)	86- 8.91	441096	341155			633173 L 633172 R	333191 L 333190 R	
							Exc.		
	(RS)	11.91- 2.99	441097	341156			634065 L 634064 R	334102 L 334101 R	
							Exc.		
<b>Landrover</b>									
= 86" = 88" MK I & fire tender = 88" MK II, MK II A & MK III = 107" (Stat. Wagon) = 109" MK I		53- 6.56 56- 2.58 2.58- 53-11.58 53- 2.58	444042 H/D 445005				444043 H/D 445006		



MODEL FAHRZEUG MODELE	YEAR JAHR ANNEE	FRONT/VORNE/AVANT				REAR/HINTEN/ARRIERE			
		PREMIUM Oil	EXCEL-G* Twin-tube Gas	GAS-A-JUST Mono-tube Gas		PREMIUM Oil	EXCEL-G* Twin-tube Gas	GAS-A-JUST Mono-tube Gas	
<b>Rover (GB)</b>									
<b>Landrover</b>									
= 109" MK II MK II Staff car & fire tender W/D MK II A MK III	2.58- 8.61 58- 62 2.58- 9.71 9.71-	444042 H/D 445005				444044 H/D 445007			
= 109" F/C = 110" F/C = 109" MK II, raised frame, crash tender	11.62- 1.64 12.66- 1.72 60-	445008				445009			
Landrover 90 Landrover 110	84- 83-	445026	345014	555003			345005	555004	
Discovery (SALL****)  Exc.	89- 98	445037					345005	555004	
Discovery (SALL****)  SALL****WA →	99-	445035				445036			
Range Rover (SALLH****)  Exc.	6.70- 86	445002▼ 445037				445003▼ 445025	345013		
Range Rover (SALLH****)  → GA417084 Incl. Exc.	86- 91	445037				445025	345013		
Range Rover (SALLH****) → GA417084 Incl. Exc.	86- 91	445037					345005	555004	
Range Rover (SALLH****)  GA417085→ Incl. Exc.	86- 91	445037					345005	555004	
Range Rover Classic (SALLH****)  Exc.	92- 95	445037					345005	555004	
Range Rover Classic (SALLH****)  Exc.	92- 95	445038					345005	555004	
Range Rover Classic (SALLH****)  Incl.	92- 95	445037					345005	555004	
New Range Rover (SALLP****) 	95-	445042				445043			
<b>Austin, Morris, Mini, Sherpa, Maestro, Montego, Triumph ⇒ Austin- Rover Group (GB)</b>									

\*Excel-G is a new name of SUPER  
Excel-G ist der neue Name für SUPER  
Excel-G est le nom nouveau pour SUPER

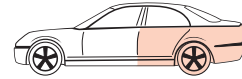
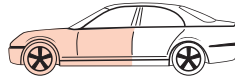

MODEL FAHRZEUG MODELE	YEAR JAHR ANNEE	FRONT/VORNE/AVANT				REAR/HINTEN/ARRIERE			
		PREMIUM Oil	EXCEL-G* Twin-tube Gas	GAS-A-JUST Mono-tube Gas		PREMIUM Oil	EXCEL-G* Twin-tube Gas	GAS-A-JUST Mono-tube Gas	
<b>Saab (S)</b>									
<b>9-3 (YS3D)  W-2 050001/W-7 050001 ⇒</b>									
ALL	98-		366012		□		343270	553194	⊥ ⊕
<b>9-5 (YS3E)</b>									
ALL Exc. Sport sus.	9.97-		335921		⊕			551917	⊥ ⊕
<b>90</b>									
ALL	84- 88		343008	553014	○ ○ 0,5		343024	551005	⊥ ⊕ 0,8
<b>95, 96, GT 750</b>									
95, 96, GT 750 	60- 79	443033	343083		○ ○ 0,5	443034	343084		⊥ ○ 0,8
95 	60- 78	443033	343083		○ ○ 0,5				
<b>99 </b>									
ALL Exc. Turbo	68- 4.78	443035	343008		○ ○ 0,5	443036	343009		⊥ ⊕ 0,8
Turbo	77- 4.78		343008		○ ○ 0,5		343009		⊥ ⊕ 0,8
ALL Exc. Turbo	5.78- 84	443035	343008	553014	○ ○ 0,5	443038	343024	551005	⊥ ⊕ 0,8
Turbo	5.78- 84		343008	553014	○ ○ 0,5		343024	551005	⊥ ⊕ 0,8
<b>900</b>									
ALL Exc. Turbo	5.78- 93	443037	343023	553015	⊥ ○ 0,5	443038	343024	551005	⊥ ⊕ 0,8
Turbo ALL	5.78- 93		343023	553015	⊥ ○ 0,5		343024	551005	⊥ ⊕ 0,8
 2.0, 2.0 Turbo, 2.3, 2.5-V6	9.93- 98		366010		□		343270	553194	⊥ ⊕
 2.0, 2.0 Turbo, 2.3, 2.5-V6	9.93- 98		366009		□		343270	553194	⊥ ⊕



MODEL FAHRZEUG MODELE	YEAR JAHR ANNEE	FRONT/VORNE/AVANT				REAR/HINTEN/ARRIERE			
		PREMIUM Oil	EXCEL-G* Twin-tube Gas	GAS-A-JUST Mono-tube Gas		PREMIUM Oil	EXCEL-G* Twin-tube Gas	GAS-A-JUST Mono-tube Gas	
<b>Saab (S)</b>									
<b>9000</b>									
ALL H1015470→ H8000556→ Exc. Sport, CS	87-		334029					553187 Exc.	
CS  ALL Exc. Sport	92-		334029					553187 Exc.	
<b>Santana (E)⇒ Suzuki (J)</b>									
<b>Seat (E)</b>									
<b>124, 1430</b>									
124, 1430 Incl. Sport	67-	443007	343072	553003		443008	343017	553004	
124, 1430	67-	443007	343072	553003		443123	343098	553005	
<b>127</b>									
ALL	71-	633002	333014			633003	333005		
<b>128</b>									
ALL	73-	633004	333013			633005	333015		
<b>131</b>									
Mirafiori 	74- 78	633006	333016			443008	343017	553004	
Mirafiori 	74- 78	633006	333016			443012	343076		
Super Mirafiori 	77-	633007	333017			443008	343017	553004	
<b>132</b>									
1600, 1800, 2000	72-	443013	343018	553006		443014	343019	554005	
<b>Alhambra</b>									
ALL Exc.	(7MS) 3.96-		334947				343319	553244	
			SM1704						

\* Excel-G is a new name of SUPER  
Excel-G ist der neue Name für SUPER  
Excel-G est le nom nouveau pour SUPER

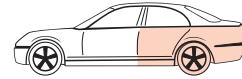
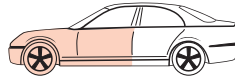

MODEL FAHRZEUG MODELE	YEAR JAHR ANNEE	FRONT/VORNE/AVANT				REAR/HINTEN/ARRIERE																																															
		PREMIUM Oil	EXCEL-G* Twin-tube Gas	GAS-A-JUST Mono-tube Gas		PREMIUM Oil	EXCEL-G* Twin-tube Gas	GAS-A-JUST Mono-tube Gas																																													
<b>Seat (E)</b>																																																					
<b>Alhambra</b>																																																					
	(7MS)	3.96-						343319	553244																																												
SM1704																																																					
<b>Arosa</b>																																																					
1.0, 1.4, 1.7 SDI	(6H)	97-	633950▼ 633712	333950▼ 333712 <u>324025</u>				343309																																													
SM1707																																																					
<b>Ibiza, Cordoba </b>																																																					
Ibiza 1.2, 1.5, 1.7 D		7.84- 7.86	633812	333812				633814	333814																																												
SM1804																																																					
					0,8					1,1																																											
Ibiza 1.2, 1.5, 1.7 D Junior SXi		8.86- 8.89 1.86- 8.89	633813	333813				633815	333815																																												
SM1705																																																					
					0,8					1,1																																											
Ibiza 0.9, 1.2, 1.5, 1.7 D Junior Sxi		9.89- 93	633840	333840				633815	333815																																												
SM1705																																																					
					0,8					1,1																																											
1.0, 1.05, 1.4 1.9SDI (50kw)	(6K, 6K/C)	93- 8.99	633950▼ 633712	333950▼ 333712 <u>324025</u>				443801 <sup>1)</sup>	343274 <sup>1)</sup>																																												
SM1701 <sup>2)</sup> SM1704 <sup>2)</sup>																																																					
					1,2				<u>353021</u> <sup>1)</sup>	1,1																																											
1.6, 1.8 1.9D, 1.9TD (47kw, 55kw) Exc. 1.8-16V, 1.9 TDI	(6K, 6K/C)	93- 8.99	633950▼ 633712	333950▼ 333712 <u>324025</u>				443801 <sup>1)</sup>	343274 <sup>1)</sup>																																												
SM1701 <sup>2)</sup> SM1704 <sup>2)</sup>																																																					
					1,2				<u>353021</u> <sup>1)</sup>	1,1																																											
1)		2)	<table border="1"> <thead> <tr> <th>Model</th> <th>Year</th> <th>KYB</th> </tr> </thead> <tbody> <tr> <td rowspan="8">IBIZA</td> <td>AAU / ABD / ABS / ADZ / 1Y / AAZ</td> <td>2.93 -12.95</td> <td>SM1701</td> </tr> <tr> <td>AAU / ABD / ADZ / 1Y / AAZ</td> <td>1.96 - 8.99</td> <td>SM1704</td> </tr> <tr> <td>ADL / 2E</td> <td>3.93 - 3.94</td> <td>SM1701</td> </tr> <tr> <td>ADL / 2E</td> <td>4.94 - 8.99</td> <td>SM1704</td> </tr> <tr> <td>1F / AEE</td> <td>3.93 - 4.96</td> <td>SM1701</td> </tr> <tr> <td>1F / AEE / AFT</td> <td>5.96 - 8.99</td> <td>SM1704</td> </tr> <tr> <td>AEX / AEY</td> <td>9.93 - 1.96</td> <td>SM1704</td> </tr> <tr> <td>AAV / ABU / 2G</td> <td>2.93 - 7.94</td> <td>SM1701</td> </tr> <tr> <td rowspan="5">CORDOBA</td> <td>ADB / 1F / ABU / ABS / 1Y / AAZ</td> <td>3.93 -12.95</td> <td>SM1701</td> </tr> <tr> <td>ABD / 1F / ADZ / 1Y / AEY</td> <td>96 - 6.99</td> <td>SM1704</td> </tr> <tr> <td>ADL / 2E</td> <td>10.93 - 4.94</td> <td>SM1701</td> </tr> <tr> <td>ADL / 2E</td> <td>5.94 - 6.96</td> <td>SM1704</td> </tr> <tr> <td></td> <td>7.96 - 6.99</td> <td>SM1704</td> </tr> </tbody> </table>							Model	Year	KYB	IBIZA	AAU / ABD / ABS / ADZ / 1Y / AAZ	2.93 -12.95	SM1701	AAU / ABD / ADZ / 1Y / AAZ	1.96 - 8.99	SM1704	ADL / 2E	3.93 - 3.94	SM1701	ADL / 2E	4.94 - 8.99	SM1704	1F / AEE	3.93 - 4.96	SM1701	1F / AEE / AFT	5.96 - 8.99	SM1704	AEX / AEY	9.93 - 1.96	SM1704	AAV / ABU / 2G	2.93 - 7.94	SM1701	CORDOBA	ADB / 1F / ABU / ABS / 1Y / AAZ	3.93 -12.95	SM1701	ABD / 1F / ADZ / 1Y / AEY	96 - 6.99	SM1704	ADL / 2E	10.93 - 4.94	SM1701	ADL / 2E	5.94 - 6.96	SM1704		7.96 - 6.99	SM1704
Model	Year	KYB																																																			
IBIZA	AAU / ABD / ABS / ADZ / 1Y / AAZ	2.93 -12.95	SM1701																																																		
	AAU / ABD / ADZ / 1Y / AAZ	1.96 - 8.99	SM1704																																																		
	ADL / 2E	3.93 - 3.94	SM1701																																																		
	ADL / 2E	4.94 - 8.99	SM1704																																																		
	1F / AEE	3.93 - 4.96	SM1701																																																		
	1F / AEE / AFT	5.96 - 8.99	SM1704																																																		
	AEX / AEY	9.93 - 1.96	SM1704																																																		
	AAV / ABU / 2G	2.93 - 7.94	SM1701																																																		
CORDOBA	ADB / 1F / ABU / ABS / 1Y / AAZ	3.93 -12.95	SM1701																																																		
	ABD / 1F / ADZ / 1Y / AEY	96 - 6.99	SM1704																																																		
	ADL / 2E	10.93 - 4.94	SM1701																																																		
	ADL / 2E	5.94 - 6.96	SM1704																																																		
		7.96 - 6.99	SM1704																																																		

\*Excel-G is a new name of SUPER  
Excel-G ist der neue Name für SUPER  
Excel-G est le nom nouveau pour SUPER



MODEL FAHRZEUG MODELE	YEAR JAHR ANNEE	FRONT/VORNE/AVANT				REAR/HINTEN/ARRIERE			
		PREMIUM Oil	EXCEL-G* Twin-tube Gas	GAS-A-JUST Mono-tube Gas		PREMIUM Oil	EXCEL-G* Twin-tube Gas	GAS-A-JUST Mono-tube Gas	

### Seat (E)

#### Ibiza, Cordoba

1.9 TDI (66kw, 81kw) (6K, 6K/C)	96- 8.99	634950▼ 634810	334950▼ 334810 <u>324025</u>  	+	1,2	443801 <sup>1)</sup>	343274 <sup>1)</sup> <u>353021<sup>1)</sup></u>		1,1
1.8-16V (6K, 6K/C) 2.0 GTi, 2.0 GTi-16V, 2.0SX-16V	93- 8.99	634950▼ 634810	334950▼ 334810 <u>324025</u>  	+	1,2		343283 <sup>1)</sup>		1,1
1.0, 1.4, 1.6, 1.9D Exc. ⊕ Sport sus. (6K, 6K/C)	8.99- 2.02	633950▼ 633712	333950▼ 333712 <u>324025</u>	+	1,2	443296	343297		1,1
1.8, 1.9TD Exc. ⊕ Sport sus. (6K, 6K/C)	8.99- 2.02	634950▼ 634810	334950▼ 334810 <u>324025</u>	+	1,2		343297		1,1
⊕ Sport sus.  (6K, 6K/C)	8.99- 2.02		334950▼ 334810 <u>324025</u>	+	1,2		343297		1,1

#### Cordoba Vario

1.4, 1.6 1.9 SDI (47kw)	97-	633950▼ 633712	333950▼ 333712 <u>324025</u> 	+	1,2	443296 <sup>1)</sup>	343297 <sup>1)</sup>		1,1
1.9 TDI (81kw)	97-	634950▼ 634810	334950▼ 334810 <u>324025</u> 	+	1,2	443296 <sup>1)</sup>	343297 <sup>1)</sup>		1,1

1)

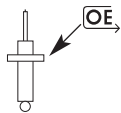

2)

Model		Year	KYB
IBIZA	AAU / ABD / ABS / ADZ / 1Y / AAZ	2.93 -12.95	SM1701
	AAU / ABD / ADZ / 1Y / AAZ	1.96 - 8.99	SM1704
	ADL / 2E	3.93 - 3.94	SM1701
	ADL / 2E	4.94 - 8.99	SM1704
	1F / AEE	3.93 - 4.96	SM1701
	1F / AEE / AFT	5.96 - 8.99	SM1704
	AEX / AEY	9.93 - 1.96	SM1704
	AAV / ABU / 2G	2.93 - 7.94	SM1701
CORDOBA	ADB / 1F / ABU / ABS / 1Y / AAZ	3.93 -12.95	SM1701
	ABD / 1F / ADZ / 1Y / AEY	96 - 6.99	SM1704
	ADL / 2E	10.93 - 4.94	SM1701
	ADL / 2E	5.94 - 6.96	SM1704
		7.96 - 6.99	SM1704

\*Excel-G is a new name of SUPER  
Excel-G ist der neue Name für SUPER  
Excel-G est le nom nouveau pour SUPER

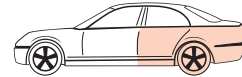
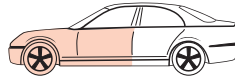

MODEL FAHRZEUG MODELE	YEAR JAHR ANNEE	FRONT/VORNE/AVANT				REAR/HINTEN/ARRIERE			
		PREMIUM Oil	EXCEL-G* Twin-tube Gas	GAS-A-JUST Mono-tube Gas		PREMIUM Oil	EXCEL-G* Twin-tube Gas	GAS-A-JUST Mono-tube Gas	
<b>Seat (E)</b>									
<b>Leon</b>									
(2WD) 1.4, 1.6 Exc. Sport sus.,	10.99-	633208 ▼ 633713	333259 ▼ 333713 <u>324016</u> 		+		343348 <u>915400</u>	553304 <u>243039</u>	
(2WD) 1.8, 1.8T, 1.9SDi, 1.9TDi Exc. Sport sus.,	10.99-	634099 ▼ 634812	334220 ▼ 334812 <u>324016</u> <u>915415</u>		+		343348 <u>915400</u>	553304 <u>243039</u>	
(2WD) + Sport sus.,	10.99-		334220 ▼ 334812 <u>324016</u> <u>915415</u>		+		<u>915400</u>	553304 <u>243039</u>	
(2WD) 	10.99-	634099 ▼ 634812	334220 ▼ 334812 <u>915415</u>		+				
<b>Malaga</b>									
1.2, 1.5, 1.7 D	5.85- 7.86	633812	333812 		+	633814	333814		+
1.2, 1.5, 1.7 D	8.86- 8.89	633813	333813 		+	633815	333815		+
1.2, 1.5, 1.7 D	9.89-	633840	333840 		+	633815	333815		+
<b>Panda, Marbella</b>									
Panda Marbella	79- 87- 3.89	633811 ▼ 633951	333811 ▼ 333951 		+	441038	341212		
Marbella	4.89-					441038	341212		
<b>Ronda</b>									
 Exc. Crono	84- 6.86	633812	333812 		+	633814	333814		+
Crono	84- 6.86				+				+





MODEL FAHRZEUG MODELE	YEAR JAHR ANNEE	FRONT/VORNE/AVANT				REAR/HINTEN/ARRIERE																					
		PREMIUM Oil	EXCEL-G* Twin-tube Gas	GAS-A-JUST Mono-tube Gas		PREMIUM Oil	EXCEL-G* Twin-tube Gas	GAS-A-JUST Mono-tube Gas																			
<b>Seat (E)</b>																											
<b>Strada/Ritmo</b>																											
60, 65, 75, 85 Diesel	78-12.83 79-12.83	633019	333009		+	633044	333047		+																		
					1,1				1,0																		
<b>Toledo</b>																											
1.6, 1.8, 2.0 1.9D, 1.9TD (47kw, 50kw, 55kw) Exc. 1.8i-16V, 2.0i-16V, 1.9TDI	(1L) 91- 99	633950▼ 633712	333950▼ 333712 <u>324025</u>		+	443800 <sup>1)</sup> (SP-001)	343191 <sup>1)</sup> (SP-001) <u>353013</u> <sup>1)</sup> (SP-001)		⊥ ⊕ 1,1																		
			SM1701 <sup>2)</sup> SM1704 <sup>2)</sup>		1,2																						
1.9 TDI (66kw, 81kw)	(1L) 95- 99	634950▼ 634810	334950▼ 334810 <u>324025</u>		+	443800 <sup>1)</sup> (SP-001)	343191 <sup>1)</sup> (SP-001) <u>353013</u> <sup>1)</sup> (SP-001)		⊥ ⊕ 1,1																		
			SM1701 <sup>2)</sup> SM1704 <sup>2)</sup>		1,2																						
1.8i-16V GT 2.0i-16V, 2.0i-16V GT	(1L) 91- 99	634950▼ 634810	334950▼ 334810 <u>324025</u>		+		343191 <sup>1)</sup> (SP-001) <u>353013</u> <sup>1)</sup> (SP-001)		⊥ ⊕ 1,1																		
			SM1701 <sup>3)</sup> SM1704 <sup>3)</sup>		1,2																						
1.6 Exc. Sport sus.,	(1M) 99-	633208▼ 633713	333259▼ 333713 <u>324016</u>		+		343348	553304	⊥ ⊕																		
								<u>243039</u>																			
1.8-20V, 2.3-V5, 1.9 TDI Exc. Sport sus.,	(1M) 99-	634099▼ 634812	334220▼ 334812 <u>324016</u>		+		343348	553304	⊥ ⊕																		
								<u>243039</u>																			
⊕ Sport sus. 1.6, 1.8-20V, 2.3-V5, 1.9 TDI	(1M) 99-		334220▼ 334812 <u>324016</u>		+			553304	⊥ ⊕																		
								<u>243039</u>																			
<p>1)   (SP-001)</p> <p>2) <table border="1"> <thead> <tr> <th>Year</th> <th>KYB</th> </tr> </thead> <tbody> <tr> <td>3.91 - 10.96</td> <td>SM1701</td> </tr> <tr> <td>11.96 - 99</td> <td>SM1704</td> </tr> </tbody> </table></p> <p>3) <table border="1"> <thead> <tr> <th></th> <th>Year</th> <th>KYB</th> </tr> </thead> <tbody> <tr> <td>⊖ ABF</td> <td>3.91 - 10.96</td> <td>SM1701</td> </tr> <tr> <td>ABF</td> <td>11.93 - 10.96</td> <td>SM1704</td> </tr> <tr> <td></td> <td>11.96 - 99</td> <td>SM1704</td> </tr> </tbody> </table></p>										Year	KYB	3.91 - 10.96	SM1701	11.96 - 99	SM1704		Year	KYB	⊖ ABF	3.91 - 10.96	SM1701	ABF	11.93 - 10.96	SM1704		11.96 - 99	SM1704
Year	KYB																										
3.91 - 10.96	SM1701																										
11.96 - 99	SM1704																										
	Year	KYB																									
⊖ ABF	3.91 - 10.96	SM1701																									
ABF	11.93 - 10.96	SM1704																									
	11.96 - 99	SM1704																									

\*Excel-G is a new name of SUPER  
 Excel-G ist der neue Name für SUPER  
 Excel-G est le nom nouveau pour SUPER

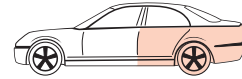
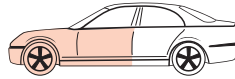

MODEL FAHRZEUG MODELE	YEAR JAHR ANNEE	FRONT/VORNE/AVANT				REAR/HINTEN/ARRIERE			
		PREMIUM Oil	EXCEL-G* Twin-tube Gas	GAS-A-JUST Mono-tube Gas		PREMIUM Oil	EXCEL-G* Twin-tube Gas	GAS-A-JUST Mono-tube Gas	
<b>Seat Commercial (E)</b>									
<b>Inca</b>									
1.0, 1.4, 1.9 D, 1.9 SDI	96-	633950▼ 633712	333950▼ 333712  324025		⊕	443287		553231	⊖
SM1704									
<b>Terra, Trans</b>									
Terra Trans	87- 3.89 85-	633811	333811		⊕	441038	341212		⊖ ⊗ 0,4
SM1804									
Terra	4.89-				0,8	441038	341212		⊖ ⊗ 0,4
<b>Skoda (CS)</b>									
<b>1000,100,110,105,120</b>									
1000, MB 100, L 110, L, LS, R 105, S, L 120, LS, GLS, LSX	64- 69 70- 70- 10.76-	443143	343106	553139	⊖ ⊖ 0,5	443144	343107	553140	⊖ ⊖ 0,5
<b>Fabia</b>									
1.0, 1.4, 1.4-16V, 2.0, 1.9SDi Exc.	(6Y) 1.00-		333872		⊕		343328		⊖ ⊖
1.9TDi Exc.	(6Y) 1.00-		334868		⊕		343328		⊖ ⊖
<b>Favorit</b>									
	88- 94	633835	333835		⊕	441800	341800		⊖ ⊖ 0,8
Exc. ⊕ ABS 917800									
<b>Felicia</b>									
	94- 6.01	633835	333835		⊕	441800	341800		⊖ ⊖
Exc. ⊕ ABS 917802									
<b>Forman</b>									
	90- 95	633835	333835		⊕	441800	341800		⊖ ⊖ 0,8



MODEL FAHRZEUG MODELE	YEAR JAHR ANNEE	FRONT/VORNE/AVANT				REAR/HINTEN/ARRIERE			
		PREMIUM Oil	EXCEL-G* Twin-tube Gas	GAS-A-JUST Mono-tube Gas		PREMIUM Oil	EXCEL-G* Twin-tube Gas	GAS-A-JUST Mono-tube Gas	
<b>Skoda (CS)</b>									
<b>Octavia </b>									
1.6, 1.9D 1.9 TDi-66kw Exc. 1.9 TDi-81kw Exc. Sport sus.,	(1U)	97-	633208 ▼ 633713	333259 ▼ 333713  324016 SM1708	+		343280 ▼ 343348	553206  243037	
1.8-20V, 1.8 Turbo 1.9 TDi-81kw Exc. Sport sus.,	(1U)	97-	634099 ▼ 634812	334220 ▼ 334812  324016 SM1708	+		343280 ▼ 343348	553206  243037	
<b>Octavia </b>									
1.6, 1.9D 1.9 TDi-66kw Exc. 1.9 TDi-81kw Exc. Sport sus.,	(1U)	97-	633208 ▼ 633713	333259 ▼ 333713  SM1708	+		343298	553232	
1.8-20V, 1.8 Turbo 1.9 TDi-81kw Exc. Sport sus.,	(1U)	97-	634099 ▼ 634812	334220 ▼ 334812  SM1708	+		343298	553232	
<b>Pick-Up, Felicia Pick-Up </b>									
	(787)	93- 95	633835	333835  SM1708	+	441800	341800		
1.3, 1.6, 1.9D	(797)	96-	633835	333835 Exc. + ABS	+	443291	343285		
<b>Subaru (J)</b>									
<b>E Series, Libero</b>									
E10 1.0 , E12 1.2	(KJ5, KJ6) (KJ8)	84- 93					343294		
E12 1.2 E12 1.2	(FA7) (FA8)	5.93-				442037			

\*Excel-G is a new name of SUPER  
Excel-G ist der neue Name für SUPER  
Excel-G est le nom nouveau pour SUPER

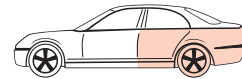
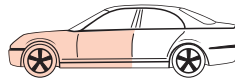

MODEL FAHRZEUG MODELE	YEAR JAHR ANNEE	FRONT/VORNE/AVANT				REAR/HINTEN/ARRIERE			
		PREMIUM Oil	EXCEL-G* Twin-tube Gas	GAS-A-JUST Mono-tube Gas		PREMIUM Oil	EXCEL-G* Twin-tube Gas	GAS-A-JUST Mono-tube Gas	
<b>Subaru (J)</b>									
<b>Forester</b>									
2.0 (4WD) Exc. 2.0 Turbo (4WD)	(SF5)	97-		334190 L 334189 R		+		334192 L <sup>1)</sup> 334191 R <sup>1)</sup> Exc.	+
2.0 Turbo (4WD)	(SF5)	97-		334190 L 334189 R		+		OE =	
<b>Impreza  (GC/GD),  (GF/GG)</b>									
(2WD) (GC/GF 3/5/7) 1.6, 1.8, 2.0		92- 7.98		334114L <sup>2)</sup> ▼ 334113R <sup>2)</sup> ▼ 334254 L 334253 R		+		334147 L 334146 R	+
(2WD) (GC/GF 3/5/7) 1.6, 1.8, 2.0		8.98-12.00		334254 L <sup>3)</sup> 334253 R <sup>3)</sup>		+		334147 L 334146 R	+
(4WD) (GC/GF 4/6/8) 1.6, 1.8, 2.0 Exc. GT (2.0 Turbo)		92- 7.98		334114L <sup>2)</sup> ▼ 334113R <sup>2)</sup> ▼ 334254 L 334253 R		+		334110 L 334109 R	+
(4WD) (GC/GF 4/6/8) 1.6, 1.8, 2.0 Exc. GT (2.0 Turbo)		8.98-12.00		334254 L <sup>3)</sup> 334253 R <sup>3)</sup>		+		334110 L 334109 R	+
(4WD) (GC/GF8*L8) 2.0 Turbo		92- 7.98		334163L <sup>2)</sup> ▼ 334162R <sup>2)</sup> ▼ 334256 L 334255 R		+		334110 L 334109 R	+
(4WD) (GC/GF8*L8) 2.0 Turbo		8.98-12.00		334256 L <sup>3)</sup> 334255 R <sup>3)</sup>		+		334110 L 334109 R	+
(4WD) 2.0, 2.0 Turbo WRX Exc. WRX-STi	(GD)	10.00-		334305 L 334304 R  <u>324027 L</u> <u>324026 R</u>		+		334307 L 334306 R  <u>324029 L</u> <u>324028 R</u>	+
(4WD) 1.6, 2.0, 2.0 Turbo WRX	(GG)	10.00-		334301 L 334300 R		+		334303 L 334302 R	+

1)	(A)	(B)
334191/334192	402mm	Shape N
OE = Self Leveling	408mm	Shape F

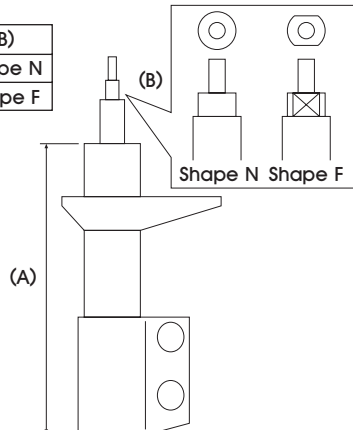

2) OE = 20360 FA\*\*\*

3) OE = 20361 FA\*\*\*



MODEL FAHRZEUG MODELE	YEAR JAHR ANNEE	FRONT/VORNE/AVANT				REAR/HINTEN/ARRIERE			
		PREMIUM Oil	EXCEL-G* Twin-tube Gas	GAS-A-JUST Mono-tube Gas		PREMIUM Oil	EXCEL-G* Twin-tube Gas	GAS-A-JUST Mono-tube Gas	
<b>Subaru (J)</b>									
<b>Justy, J Series</b>									
(KA, KD) JF1K **A → JF1K **J	2.84- 7.88					632037 L 632036 R			
(KA, KD) JF1K **K → JF1K **S	7.88- 95	633207 L 633206 R				632077 L 632076 R			
(HSJ56, HSN56) (  =TSMM ***) Exc.  ABS	96-	633134 L 633133 R	333195 L 333194 R			633174	333196		
<b>Legacy  (BC, BD, BE),  (BF, BJ, BG, BH) Exc. </b>									
(BC/BF/BJ) 1.6, 1.8, 2.0, 2.2	89- 6.91		334106 L 334105 R				334145 L 334144 R O.E.=20361AA***		
(BC/BF/BJ) 1.6, 1.8, 2.0, 2.2	7.91-12.93		334106 L 334105 R				334147 L 334146 R O.E.=20362AA***		
(BD/BG) 2.0, 2.2	1.94- 99		334114 L▼ 334113 R▼  334254 L 334253 R				334165 L 334164 R		
(BC/BF/BJ) 1.8, 2.2 Exc.  CH	89- 6.91		334106 L 334105 R				334108 L 334107 R O.E.=20361AA***		
(BC/BF/BJ) 1.8, 2.2	1.90- 6.91		334106 L 334105 R				O.E.=20361AA28*/29*, 48*/49*		
(BC/BF/BJ) 1.8, 2.0, 2.2 Exc. 2.0 Turbo (BC/BF5*L8)	7.91-12.93		334106 L 334105 R				334110 L 334109 R O.E.=20362AA***		
 2.0 Turbo (BC/BF5*L8)	7.91-12.93		334112 L 334111 R				334110 L 334109 R		
(BD/BG 5,7) 2.0, 2.2	1.94- 5.96		334114 L▼ 334113 R▼  334254 L 334253 R				334116 L 334115 R O.E.=20362AC***		
(BD/BG 5,7) 2.0, 2.2	6.96- 99		334114 L▼ 334113 R▼  334254 L 334253 R				334116 L <sup>1)</sup> 334115 R <sup>1)</sup>  335019 L <sup>2)</sup> 335018 R <sup>2)</sup>		
(BD/BG9*L9) 2.5 Exc. Outback (BG9*LB)	6.96- 99		334112 L 334111 R				335019 L 335018 R		
1) OE = 20363 AC *** 2) OE = 20364 AC ***									

\*Excel-G is a new name of SUPER  
Excel-G ist der neue Name für SUPER  
Excel-G est le nom nouveau pour SUPER

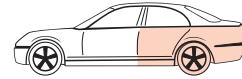
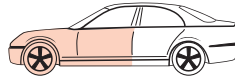

MODEL FAHRZEUG MODELE	YEAR JAHR ANNEE	FRONT/VORNE/AVANT				REAR/HINTEN/ARRIERE			
		PREMIUM Oil	EXCEL-G* Twin-tube Gas	GAS-A-JUST Mono-tube Gas		PREMIUM Oil	EXCEL-G* Twin-tube Gas	GAS-A-JUST Mono-tube Gas	
<b>Subaru (J)</b>									
<b>Legacy  (BC, BD, BE),  (BF, BJ, BG, BH) Exc. </b>									
(BG9*LB) 2.5 Outback	6.96- 99		334167 L 334166 R				335021 L 335020 R		
 2.0, 2.5 (BE/BH) Exc. , , Outback	12.98-		334274 L 334273 R				341275		
 2.5 Outback (BE/BH) Exc. ,	12.98-		334276 L 334275 R				341276		
<b>L Series </b>									
(AU2) 	5.79- 84		333227 OE= 721032 240/241				343284		 0,4
(AU2) 	84-		333160 OE= 721032 081				343284		 0,4
(AU5) 	5.79-		333227				343284		 0,4
<b>L Series  Exc. </b>									
(AM1, AM2) 1300, 1600	5.79- 84		333226				344276		 0,4
(AM4) 1800	5.79- 84		333160				344276		 0,4
(AM3, AM5, AJ 5) 1600, 1800	5.79- 84		333227				344276		 0,4
(AN1) 1300 DL	8.84- 91		333231 L 333230 R				341214		 1,3
(AN2, AN4) 1600 DL, 1800 DL, GL	8.84- 93		333159 L 333158 R				341214		 1,3
(AN3) 1600 DL	8.84- 7.85		333159 L 333158 R				341215		 1,3
(AN5, AK5) 1800 DL, GL	8.84- 7.85		333235 L 333234 R				341215		 1,3
(AN3, AN5, AK5) 1600 DL, 1800 DL, GL	8.85- 7.86		333235 L 333234 R				341215		 1,3

\*Excel-G is a new name of SUPER  
Excel-G ist der neue Name für SUPER  
Excel-G est le nom nouveau pour SUPER



MODEL FAHRZEUG MODELE	YEAR JAHR ANNEE	FRONT/VORNE/AVANT				REAR/HINTEN/ARRIERE			
		PREMIUM Oil	EXCEL-G* Twin-tube Gas	GAS-A-JUST Mono-tube Gas		PREMIUM Oil	EXCEL-G* Twin-tube Gas	GAS-A-JUST Mono-tube Gas	
<b>Subaru (J)</b>									
<b>L Series  Exc. </b>									
(AN3, AN5, AK5) 1600 DL, 1800 DL, GL	8.86- 93		333235 L 333234 R				341216		
<b>L Series, Leone  (AF),  (AB),  (AW) (5.79-85) Exc. </b>									
(AF 1/2, AB 1/2/4, AW 4) 	5.79- 85		333226				343056		
(AF5, AB5) 	5.79- 85		333227				344276		
<b>L Series, Leone  (AG),  (AC),  XT (AX) (8.84-93) Exc. </b>									
(AG1, AG2, AG4) 1300, 1600, 1800 DL, GL, GT	8.85- 90		333231 L 333230 R				341215		
(AC1, AC2, AC4) 1300, 1600, 1800 DL, GL, GT 	8.84- 93		333231 L 333230 R				341214		
(AC1, AC2, AC4) 1300, 1600, 1800 DL, GL, GT 	8.84- 93		333159 L 333158 R				341214		
(AX4) XT 1800 Turbo	8.84- 91		333229 L 333228 R				341214		
 1800 GL (AG5*L3), 4WD Turbo (AG5*L9) Exc. RX (AG5*L8)	8.85- 7.86		333235 L 333234 R				341215		
 1800 GL (AG5*L3), 4WD Turbo (AG5*L9) Exc. RX (AG5*L8)	8.86- 90		333235 L 333234 R				341216		
(AC5*L2/L3) 1800 DL, GL	8.84- 89		333235 L 333234 R				341215		
 RX 1800 Turbo (AC/AG5*L8) Exc. 4WD Turbo (AG7, AC7)	8.84- 7.86		333233 L 333232 R				341215		
 RX 1800 Turbo (AC/AG5*L8) Exc. 4WD Turbo (AG7, AC7)	8.86- 89		333233 L 333232 R				341216		
<b>Rex 600</b>									
 (K 21, 22, 23, 24 series)	6.72- 81			552014				552015	
 (KF 1)	81-						342011		

\*Excel-G is a new name of SUPER  
Excel-G ist der neue Name für SUPER  
Excel-G est le nom nouveau pour SUPER



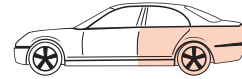
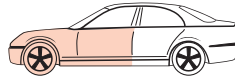

MODEL FAHRZEUG MODELE	YEAR JAHR ANNEE	FRONT/VORNE/AVANT				REAR/HINTEN/ARRIERE			
		PREMIUM Oil	EXCEL-G* Twin-tube Gas	GAS-A-JUST Mono-tube Gas		PREMIUM Oil	EXCEL-G* Twin-tube Gas	GAS-A-JUST Mono-tube Gas	
<b>Subaru (J)</b>									
<b>Vivio</b>									
 	8.93- 7.94		332083 L 332082 R		+		332085 L 332084 R		+
 	8.94-		332083 L 332082 R		+		332087 L 332086 R		+
<b>Suzuki (J)</b>									
<b>Alto</b>									
Alto (SS 30 V, SS 40 V)	10.81-				+	442021		552020	⊖ ○ 0,6
Alto 600 (SS 40 F)		632027 L 632026 R			+	442021		552020	⊖ ○
Alto 800 (SS 80 F, SS80 G)	81- 1.86	632006	332016		+	442021		552020	⊖ ○ 0,6
SB 308 (CA 91, CB 91) 00100001 → 00200000	7.86-12.87	632051 L 632050 R			+	442030			⊖ ⊖
SB 308 (CA 91, CB 91) 00200001 →	88- 92	632051 L 632050 R			+		342020		⊖ ⊖
SH 410 (FA 11, FB 11)	94-	632094 L 632093 R			+		342018		⊖ ⊖
<b>Baleno Exc. </b>									
Incl. ⊕ ABS 1.3 1.6  ,	95-	633184 L▼ 633183 R▼  633222 L 633221 R	333214 L▼ 333213 R▼  333313 L 333312 R		+	633186 L 633185 R	333216 L 333215 R		+
Incl. ⊕ ABS 1.3 1.5 1.6  ,	95-	633184 L▼ 633183 R▼  633222 L 633221 R	333214 L▼ 333213 R▼  333313 L 333312 R		+		333216 L 333215 R		+
,  Incl. ⊕ ABS 1.8	95-		333214 L▼ 333213 R▼  333313 L 333312 R		+		333216 L 333215 R		+
Incl. ⊕ ABS 1.6  , 1.8	95-		333214 L▼ 333213 R▼  333313 L 333312 R		+		333216 L 333215 R		+



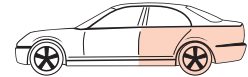
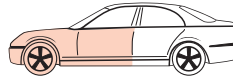

MODEL FAHRZEUG MODELE	YEAR JAHR ANNEE	FRONT/VORNE/AVANT				REAR/HINTEN/ARRIERE			
		PREMIUM Oil	EXCEL-G* Twin-tube Gas	GAS-A-JUST Mono-tube Gas		PREMIUM Oil	EXCEL-G* Twin-tube Gas	GAS-A-JUST Mono-tube Gas	
<b>Suzuki (J)</b>									
<b>Ignis</b>									
1.3 Incl.	(FH) 10.00- 3.03		333347 L 333346 R				342026		
1.3 Incl.	(FH) 10.00- 3.03		333347 L 333346 R				342027		
<b>Jimny</b>									
1.3 ,  (SN413: JA33, JB33) JSAFJA33***, JSAFJB33***	98-		343287				343288		
<b>Jimny/Samurai (SJ)</b>									
Jimny (LJ 10, 20, LJ 81)	70- 77	443156	343185	553107		443194	343153	553106	
Jimny (SJ 10, SJ 20, LJ 80 series)	77-	443156	343185	553107		443067	343194	553024	
Jimny/Samurai (SJ 30, SJ 410, SJ 413)	5.81- 88	443156	343185	553107		443194	343153	553106	
<b>Liana</b>									
	(ER) 7.01-		333355 L 333354 R				333357 L 333356 R		
<b>SJ413/SJ419 Samurai, Santana SJ413</b>									
1.3 SJ413 Samurai, Santana	88-	443156	343185	553107		443194	343153	553106	
1.9 TD SJ419 Samurai, Santana	98-			553220				553221	
<b>Swift</b>									
1000 (AA41): SA 310 1300 (AA51): SA 413	10.83-10.86	632031 L 632030 R	332023 L 332022 R			442028	342012	552021	
1000 (AA43): SA 310 1300 (AA53): SA 413 Gti/GXi (AA33): SA 413	10.86- 89	632049 L 632048 R				441059	341075		
<b>Swift (  :  = TSMM... )</b>									
 1.0 (AA 44/AB 44, AH 44: SF 310) 1.3 (AA 35/AB 35, AH 35: SF 413)	92- 92-	633134 L 633133 R	333195 L 333194 R			633174	333196		
					1,3				0,6

\*Excel-G is a new name of SUPER  
Excel-G ist der neue Name für SUPER  
Excel-G est le nom nouveau pour SUPER

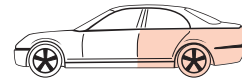
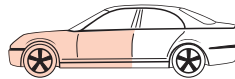

MODEL FAHRZEUG MODELE	YEAR JAHR ANNEE	FRONT/VORNE/AVANT			⚙️ ⌚	REAR/HINTEN/ARRIERE			⚙️ ⌚
		PREMIUM Oil	EXCEL-G* Twin-tube Gas	GAS-A-JUST Mono-tube Gas		PREMIUM Oil	EXCEL-G* Twin-tube Gas	GAS-A-JUST Mono-tube Gas	
<b>Suzuki (J)</b>									
<b>Swift (  :  = JSAE... )</b>									
 1.0 (AA 44/AB 44: SF 310) 1.3 (AA 35/AB 35: SF 413) Exc. GTi 00100001→00140000	1.89- 92 1.89- 92	632069 L 632068 R	332053 L 332052 R		⊕ 1,3	632067	332051		⊕ 0,6
 1.3 GTi (AA 34: SF 413) 00100001→00104275	1.89-12.89	632069 L 632068 R	332053 L 332052 R		⊕ 1,3	633174	333196		⊕ 0,6
 1.3 GTi (AA 34: SF 413) 00104276→00140000	1.90- 92	632062 L 632061 R	332050 L 332049 R		⊕ 1,3	633174	333196		⊕ 0,6
 1.0 (AA 44/AB 44: SF 310) 1.3(AA 35/AB 35, AA 34: SF 413) Incl. GTi 00140001→	92- 92-	633134 L 633133 R	333195 L 333194 R		⊕ 1,3	633174	333196		⊕ 0,6
 1.3 (AF 35: SF 413) 00100001→00102077	1.89- 90	632062 L 632061 R	332050 L 332049 R		⊕ 1,3	632067	332051		⊕ 0,6
 1.3 (AF 35: SF 413) 00102078→	1.91-	633134 L 633133 R	333195 L 333194 R		⊕ 1,3	633174	333196		⊕ 0,6
 1.3  (AH 35 : SF 413)  →00107571 1.6  (AH 14 : SF 416)  →00109591 1.6  (AJ 14 : SF 416)  →00102383	1.89- 90 1.89- 90 1.89- 90	632062 L 632061 R	332050 L 332049 R		⊕ 1,3	633174	333196		⊕ 0,6
 1.3  (AH 35 : SF 413)  00107572→ 1.6  (AH 14 : SF 416)  00109592→ 1.6  (AJ 14 : SF 416)  00102384→	90- 90- 90-	633134 L 633133 R	333195 L 333194 R		⊕ 1,3	633174	333196		⊕ 0,6
 1.3 (AK 35 : SF 413)	92-	633134 L 633133 R	333195 L 333194 R		⊕ 1,3	633174	333196		⊕ 0,6
<b>Vitara (  JSAE TA/TD... , 2S3TA... )</b>									
1.6  (TA0: SE 416) 1.6  (TD0: SE 416) →TA/TD 0##01110000	89- 95 91- 95	634020 L 634019 R	334016 L 334015 R		⊕ 1,2		343247	553158	⊥ ⊕ 0,6
1.6  Incl. ⊕ ABS (TA0: SE416) 1.6  Incl. ⊕ ABS (TD0: SE416) TA/TD 0##01110001→	96- 96-	634073 L 634072 R	334140 L 334139 R		⊕ 1,2		343247	553158	⊥ ⊕ 0,6
2.0-V6  Incl. ⊕ ABS (TD1: SV620) 2.0 TD  Incl. ⊕ ABS (TD3: SV420 D)	96- 96-	634073 L 634072 R	334140 L 334139 R		⊕ 1,2		343247	553158	⊥ ⊕ 0,6

\*Excel-G is a new name of SUPER  
Excel-G ist der neue Name für SUPER  
Excel-G est le nom nouveau pour SUPER



MODEL FAHRZEUG MODELE	YEAR JAHR ANNEE	FRONT/VORNE/AVANT			⚙️ ⌚	REAR/HINTEN/ARRIERE			⚙️ ⌚
		PREMIUM Oil	EXCEL-G* Twin-tube Gas	GAS-A-JUST Mono-tube Gas		PREMIUM Oil	EXCEL-G* Twin-tube Gas	GAS-A-JUST Mono-tube Gas	
<b>Suzuki (J)</b>									
<b>Santana SE416 Vitara (  :  VSEOSJ..., VSEE TV/TW...)</b>									
1.6  ,  Incl. ⊕ ABS (JJ/JV61,TV0) 1.6  Incl. ⊕ ABS (TWO)	89- 89-	634073 L 634072 R	334140 L 334139 R		⊕ 1,2		343247	553158	⊥ ⊖ 0,6
<b>Grand Vitara (  JSAF TA/TD/TL..., 2S2GTA...)</b>									
1.6  (TA0: SQ416) 2.0  ,  (TA5, TL5: SQ420) 2.0 TD  (TD3: SQ420) 2.5  (TD6: SQ425) Incl. ⊕ ABS	98-	634090 L 634089 R	334196 L 334195 R		⊕		343247	553158	⊥ ⊖
<b>Wagon R+</b>									
,  Incl. ⊕ ABS 1.0 (SR410 : MA61) 1.2 (SR412 : MA81,MB81)	97- 98-		332093 L 332092 R		⊕		342020		⊖ ⊖
Incl. ⊕ ABS 1.3 (RB413 : MA53)	00-		333307 L 333306 R		⊕		343331		⊖ ⊖
<b>X-90</b>									
1.6  Incl. ⊕ ABS (LA 1) 1.6  Incl. ⊕ ABS (LB 1)	96- 96-	634073 L 634072 R	334140 L 334139 R		⊕ 1,2		343247	553158	⊥ ⊖ 0,6
<b>Suzuki Commercial (J)</b>									
<b>Carry</b>									
Super Carry (SK 410 K/T) ,	86-	633061 L 633060 R			⊕				
Super Carry (SK 410 V) 	86-	633061 L 633060 R			⊕	442028	342012		⊖ ⊖ 0,8
<b>Talbot (F) (GB)</b>									
<b>Alpine</b>									
	7.75- 80	443114	343051	553072	⊥ ⊖	443115	343052	553131	⊥ ⊖

\*Excel-G is a new name of SUPER  
Excel-G ist der neue Name für SUPER  
Excel-G est le nom nouveau pour SUPER

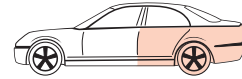
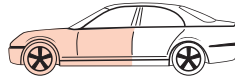

MODEL FAHRZEUG MODELE	YEAR JAHR ANNEE	FRONT/VORNE/AVANT				REAR/HINTEN/ARRIERE			
		PREMIUM Oil	EXCEL-G* Twin-tube Gas	GAS-A-JUST Mono-tube Gas		PREMIUM Oil	EXCEL-G* Twin-tube Gas	GAS-A-JUST Mono-tube Gas	
<b>Talbot (F) (GB)</b>									
<b>Avenger</b>									
1300, 1600 (800 series)	9.74-10.77		363005				341009 <sup>1)</sup> 343170 <sup>2)</sup>		
1300, 1600	10.77- 5.81		363005				341006 <sup>1)</sup> 343170 <sup>2)</sup>		
<b>Horizon</b>									
	77- 86	443131	343025	553130		443130	343026		
<b>Minx, Scepter, Rapier, Vogue, Hunter</b>									
Minx, Scepter (Exc. Estate) Rapier, Alpine Fastback H 120, Vogue Humber, Scepter Mk III Hunter Saloon	67- 76 67- 76 67- 80	665027				443113			
<b>Samba</b>									
	82-	633021	333020			441041	341039		
<b>Simca</b>									
Simca 1307/1308/1309	75- 80	443114	343051	553072		443115	343052	553131	
<b>Solara</b>									
	80-	443131	343025	553130		443130	343026		
<b>Sunbeam</b>									
1000, 1300, 1600	10.77- 80		363005				341006 <sup>1)</sup> 343170 <sup>2)</sup>		
1)  2)									
<b>Tagora</b>									
	80- 85	664008	364002			444036	344004	554032	

Talbot



MODEL FAHRZEUG MODELE	YEAR JAHR ANNEE	FRONT/VORNE/AVANT				REAR/HINTEN/ARRIERE			
		PREMIUM Oil	EXCEL-G* Twin-tube Gas	GAS-A-JUST Mono-tube Gas		PREMIUM Oil	EXCEL-G* Twin-tube Gas	GAS-A-JUST Mono-tube Gas	
<b>Toyota (J)</b>									
<b>4-Runner</b>									
 LN 130, VZN 130	8.89-		344202	554069			344254	554071	
					⊥ ⊕ 0,8				⊥ ⊖ 0,4
<b>Avensis </b>									
1.6, 1.8, 2.0 (AT220, AT221, ST220) 2.0 Diesel Turbo (CT220)	10.97- 7.99		334204 L 334203 R		⊕		334206 L 334205 R		⊕
1.6, 1.8, 2.0 (AT220, AT221, ST220) 2.0 Diesel Turbo (CT220)	7.99- 7.00		334204 L 334203 R		⊕		334330 L 334329 R		⊕
VVTi 1.6, 1.8, 2.0 (ZZT220, ZZT221, AZT220)	7.00-12.02		334204 L 334203 R		⊕		334330 L 334329 R		⊕
2.0 D-4D (CDT220)	7.00-12.02		334204 L 334203 R		⊕		334330 L 334329 R		⊕
1.8, 2.0, 2.4 2.0 D-4D	12.02-		334816 L 334815 R		⊕		341815		⊥ ⊕
<b>Avensis Verso </b>									
2.0, 2.0D	8.01-		334320 L 334319 R		⊕		344362		⊥ ⊕
<b>Blizzard</b>									
LD 10, LD 10 V	3.80- 5.84	443152		553144	○ ○	443150		553143	○ ○
<b>Camry</b>									
(SV10, CV10, SV11) 1800, 2000, 2000 Diesel	3.82- 7.86	665046	365037		□ 2,8		333012 L 333011 R		⊕ 1,8
(SV20, SV21, CV20, VZV21) 1800, 2000 i, 2000 TD, 2500-V6	10.86- 91		365061		□ 2,4		365062		□ 2,3
(SV25) 2000 i	8.88- 91		365061		□ 2,4		334055 L 334054 R		⊕ 2,3
(SV20, SV21, CV20, VZV21) 1800, 2000 i, 2000 TD, 2500-V6	10.86- 92		365061		□ 2,4		365063		□ 2,3

\*Excel-G is a new name of SUPER  
 Excel-G ist der neue Name für SUPER  
 Excel-G est le nom nouveau pour SUPER

= **ULTRASR**

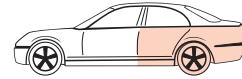
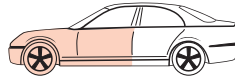

MODEL FAHRZEUG MODELE	YEAR JAHR ANNEE	FRONT/VORNE/AVANT				REAR/HINTEN/ARRIERE			
		PREMIUM Oil	EXCEL-G* Twin-tube Gas	GAS-A-JUST Mono-tube Gas		PREMIUM Oil	EXCEL-G* Twin-tube Gas	GAS-A-JUST Mono-tube Gas	
<b>Toyota (J)</b>									
<b>Camry</b>									
(SXV10, VCV10) 2200, 3000	6.91- 8.94		365085 <sup>1)</sup> 334132 L 334131 R				365097 <sup>1)</sup> 334134 L 334133 R		
(SXV10, VCV10) 2200, 3000	8.94- 8.96		365096 <sup>1)</sup> 334171 L 334170 R				365097 <sup>1)</sup> 334134 L 334133 R		
(SXV10, VCV10) 2200, 3000	3.92- 8.94		334132 L 334131 R				334134 L 334133 R		
(SXV10, VCV10) 2200, 3000	8.94- 7.96		334171 L 334170 R				334134 L 334133 R		
(SXV20, MCV20) 2200, 3000	8.96-		334246 L 334245 R				334134 L 334133 R		
1)									
<b>Carina</b>									
(TA/RA 10/30 series) 1400, 1600, 1800, 2000	2.70- 9.77	665021	365001			443099	343036	553027	
(TA 16 V/19 V/49 V) 1400, 1600	1.76- 8.81	665021	365001			443098			
(TA 41/45/46/47, RA 45/46) 1500, 1800 (AA 60, SA 60, CA 60, TA 60/62)	10.77- 7.81 8.81- 8.85	665021	365001			443102	343039	553041	
(TA 61/63, RA 63) 1600, 1800, 2000	8.81- 8.85	665024	365005				343042	553063	
(TA 67 V, CA 67 V) 1600, 1800 Diesel	9.81- 9.83	665021	365001			443103			
(SA 60 G) 1800	2.82- 8.85	665021	365001			443102	343039	553041	
<b>Carina II (Corona)</b>									
(ST 150, CT 150) 1800	2.83- 4.85	665047	365041				333003 L 333002 R		

Toyota



MODEL FAHRZEUG MODELE	YEAR JAHR ANNEE	FRONT/VORNE/AVANT				REAR/HINTEN/ARRIERE			
		PREMIUM Oil	EXCEL-G* Twin-tube Gas	GAS-A-JUST Mono-tube Gas		PREMIUM Oil	EXCEL-G* Twin-tube Gas	GAS-A-JUST Mono-tube Gas	
<b>Toyota (J)</b>									
<b>Carina II (Corona)</b>									
(AT 151) 1600	5.85-11.87		363059				333003 L 333002 R		
					3,2				2,1
(ST 150, CT 150) 1800, 2000 Diesel	5.85-11.87		365058				333003 L 333002 R		
					3,2				2,1
1600, 1600 i (AT 171) 	12.87- 3.92		363062				333064 L 333063 R		
					2,6				2,2
2000 i (ST 171) 	12.87- 3.92		365068				334028 L 334027 R		
					2,6				2,2
2000 Diesel (CT 170) 	12.87- 3.92		365068				333064 L 333063 R		
					2,6				2,2
<b>Carina E</b> (  :  = JT... )									
1.6 (AT 190) Incl.  ABS Exc. Rough road package	2.92- 1.96		333198 L 333197 R				333108 L 333107 R		
					2,6				4,4
Rough road package 1.6 (AT 190) Incl.  ABS	2.92- 1.96		333198 L 333197 R				333113 L 333112 R		
					2,6		O.E.=48530-20800/-20810/-2B270/-29385 O.E.=48540-20800/-20810/-2B270/-29085		4,4
2.0 D, 2.0 TD (CT 190) Incl.  ABS Exc. Rough road package	2.92- 1.96		365081				333108 L 333107 R		
					2,6				4,4
Rough road package 2.0 D, 2.0 TD (CT 190) Incl.  ABS	2.92- 1.96		365081				333113 L 333112 R		
					2,6		O.E.=48530-20800/-20810/-2B270/-29385 O.E.=48540-20800/-20810/-2B270/-29085		4,4
2.0i (ST 191) Incl.  ABS, Exc. GTi Exc. Rough road package	2.92- 1.96		365081				334064 L 334063 R		
					2,6				4,4
Rough road package 2.0i (ST 191) Incl.  ABS Exc.GTi	2.92- 1.96		365081				334062 L 334061 R		
					2,6		O.E.= 48530-20820/-20850/-2B260 O.E.= 48540-20820/-20850/-2B260		4,4
2.0 GTi (ST 191) Incl.  ABS	2.92- 1.96						334064 L 334063 R		
					2,6				4,4
<b>Carina E</b> (  :  = JT... )									
1.6 i (AT 190) Incl.  ABS 1.8 i (AT 191) Incl.  ABS	11.92- 1.96 2.94- 1.96		333198 L 333197 R				333113 L 333112 R		
					2,6				

\*Excel-G is a new name of SUPER  
Excel-G ist der neue Name für SUPER  
Excel-G est le nom nouveau pour SUPER



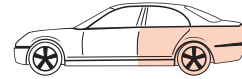
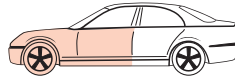

MODEL FAHRZEUG MODELE	YEAR JAHR ANNEE	FRONT/VORNE/AVANT				REAR/HINTEN/ARRIERE			
		PREMIUM Oil	EXCEL-G* Twin-tube Gas	GAS-A-JUST Mono-tube Gas		PREMIUM Oil	EXCEL-G* Twin-tube Gas	GAS-A-JUST Mono-tube Gas	
<b>Toyota (J)</b>									
<b>Carina E</b> (  :  = JT... )									
2.0D (CT 190) Incl. ⊕ ABS 2.0TD (CT 190) Incl. ⊕ ABS	11.92- 1.96 11.92- 1.96		365081		 2,6		333113 L 333112 R		
2.0i (ST 191) Incl. ⊕ ABS	11.92- 1.96		365081		 2,6		334062 L 334061 R		
<b>Carina E</b> ,  (  :  = SB... )									
1.6i (AT 190) Incl. ⊕ ABS Exc.	12.92- 8.93		333198 L 333197 R		 2,6		333108 L 333107 R		 4,4
 1.6i (AT 190) Incl. ⊕ ABS	12.92- 8.93		333198 L 333197 R		 2,6		333113 L 333112 R O.E.=48530-20800/-20810 O.E.=48540-20800/-20810		 4,4
1.6i (AT 190) Incl. ⊕ ABS 1.8i (AT 191) Incl. ⊕ ABS Exc.	8.93- 1.96		334138 L 334137 R		 2,6		334064 L 334063 R		 4,4
 1.6i (AT 190) Incl. ⊕ ABS 1.8i (AT 191) Incl. ⊕ ABS	8.93- 1.96		334138 L 334137 R		 2,6		334062 L 334061 R O.E.=48530-20820/-20850/-05030 O.E.=48540-20820/-20850/-05030		 4,4
1.6i (AT 190) Incl. ⊕ ABS 1.8i (AT 191) Incl. ⊕ ABS	1.96- 98 1.96- 98		334138 L 334137 R		 2,6		334062 L 334061 R		 4,4
2.0i (ST 191) Incl. ⊕ ABS 2.0 D, 2.0 TD (CT 190) Incl. ⊕ ABS Exc. , GTi	12.92-12.94 8.93-12.94		365081 O.E.=48510/20-20890 334138 L 334137 R O.E.=48510/20-05010		  2,6		334064 L 334063 R		 4,4
 2.0i (ST 191) Incl. ⊕ ABS 2.0 D, 2.0 TD (CT 190) Incl. ⊕ ABS Exc. GTi	12.92-12.94 8.93-12.94		365081 O.E.=48510/20-20890 334138 L 334137 R O.E.=48510/20-05010		  2,6		334062 L 334061 R O.E.=48530-20820/-20850/-05030 O.E.=48540-20820/-20850/-05030		 4,4
2.0i (ST 191) Incl. ⊕ ABS 2.0 D, 2.0 TD (CT 190) Incl. ⊕ ABS Exc. , GTi	12.94- 1.96 12.94- 1.96		334138 L 334137 R		 2,6		334064 L 334063 R		 4,4
 2.0i (ST 191) Incl. ⊕ ABS 2.0 D, 2.0 TD (CT 190) Incl. ⊕ ABS Exc. GTi	12.94- 1.96 12.94- 1.96		334138 L 334137 R		 2,6		334062 L 334061 R O.E.=48530-20820/-20850/-05030 O.E.=48540-20820/-20850/-05030		 4,4
2.0i (ST 191) Incl. ⊕ ABS, Exc. GTi 2.0 D, 2.0 TD (CT 190) Incl. ⊕ ABS	1.96- 98 1.96- 98		334138 L 334137 R		 2,6		334062 L 334061 R		 4,4

\*Excel-G is a new name of SUPER  
Excel-G ist der neue Name für SUPER  
Excel-G est le nom nouveau pour SUPER





MODEL FAHRZEUG MODELE	YEAR JAHR ANNEE	FRONT/VORNE/AVANT				REAR/HINTEN/ARRIERE			
		PREMIUM Oil	EXCEL-G* Twin-tube Gas	GAS-A-JUST Mono-tube Gas		PREMIUM Oil	EXCEL-G* Twin-tube Gas	GAS-A-JUST Mono-tube Gas	
<b>Toyota (J)</b>									
<b>Carina E</b> (  :  = SB... )									
1.6i (AT 190) Incl. ⊕ ABS 1.8i (AT 191) Incl. ⊕ ABS 2.0D, 2.0TD (CT 190) Incl. ⊕ ABS 2.0i (ST 191) Incl. ⊕ ABS	5.95- 98		334138 L 334137 R		⊕ 2,6		334062 L 334061 R		⊕
<b>Celica</b> ,  ,  ,									
1600, 2000 (TA 20, RA 20 series)	12.70- 9.75	665023	365022		□ 2,4	443099	343036	553027	⊥ ○
1600, 2000 (TA 23/28/35, RA 23/28/35)	10.75- 8.77	665021	365001		□ 2,4	443099	343036	553027	⊥ ○
1600, 1800, 2000 ⊕ ⊗ (TA 45/46/47, RA 45)	10.77- 7.80	665021	365001		□ 2,4		343039	553041	⊥ ○ 0,6
1600, 2000, 2600 ⊕ ⊗ (TA 40, RA 40, MA 45/46)	10.77- 7.80	665024	365005		□ 2,4		343039	553041	⊥ ○ 0,6
1600, 1800, 2000, 2800 (TA 55/61/63, RA 55/63, MA 55/56)	8.80- 7.81	665024	365005		□ 2,4		343042	553063	⊥ ○ 0,6
1.6 (TA60) 0-0	8.81- 7.85	665021	365001		□ 2,4	443102	343039	553041	⊥ ○ 0,6
2.0 ST, XT (RA 60) 0-0	8.81- 7.85	665024	365005		□ 2,4	443102	343039	553041	⊥ ○ 0,6
1.6 GT, GTS (AA63) 2.0 XT, ST, GT (RA61/63/65, SA63) 0-4	8.83- 7.85 8.81- 1.85	665024	365005		□ 3,2		343042	553063	⊥ ○ 0,7
2800 Supra (MA 61)	12.81- 8.83	665037	365026 ▼ 365076		□ 2,4		343042	553063	⊥ ○ 0,7
2800 Supra (MA 61)	9.83-12.85				□ 2,4		343042	553063	⊥ ○ 0,7
<u>2WD</u> ST, GT (AT 160, ST 162, ST 160) Exc. ST 165 <u>4WD</u>	8.85- 8.87		365058 365068 <sup>1)</sup>		□ 2,4		334007 L 334006 R		⊕ 1,7
<u>2WD</u> GT (AT 160, ST 162) Exc. ST 165 <u>4WD</u>	8.87- 9.89		365058 365068 <sup>1)</sup>		□ 2,4		334014 L 334013 R		⊕ 2,2
1) O.E.= 48510-20262, 48520-20252									

Toyota

\*Excel-G is a new name of SUPER  
Excel-G ist der neue Name für SUPER  
Excel-G est le nom nouveau pour SUPER



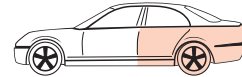
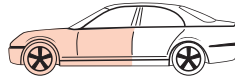

MODEL FAHRZEUG MODELE	YEAR JAHR ANNEE	FRONT/VORNE/AVANT				REAR/HINTEN/ARRIERE			
		PREMIUM Oil	EXCEL-G* Twin-tube Gas	GAS-A-JUST Mono-tube Gas		PREMIUM Oil	EXCEL-G* Twin-tube Gas	GAS-A-JUST Mono-tube Gas	
<b>Toyota (J)</b>									
<b>Celica</b>									
 1.6 STi (AT 180), 2.0 GTi (ST 182)	10.89- 94		365077		 2,2		334051 L 334050 R		 2,4
 2.0 Turbo (ST 185)	10.89- 94		365077		 2,2		334053 L 334052 R		 2,4
 1.8 (AT 200), 2.0 (ST 202)	94- 99		365092 <sup>1)</sup>				334126 L 334125 R		
 2.0 GT Four (ST 205)	94- 99						334128 L 334127 R		
1.8 (ZZT230)	8.99-10.99		334278 L 334277 R				341277 <sup>2)</sup>		
1.8 (ZZT230)	10.99- 8.00		334278 L 334277 R				341278 <sup>3)</sup>		
1.8 (ZZT23#)	8.00-		334278 L 334277 R				341278 <sup>3)</sup>		
1) O.E. = 48510-29235, -29236, 48520-29075, -29076      2)       3)									
<b>Celica Supra, Supra Exc.</b>									
2.8 (MA 61) 	12.81- 8.83	665037	365026 ▼ 365076		 2,4		343042	553063	 0,7
2.8 (MA 61) 	9.83-12.85				 2,4		343042	553063	 0,7
3.0-24V, 3.0-24V Turbo (MA 70) 	1.86- 5.93		341069				341070		
3.0-24V, 3.0-24V Turbo (JZA 80) 	5.93- 1.96			551069				551070	
<b>Corolla &amp; Sprinter (70-4.87)</b>									
(KE 20, TE 20 series) 1200, 1400	5.70- 3.74	663031	363018			443097	343035	553054	 0,6
(KE 26 V) 1200	5.70- 3.74	663031				443065			 0



MODEL FAHRZEUG MODELE	YEAR JAHR ANNEE	FRONT/VORNE/AVANT				REAR/HINTEN/ARRIERE			
		PREMIUM Oil	EXCEL-G* Twin-tube Gas	GAS-A-JUST Mono-tube Gas		PREMIUM Oil	EXCEL-G* Twin-tube Gas	GAS-A-JUST Mono-tube Gas	
<b>Toyota (J)</b>									
<b>Corolla &amp; Sprinter (70-4.87)</b>									
(TE 27 MQ, 27 MBQ) 1600 SR	3.72- 3.74	665021	365001			443097	343035	553054	
(KE 30, 40, 50, 60) 1200, 1300	4.74- 5.79	663031	363018			443068	343059	553055	
(TE 30, 40, 50, 60) 1400, 1600	4.74- 5.79	665022	365015		 3,0	443068	343059	553055	
(KE 36 V) 1200	4.74- 5.79	663031	363018			443098	343062	553030	
(TE 36 V) 1400	4.74- 5.79	665022	365015		 3,0	443098	343062	553030	
(KE 70, AE 70) 1300, 1500	6.79- 8.81	663032	363023		 3,0	443099	343036	553056	
(TE 70, TE 71, CE 70) 1600, 1800, 1800 Diesel	6.79- 8.81	665022	365015		 3,0	443099	343036	553056	
 1300 (KE 71 V, 72 V) 1300 (KE 73 G)	6.79- 8.81 4.82- 7.87	663032	363023		 3,0	443098	343062		
(TE 73 V) 1600 (OHC)	6.79- 8.81	665022	365015		 3,0	443098	343062		
(CE 71 V) 1800 Diesel	8.81- 7.87	665022	365015		 3,0	443098	343062		
(AE 80/81/82, EE 80) 1300, 1500, 1600	5.83- 4.85	663045	363039		 3,2		332012 L 332011 R		
(CE 80) 1800 Diesel Exc. Rough Road Package	5.83- 4.87	665047	365041		 3,2		332012 L 332011 R		
(AE 86) 1600 GT 16 V (Levin)	5.83- 4.87		365015		 3,0		343036	553056	
(AE 82) 1600 Compact GT 16 V	10.84- 4.87		365041		 3,2		332021		
(EE 80, AE 80, AE 82) 1300, 1600 Exc. GT-16V	5.85- 4.87		363059		 3,2		332012 L 332011 R		

\*Excel-G is a new name of SUPER  
 Excel-G ist der neue Name für SUPER  
 Excel-G est le nom nouveau pour SUPER

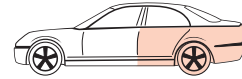
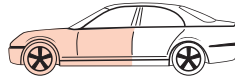

MODEL FAHRZEUG MODELE	YEAR JAHR ANNEE	FRONT/VORNE/AVANT				REAR/HINTEN/ARRIERE			
		PREMIUM Oil	EXCEL-G* Twin-tube Gas	GAS-A-JUST Mono-tube Gas		PREMIUM Oil	EXCEL-G* Twin-tube Gas	GAS-A-JUST Mono-tube Gas	
<b>Toyota (J)</b>									
<b>Corolla  (5.87- 4.97)</b>									
1300 ,1600 (EE 90, AE 92) Exc. 1600 GTi Exc. Rough Road Package	5.87- 92		363060 <sup>1)</sup> 333119 L 333118 R 				333052 L 333051 R 		
1)									
(AE 92) 1600 GTi	5.87- 92		365064 				333052 L 333051 R		
1800 Diesel (CE 90) Exc. Rough Road Package	5.87- 92		365064 				333052 L 333051 R		
Rough Road Package 1300 (EE 90), 1600 (AE 92) 1800 Diesel (CE 90) 	5.87- 92		365066				333052 L 333051 R		
(AE 95) 1600	10.87- 8.95		365066				343242		
1300 i (EE 100), 1400 i (EE 101) Exc. Rough Road Package	5.92- 4.97		333115 L 333114 R 				333117 L 333116 R		
1600 i (AE 101) 	5.92- 4.97		333115 L 333114 R 				333117 L 333116 R		
2000 Diesel (CE 100) Exc. Rough Road Package	5.92- 4.97		365091 				333117 L 333116 R		
Rough Road Package 1300 i (EE100), 2000 Diesel (CE 100) 	5.92- 4.97						333117 L 333116 R		
<b>Corolla  (  = JT153..., JTB53...),  (  = JT172..., JTB72... ) (4.97-9.01)</b>									
1300-12V (EE110) Exc. Rough Road Package	4.97- 9.01		333237 L <sup>1)</sup> 333236 R <sup>1)</sup>				332089 L <sup>4)</sup> 332088 R <sup>4)</sup>		
1300-16V, 1600-16V (EE111, AE111) 1400-16V, 1600-16V (ZZE111, ZZE112) Exc. Rough Road Package	4.97-10.99 10.99- 9.01		333237 L <sup>1)</sup> 333236 R <sup>1)</sup>				334179 L <sup>5)</sup> 334178 R <sup>5)</sup>		
<div style="display: flex; justify-content: space-around;"> <div style="text-align: center;"> <p>1), 2) ⇔ 3)</p> <p>1), 2) = 322 3) = 338</p> </div> <div style="text-align: center;"> <p>4) ⇔ 6)</p> <p>4) = φ 18 6) = φ 20</p> </div> <div style="text-align: center;"> <p>5) ⇔ 6)</p> <p>5) Lmax = 511 6) Lmax = 571</p> </div> </div>									

Toyota



MODEL FAHRZEUG MODELE	YEAR JAHR ANNEE	FRONT/VORNE/AVANT				REAR/HINTEN/ARRIERE			
		PREMIUM Oil	EXCEL-G* Twin-tube Gas	GAS-A-JUST Mono-tube Gas		PREMIUM Oil	EXCEL-G* Twin-tube Gas	GAS-A-JUST Mono-tube Gas	
<b>Toyota (J)</b>									
<b>Corolla  (  = JT153..., JTB53...),  (  = JT172..., JTB72... ) (4.97-9.01)</b>									
2000 Diesel   (CE110) 1800 Diesel   (WZE110) Exc. Rough Road Package	4.97-10.99 1.00- 9.01		334177 L <sup>2)</sup> 334176 R <sup>2)</sup>				334179 L <sup>5)</sup> 334178 R <sup>5)</sup>		
 ⊕ Rough Road Package 1300-12V/-16V, 1400-16V, 1600-16V 1800 Diesel, 2000 Diesel	4.97- 9.01		334187 L <sup>3)</sup> 334186 R <sup>3)</sup>				333117 L <sup>6)</sup> 333116 R <sup>6)</sup>		
1800-16V  (AE115)	4.97- 9.01		334187 L <sup>3)</sup> 334186 R <sup>3)</sup>				333287 L 333286 R		
<b>Corolla  (  = JT152..., JTB52...),  (  = JT164..., JTB64... ) (4.97-9.01)</b>									
 1300-16V, 1600-16V (EE111, AE111) 1400-16V, 1600-16V (ZZE111, ZZE112) Exc. Rough Road Package	4.97-10.99 10.99-		333237 L <sup>1)</sup> 333236 R <sup>1)</sup>				334179 L <sup>5)</sup> 334178 R <sup>5)</sup>		
 ⊕ Rough Road Package 1300-16V, 1400-16V, 1600-16V	4.97- 9.01		334187 L <sup>3)</sup> 334186 R <sup>3)</sup>				333117 L <sup>6)</sup> 333116 R <sup>6)</sup>		
2000 Diesel   (CE110) 1800 Diesel  (WZE110)	4.97-10.99 1.00- 7.01		334177 L 334176 R				334179 L 334178 R		
<p>1), 2) ⇔ 3)       4) ⇔ 6)       5) ⇔ 6) </p>									
<b>Corolla  (10.01-)</b>									
1.4 (ZZE120) 2.0TD (CDE120) Exc. Rough Road Package	10.01-		333359 L 333358 R				341816		
1.6  (ZZE121) Exc. Rough Road Package	10.01-		333359 L 333358 R				341816		
1.6  (ZZE121) Exc. Rough Road Package	10.01-		333359 L 333358 R				341322		
<b>Corolla  (10.01-)</b>									
1.4 (ZZE120) 1.6 (ZZE121) 2.0TD (CDE120) Exc. Rough Road Package	10.01-		333359 L 333358 R				341816		
<b>Corolla  (9.02-)</b>									
1.4 (ZZE120) 1.6 (ZZE121) 2.0TD (CDE120)	9.02-		334818 L 334817 R				341816		

\*Excel-G is a new name of SUPER  
Excel-G ist der neue Name für SUPER  
Excel-G est le nom nouveau pour SUPER

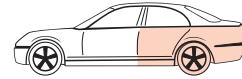
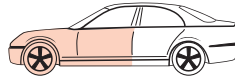

MODEL FAHRZEUG MODELE	YEAR JAHR ANNEE	FRONT/VORNE/AVANT				REAR/HINTEN/ARRIERE			
		PREMIUM Oil	EXCEL-G* Twin-tube Gas	GAS-A-JUST Mono-tube Gas		PREMIUM Oil	EXCEL-G* Twin-tube Gas	GAS-A-JUST Mono-tube Gas	
<b>Toyota (J)</b>									
<b>Corolla</b> (  =SB164... ) (4.97-11.01)									
1300-16V, 1600-16V (EE111, AE111)	9.98- 1.99		334177 L <sup>7)</sup> 334176 R <sup>7)</sup>				334179 L 334178 R		
1300-16V, 1600-16V (EE111, AE111)	1.99- 7.99		333237 L <sup>8)</sup> 333236 R <sup>8)</sup>				334179 L 334178 R		 4,8
1300-16V, 1600-16V (EE111, AE111)	7.99-11.99		334177 L <sup>7)</sup> 334176 R <sup>7)</sup>				334179 L 334178 R		
1400-16V, 1600-16V (ZZE111, ZZE112)	11.99-11.01		334177 L 334176 R				334179 L 334178 R		
1800 Diesel (WZE110)	12.99-11.01		334177 L 334176 R				334179 L 334178 R		
<p>7) ↔ 8)</p> <p>7) = φ 22 8) = φ 20</p>									
<b>Corolla</b> (1.02-)									
1.4 (ZZE120) 1.6 (ZZE121) 2.0TD (CDE120)	1.02-		334818 L 334817 R				341816		
<b>Corolla</b> (11.01-)									
1.4 (ZZE120) 1.6 (ZZE121) 1.8 (ZZE123) 2.0TD (CDE120) Exc. Rough Road Package	11.01-		334818 L 334817 R				341816		
<b>Corolla Verso</b> (9.01-)									
1.6 (ZZE121) 1.8 (ZZE122) 2.0TD (CDE120)	9.01-		333359 L 333358 R				341816		
<b>Corona</b>									
 1500, 1600, 1700, 1900 (RT 40/50/60/70/90 series, RT 82 S/84 S/95 S)	64- 3.73	443071	343037	553057		443068	343059	553055	
 1500, 1600 (PT 46 V/47 V, RT 46 V/47 V)	64- 1.70	443071	343037			443070	343060		
(RT 80/81/82/84) 1700	2.70- 7.73	443071	343037	553057		443068	343059	553055	

\*Excel-G is a new name of SUPER  
Excel-G ist der neue Name für SUPER  
Excel-G est le nom nouveau pour SUPER



MODEL FAHRZEUG MODELE	YEAR JAHR ANNEE	FRONT/VORNE/AVANT				REAR/HINTEN/ARRIERE			
		PREMIUM Oil	EXCEL-G* Twin-tube Gas	GAS-A-JUST Mono-tube Gas		PREMIUM Oil	EXCEL-G* Twin-tube Gas	GAS-A-JUST Mono-tube Gas	
<b>Toyota (J)</b>									
<b>Corona</b>									
(RT 86 V/87 V/88 V) 1600, 1700	2.70- 7.73	443071	343037			443072			
(RT 100/110/120, TT 100/1105/120 ) 1600, 1800, 2000	8.73- 78	443071	343037	553057		443073	343038	553028	
(RT 116) 1800	8.73- 78	443071	343037	553057		443100	343125	553058	
(RT 106 V/108 V, TT 106 V) 1600, 1800	8.73- 78	443071	343037	553057		443179	343214	553120	
(TT 130/131, RT 131/133) 1600, 1800, 2000	9.78-12.81	665021	365001			443102	343039	553041	
(TT 131/132, RT 132/133) 1800, 2000	9.78-12.81	665024	365005			443102	343039	553041	
(AT 140, ST 140) 1500, 1800	1.82-12.86	665021	365001			443102	343039	553041	
(CT 140) 1800 Diesel	1.82-12.86					443102	343039	553041	
(TT 142, RT 141) 1800, 2000	1.82-12.86	665024	365005				343042	553063	
(TT 137 V, RT 137 V) 1600, 1800	9.78-12.81	665021	365001			443103			
(TT 147 V, CT 147 V) 1600, 1800	1.82-12.86	665021	365001			443104	343040		
<b>Corona Mk II &amp; Cressida</b>									
(RT 60/70 series) 1600, 1700, 1900	9.68-12.71	443071	343037	553057		443070	343060	553060	
(RX 10/20, MX 10/20) 1800, 2000, 2300 SL, GSL, GSS	1.72-12.76	443071	343037	553057		443104	343040	553061	
(RX 16 V/17 V) 1800	2.71-12.76	443071	343037	553057		443179	343214	553120	
(RX 26/27/28, MX 27) 1800, 2000	1.72-12.76	443071	343037	553057		443070	343060	553060	

\*Excel-G is a new name of SUPER  
 Excel-G ist der neue Name für SUPER  
 Excel-G est le nom nouveau pour SUPER

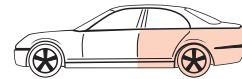
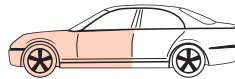

MODEL FAHRZEUG MODELE	YEAR JAHR ANNEE	FRONT/VORNE/AVANT				REAR/HINTEN/ARRIERE			
		PREMIUM Oil	EXCEL-G* Twin-tube Gas	GAS-A-JUST Mono-tube Gas		PREMIUM Oil	EXCEL-G* Twin-tube Gas	GAS-A-JUST Mono-tube Gas	
<b>Toyota (J)</b>									
<b>Corona Mk II &amp; Cressida</b>									
1800, 2000 (TX 40, MX 30/31/41, RX 30/31/40/41)	1.77- 8.80	665025	365016		□	443105	343041	553062	⊥ ○
(MX 43) 2600	1.77- 9.80	665025	365016		□			553063	⊥ ○
(RX 37 V, MX 35/45, TX 47) 1800, 2000	1.77-10.80	665025	365016		□	443068	343059		⊥ ○
(RX 63, GX 61, MX 61) 2000 GT, LG Touring	9.80- 8.82	665037	365026▼ 365076		□			553063	⊥ ○
(MX 61) 2000 GD, Turbo	10.81- 7.82	665038	365017		□			553063	⊥ ○
2000 GD Turbo (MX 61, GX 61) 2400 Turbo Diesel (LX 65)	8.82- 7.84 8.82- 7.84	665037	365026▼ 365076		□ 3,0			553063	⊥ ○
(SX 60) 1800	8.82- 7.84	665037	365026▼ 365076		□ 3,0		343041	553062	⊥ ○
(LX 60) 2200 D	9.80- 8.82	665038	365017		□	443105	343041	553062	⊥ ○
(LX 60) 2200 D	8.82- 7.84	665037	365026▼ 365076		□ 3,0	443105	343041	553062	⊥ ○
(TX/RX/GX/MX/LX 60) 1800, 2000	9.80- 8.82	665038	365017		□		343041	553062	⊥ ○
(GX 60 G, LX 60) 2000, 2200	11.80- 8.82	665038	365017		□	443102	343039		⊥ ○
(TX 67 V, LX 67 V) 1800, 2200 D	11.80- 8.82	665038	365017		□	443068	343059		⊥ ○
<b>Hi-Lux</b>									
RN 10/20 series	68- 8.78	443071	343037	553057	⊥ ⊕	444026		553060	○ ○
RN 30/35/40	9.78- 8.80	443108		553122	⊥ ⊕ 0,8	444026		553060	○ ○ 0,6
RN 36/39	9.78-10.83	443106	343195	553110	⊥ ⊕ 0,8	443107			○ ○ 0,6





MODEL FAHRZEUG MODELE	YEAR JAHR ANNEE	FRONT/VORNE/AVANT				REAR/HINTEN/ARRIERE			
		PREMIUM Oil	EXCEL-G* Twin-tube Gas	GAS-A-JUST Mono-tube Gas		PREMIUM Oil	EXCEL-G* Twin-tube Gas	GAS-A-JUST Mono-tube Gas	
<b>Toyota (J)</b>									
<b>Hi-Lux</b>									
 LN 30/40/41	12.79- 3.84	443108		553122	 0,8	444026		553060	 0,6
 LN 36/46	10.81-10.83	443106	343195	553110	 0,8	443183	343245	553111	 0,6
 YN/LN 50 series	11.83- 8.88	443214	343198	553117	 0,8	443217	343199	553118	 0,6
 YN/LN 60 Exc. VAN	11.83- 8.88	443106	343195	553110	 0,8	443241	343300	553160	 0,6
 LN/YN 85 LN 85	8.88-10.91 8.91-	443214	343198	553117	 0,8	443217	343199	553118	 0,6
 LN/YN 85 	10.91-	443214	343198	553117	 0,8	443259	343252	553209	 0,6
 LN/YN 90	8.88-10.91	443214	343198	553117	 0,8	443258	343251	553189	 0,6
 LN 105, YN 106	8.88-	443106	343195	553110	 0,8	443257L,R	343253L,R	553190L,R	 0,6
 RN106 LN/YN/RN110 LN108	8.89- 8.88- 8.91-	444103	344202	554069	 0,8	443257 L 443254 R	343253 L 343246 R	553190 L 553191 R	 0,6
LN145 LN150	8.97-	443214	343198	553117		443297		553233	
LN145	8.97-	443214	343198	553117		443298		553234	
LN165, LN170 RZN168, RZN173	8.97-		344202	554069			343300 L 343299 R	553160 L 553235 R	
<b>Land Cruiser</b>									
FJ, BJ 40 series	3.69- 1.75	444024		554039	 0,6	444026			 0,5
FJ, BJ 40 series BJ 44V	1.75- 4.86 10.81-10.85	444024		554039	 0,6	444012	344015	554041	 0,5

\*Excel-G is a new name of SUPER  
 Excel-G ist der neue Name für SUPER  
 Excel-G est le nom nouveau pour SUPER

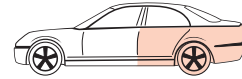
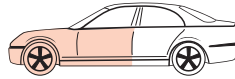

MODEL FAHRZEUG MODELE	YEAR JAHR ANNEE	FRONT/VORNE/AVANT				REAR/HINTEN/ARRIERE			
		PREMIUM Oil	EXCEL-G* Twin-tube Gas	GAS-A-JUST Mono-tube Gas		PREMIUM Oil	EXCEL-G* Twin-tube Gas	GAS-A-JUST Mono-tube Gas	
<b>Toyota (J)</b>									
<b>Land Cruiser</b>									
FJ, BJ 50 series	3.69- 7.80	444027		554042		444026			
BJ 60, HJ 60, FJ 60/62 WGV (Van Type)	8.80-10.85	444041	344217	554043		444012	344015	554041	
HJ 60/61, FJ 60/62 WGG (G Type)	8.80-10.85	444078	344218	554044		444012	344015	554041	
BJ 60, HJ 60/61, FJ 60/62 WGV (Van Type)	10.85-11.86	444041	344217	554043		444098 L 444097 R	344220 L 344219 R		
BJ 60, HJ 60/61, FJ 60/62 WGV (Van Type)	11.86- 8.87	444078	344218	554044		444098 L 444097 R	344220 L 344219 R		
HJ 60/61, FJ 62 WGG (G Type) Exc. ⊕ Tire 10 R 15-6	10.85- 8.87	444078	344218	554044		444098 L 444097 R	344220 L 344219 R		
HJ 60/61, FJ 62 WGG (G Type) ⊕ Tire 10 R 15-6	10.85- 8.87	444078	344218	554044		444098	344220		
FJ 62, HJ 60/61 Exc. ⊕ 7JJ x 15 wheel	8.87- 1.90		345008				345018		
FJ 62 GX, GV ⊕ 7JJ x 15 wheel HJ 60/61 GX, GV ⊕ 7JJ x 15 wheel	8.87- 1.90		345008				345015		
BJ 70/71/73 	11.84- 8.87	444114	344060	554055		444092	344216	554056	
BJ 70/71/73 	8.87- 1.90	444106	344207	554079		444092	344216	554056	
BJ 75 	11.84- 8.87	444114	344060	554055		444107	344061	554080	
BJ 75 	8.87- 1.90	444106	344207	554079		444107	344061		
RJ 70/73, LJ 70/73 	11.84- 8.87	444113	344213	554057		444116 L 444115 R	344215 L 344214 R	554059 L 554058 R	
RJ 70/73 LJ 70/73	8.87- 1.90	444113	344213	554057			345019 L 345018 R		



MODEL FAHRZEUG MODELE	YEAR JAHR ANNEE	FRONT/VORNE/AVANT				REAR/HINTEN/ARRIERE			
		PREMIUM Oil	EXCEL-G* Twin-tube Gas	GAS-A-JUST Mono-tube Gas		PREMIUM Oil	EXCEL-G* Twin-tube Gas	GAS-A-JUST Mono-tube Gas	
<b>Toyota (J)</b>									
<b>Land Cruiser</b>									
HZJ 70/73 PZJ 70/73	1.90- 1.90- 8.91	444110	344210	554081		444112	344212	554082	
PZJ 75 HZJ 75	1.90- 8.92 8.92-	444106	344207	554079		444107	344061	554080	
RJ 70/73, LJ 70/73/77 KZJ 70/73/77	1.90- 4.96 5.93- 4.96		344211	554076			345011	555005	
HDJ 80, HZJ 80, FJ 80 FZJ 80	1.90- 98 8.92- 98		345020				345010		
KZJ90 3.0 Diesel VZJ90 3.4	96-12.98		341232				344288		
KZJ90 3.0 Diesel VZJ90 3.4	1.99-		341232				344288		
KZJ95 3.0 Diesel VZJ95 3.4	96- 1.98		341232				344288		
KZJ95 3.0 Diesel VZJ95 3.4	2.98-		341232				344288		
DJ100 4.2 Diesel Turbo UZJ100 4.7	98-		345022				345023		
<b>Lexus GS300 Exc.  TEMS (  )</b>									
3000-24V 	(JZS147) 3.93- 8.97		341264				341265		
3000-24V 	(JZS160) 8.97-		341266				341267		
<b>Lexus IS200</b>									
2000-24V 	(GXE10) 1.99-		341262				341263		
<b>Lexus LS400 Exc.  TEMS (  )</b>									
4000-32V 	(UCF10) 12.89-10.94		341159				341268		
4000-32V 	(UCF20) 10.94-		341159				341269		

\*Excel-G is a new name of SUPER  
Excel-G ist der neue Name für SUPER  
Excel-G est le nom nouveau pour SUPER

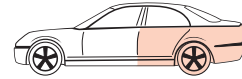
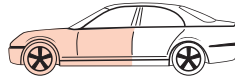

MODEL FAHRZEUG MODELE	YEAR JAHR ANNEE	FRONT/VORNE/AVANT				REAR/HINTEN/ARRIERE			
		PREMIUM Oil	EXCEL-G* Twin-tube Gas	GAS-A-JUST Mono-tube Gas		PREMIUM Oil	EXCEL-G* Twin-tube Gas	GAS-A-JUST Mono-tube Gas	
<b>Toyota (J)</b>									
<b>MR 2</b>									
1.6 (AW 10, 11)	6.84- 8.86		363045		□		363046		□
1.6 (AW 11)	9.86- 90		363045		□		365086		□
2.0-16V Incl. ⊕ ABS (SW20)	90- 00		365099		□		365100		□
1.8	(W3) 00-		333321 L 333320 R		⊕		334311 L 334310 R		⊕
<b>Passo </b>									
1500 (EL54)	8.95-		333210 L 333209 R		⊕		341191	551064	⊥ ⊕
<b>Picnic</b>									
(SXM 10, CXM 10) 2.0i, 2.2 TD	9.96-		334173 L 334172 R		⊕		343282		⊥ ○
<b>Previa</b>									
(TCR10),  (TCR20) 	5.90- 00		334094 L 334093 R		⊕		344226		○ T
(TCR11),  (TCR21) 	5.90- 00		334094 L 334093 R		⊕		344225		⊥
(R30)	4.00-		334285 L 334284 R		⊕		344308		⊥ ⊕
<b>Prius (Hybrid)</b>									
	8.00-		333361 L 333360 R		⊕		341321		⊥ ⊕
<b>Publica, Toyota 1000, 1201</b>									
(KP 30, 50 series) 1000, 1200	1.72- 78		363041		□			553082	⊕ ○
,  (KP 36, 37) 1000, 1200	1.72- 88	663027	363041		□	442011		552013	⊕ ○



MODEL FAHRZEUG MODELE	YEAR JAHR ANNEE	FRONT/VORNE/AVANT			⌚	REAR/HINTEN/ARRIERE			⌚
		PREMIUM Oil	EXCEL-G* Twin-tube Gas	GAS-A-JUST Mono-tube Gas		PREMIUM Oil	EXCEL-G* Twin-tube Gas	GAS-A-JUST Mono-tube Gas	
<b>Toyota (J)</b>									
<b>RAV 4</b>									
(SXA10), (SXA11)  Exc. 235-60	4.94- 1.98  1.98- 4.00		365093 <sup>1)</sup> 375035 <sup>1)</sup>  334242 L <sup>2)</sup> 334241 R <sup>2)</sup>  324022 L <sup>2)</sup> 324021 R <sup>2)</sup>		  		343272 <sup>3)</sup>      243033 <sup>3)</sup>	553195 <sup>3)</sup>      243033 <sup>3)</sup>	  
(SXA10) 235-60	8.96- 4.00		334242 L <sup>2)</sup> 334241 R <sup>2)</sup>  324022 L <sup>2)</sup> 324021 R <sup>2)</sup>				343313 <sup>4)</sup>   353017 <sup>4)</sup>	553195 <sup>4)</sup>   243033 <sup>4)</sup>	  
(SXA11) 235-60	8.96- 4.00		334252 L <sup>5)</sup> 334251 R <sup>5)</sup>  324024 L <sup>5)</sup> 324023 R <sup>5)</sup>				343314 <sup>6)</sup>   353018 <sup>6)</sup>	553195 <sup>6)</sup>   243033 <sup>6)</sup>	  
1.8 2.0 2.0TD (ZCA25) (ACA20) (CLA20)	5.00-		334332 L 334331 R				343272   243033	553195   243033	  
1.8 2.0 2.0TD (ZCA26) (ACA21) (CLA21)	5.00-						343272   243033	553195   243033	  
<div style="display: flex; justify-content: space-around;"> <div style="text-align: center;"> <p>1) </p> </div> <div style="text-align: center;"> <p>2) </p> </div> <div style="text-align: center;"> <p>3), 4) </p> </div> <div style="text-align: center;"> <p>5) </p> </div> <div style="text-align: center;"> <p>6) </p> </div> </div>									
<b>Starlet</b>									
(KP60, KP62, KP61) 1000, 1200, 1300	2.78-10.84	663029	363038		  3,2		342007   552006	552006   552006	  
(KP60V, KP62V, KP61V) 1000, 1200, 1300	10.78-10.84	663029	363038		  3,2	442009	552023   552023	552023   552023	  
(EP70, EP71, NP/NR70) 1000, 1300, 1500 Diesel	10.84-12.89		363047		  3,0		341048   551032	551032   551032	  
(EP80, EP81/82, NP80) 1000, 1300, 1500 Diesel	7.90- 4.94		333068 L 333067 R		  1,8		341082   551050	551050   551050	  
(EP80, EP81/82, NP80) 1000, 1300, 1500 Diesel	5.94- 1.96		333068 L 333067 R		  1,8		341191   551064	551064   551064	  

\* Excel-G is a new name of SUPER  
 Excel-G ist der neue Name für SUPER  
 Excel-G est le nom nouveau pour SUPER

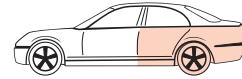
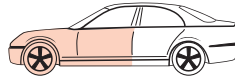

MODEL FAHRZEUG MODELE	YEAR JAHR ANNEE	FRONT/VORNE/AVANT				REAR/HINTEN/ARRIERE			
		PREMIUM Oil	EXCEL-G* Twin-tube Gas	GAS-A-JUST Mono-tube Gas		PREMIUM Oil	EXCEL-G* Twin-tube Gas	GAS-A-JUST Mono-tube Gas	
<b>Toyota (J)</b>									
<b>Starlet</b>									
(EP91) 1300	1.96-		333210 L 333209 R				341191	551064	
<b>Tercel &amp; Corsa</b>									
(AL 11, 12) 1300, 1500	7.78- 4.82	633001				442010			
(AL 20, 21) 1300, 1500	5.82- 8.84	663039	363030				332003 L 332002 R		
(4WD) (AL 25) 1500	8.82- 1.88		363037			443099	343036	553056	
<b>Town Ace /Model F /Space Cruiser</b>									
Town Ace (KR 10 V, TR 11 G)	76- 7.78					443089			
Town Ace (RR 10/20)	8.78-11.79					443194	343153	553106	
Town Ace (RR 10/21)	11.79-10.82					443194	343153	553106	
(TR 11/15) 	10.76- 1.81					443089			
(TR 15) 	1.81-10.82					443089			
 1800 (YR 20) 2000 (YR 21) 2000 Diesel (CR 21)	11.82- 8.84 8.84- 8.85 5.83- 8.84		343190				343193		
 2000 (YR 21) 2200 (YR 22)	8.85- 90 8.86- 90		343190				343192		
(4WD) (YR 31) 2200	8.86- 90		343277				343278		
<b>Yaris</b>									
1.0  (SCP10) 1.3  (NCP10) 1.4TD  (NLP10)	3.99- 5.02 3.99- 5.02 10.01- 5.02		333258 <u>323044</u>				343295 <u>353015</u>		

\*Excel-G is a new name of SUPER  
Excel-G ist der neue Name für SUPER  
Excel-G est le nom nouveau pour SUPER



MODEL FAHRZEUG MODELE	YEAR JAHR ANNEE	FRONT/VORNE/AVANT				REAR/HINTEN/ARRIERE			
		PREMIUM Oil	EXCEL-G* Twin-tube Gas	GAS-A-JUST Mono-tube Gas		PREMIUM Oil	EXCEL-G* Twin-tube Gas	GAS-A-JUST Mono-tube Gas	
<b>Toyota (J)</b>									
<b>Yaris</b>									
1.0  (SCP10) 1.3  (NCP10) 1.4TD  (NLP10)	5.02- 5.02- 5.02-		333368				343804		
			<u>323058</u>				<u>353015</u>		
1.5  (NCP13)	1.01- 5.02		333368				343805		
			<u>323058</u>				<u>353024</u>		
1.5  (NCP13)	5.02-		333368				343805		
			<u>323058</u>				<u>353024</u>		
<b>Yaris Verso</b>									
1.3  (NCP20, NCP22) 1.5  (NCP21) 1.4TD  (NLP20, NLP22) = Drum brake, Trommelbremse, Frein à tambour	8.99-		333278						
1.3  (NCP20, NCP22) 1.5  (NCP21) 1.4TD  (NLP20, NLP22) = Disk brake, Scheibenbremse, Frein à disque	8.99-		333278				343317		
<b>Toyota Commercial (J)</b>									
<b>Dyna 100</b>									
1800 (YH 81) 2400 Diesel (LH 80)	8.85- 5.95	444085	344058	554052			344099		
2400 Diesel (LY 100)	5.95-	444085	344058	554052			344099		
<b>Dyna 150</b>									
 1800 (YY 51/60) 2000 (YY 52/61) 2400 Diesel (LY 60)	8.85- 8.87 8.85- 8.87 8.85- 8.87	443260	343254			443262	343260		
 2000 (YY 61R), 2400 Diesel (LY 60R)	8.85- 8.87	443260	343254			443194	343153		
 2000 (YY 61L), 2400 Diesel (LY 60L)	8.85- 8.87	443260	343254			443285		553193	
 2800 Diesel (LY 61)	8.88- 5.95	443260	343254			443262	343260		
 2000 (YY 61), 2400 Diesel (LY 60) 2800 Diesel (LY 61)	8.87- 8.88 8.88- 5.95	443280		553203		443285		553193	

\*Excel-G is a new name of SUPER  
Excel-G ist der neue Name für SUPER  
Excel-G est le nom nouveau pour SUPER

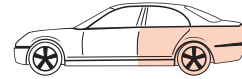
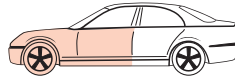

MODEL FAHRZEUG MODELE	YEAR JAHR ANNEE	FRONT/VORNE/AVANT				REAR/HINTEN/ARRIERE			
		PREMIUM Oil	EXCEL-G* Twin-tube Gas	GAS-A-JUST Mono-tube Gas		PREMIUM Oil	EXCEL-G* Twin-tube Gas	GAS-A-JUST Mono-tube Gas	
<b>Toyota Commercial (J)</b>									
<b>Dyna 150</b>									
2000 (YY 211), 2800 Diesel (LY 211)	5.95-	443260	343254		$\frac{\perp}{\bigcirc}$	443262	343260		$\bigcirc$ $\ominus$
2000 (YY 211R), 2800 Diesel (LY 211R)	5.95-	443260	343254		$\frac{\perp}{\bigcirc}$	443194	343153		$\bigcirc$ $\bigcirc$
2800 Diesel (LY 211L)	5.95-	443280		553203	$\frac{\perp}{\bigcirc}$	443285		553193	$\bigcirc$ $\bigcirc$
<b>Hi-Ace</b>									
(PH, RA, RH, LH series)	9.67-12.82	444022		554046	$\frac{\perp}{\bigcirc}$ $\ominus$	444023	344102	553084	$\bigcirc$ $\bigcirc$
(YH 50/61/71, LH 50/60/70)	12.82- 1.84	444085	344058	554052	$\frac{\perp}{\bigcirc}$ $\ominus$ 0,6	444084	344065		$\bigcirc$ $\bigcirc$ 0,4
(YH 51, LH 50/51)	12.82- 8.85	444085	344058	554052	$\frac{\perp}{\bigcirc}$ $\ominus$ 0,6	444087			$\frac{\perp}{\bigcirc}$ 0,4
LONG  (YH 61, LH 60)	12.82- 1.84	444085	344058	554052	$\frac{\perp}{\bigcirc}$ $\ominus$ 0,6	444086			$\bigcirc$ $\bigcirc$ 0,4
LONG  (YH 61, LH 60 series)	12.82- 1.84	444085	344058	554052	$\frac{\perp}{\bigcirc}$ $\ominus$ 0,6	444023	344102	553084	$\bigcirc$ $\bigcirc$ 0,4
1600 (RH11), 2200 Diesel (LH11)	11.82- 7.85	444022		554046	$\frac{\perp}{\bigcirc}$ $\ominus$	444023	344102	553084	$\bigcirc$ $\bigcirc$
(Commuter) 1800 (YH 50), 2400 Diesel (LH 51)	1.84- 8.85	444085	344058	554052	$\frac{\perp}{\bigcirc}$ $\ominus$ 0,6		344059	554053	$\bigcirc$ $\bigcirc$ 0,4
						O.E.= 48531-80041/-80044			
2000 Commuter (YH 61B) 2400 Diesel Van (LH 51V)	8.86- 8.88 9.85- 8.89	444085	344058	554052	$\frac{\perp}{\bigcirc}$ $\ominus$ 0,6		344059	554053	$\bigcirc$ $\bigcirc$ 0,4
2000 (YH 51V, YH 61V) 2400 Diesel (LH 61V) Exc. Fixed 9 seats (#H 51/61LV-QRJHW)	6.85- 8.89	444085	344058	554052	$\frac{\perp}{\bigcirc}$ $\ominus$ 0,6		344059	554053	$\bigcirc$ $\bigcirc$ 0,4
2000 (YH 51/61LV-QRJHW) 2400 Diesel (LH 61LV-QRJHW) ⊕ Fixed 9 seats	6.85- 8.89	444085	344058	554052	$\frac{\perp}{\bigcirc}$ $\ominus$ 0,6		344206		$\bigcirc$ $\bigcirc$ 0,4
2000 (YH 56V), 2200 (YH 66V) 2400 Diesel (LH 56V, LH 66V)	8.86- 8.89	444093	344201		$\frac{\perp}{\bigcirc}$ $\ominus$ 0,6		344100		$\bigcirc$ $\bigcirc$ 0,4

\*Excel-G is a new name of SUPER  
Excel-G ist der neue Name für SUPER  
Excel-G est le nom nouveau pour SUPER





MODEL FAHRZEUG MODELE	YEAR JAHR ANNEE	FRONT/VORNE/AVANT				REAR/HINTEN/ARRIERE			
		PREMIUM Oil	EXCEL-G* Twin-tube Gas	GAS-A-JUST Mono-tube Gas		PREMIUM Oil	EXCEL-G* Twin-tube Gas	GAS-A-JUST Mono-tube Gas	
<b>Toyota Commercial (J)</b>									
<b>Hi-Ace</b>									
2000 (RZH 102/112) 2400 (RZH 103/113) 2400 Diesel (LH 102/112)	8.89- 8.95	444104	344203			444123	344100		
(Commuter) (RZH 115) 2400	8.89- 5.92	444104	344203			444123	344100		
2400 (RZH 109/119) 2400 Diesel (LH 108/118)	8.89- 5.92	444093	344201			444105	344204		
2400 (RCH 12/22) 2700 (RCH 13/23) 2400 Diesel/Diesel Turbo (LXH 12/22)	8.95- 4.98 4.98- 8.96-		344203				344259		
2400 (RCH 18/28) 2700 (RCH 19/29) 2400 Diesel/Diesel Turbo (LXH 18/28)	8.96- 4.98 4.98- 8.96-		344201				344260		
<b>Life Ace</b>									
(KM 20, CM 20)	10.79- 9.85	443181	343154			443149	343213	553116	
(KM 20, CM 20)	10.79- 9.85	443181	343154			443150			
1500 (KM 30) 2000 Diesel (CM 30) 1500 (KM 31)	10.85- 1.92 8.88- 1.92 10.85- 8.86		343190				343267		
1500 (KM 36) 1800 Diesel (CM 35) 2000 Diesel (CM 36)	10.85- 1.92 10.85- 8.88 8.88- 1.92		343190				343196		
1500 (KR 21) 2200 (YR 22), 2000 Diesel (CR 21)	1.92- 5.94 1.92- 1.95		344255	554087			343192		
1500 (KR 27) 2200 (YR 29), 2000 Diesel (CR 27)	1.92- 5.94 1.92- 1.95		344255	554087			344102	553084	
(KM 67)	92-		344255	554087			344102	553084	
			O.E. = 48500 - 29585				O.E. = 48531 - 80129		
<b>Truck</b>									
Stout (RK 45/45 V/45 P/45 B, RK 100)	60- 66					444026		553060	

\*Excel-G is a new name of SUPER  
Excel-G ist der neue Name für SUPER  
Excel-G est le nom nouveau pour SUPER



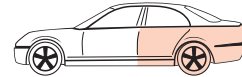
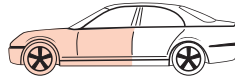

MODEL FAHRZEUG MODELE	YEAR JAHR ANNEE	FRONT/VORNE/AVANT				REAR/HINTEN/ARRIERE			
		PREMIUM Oil	EXCEL-G* Twin-tube Gas	GAS-A-JUST Mono-tube Gas		PREMIUM Oil	EXCEL-G* Twin-tube Gas	GAS-A-JUST Mono-tube Gas	
<b>Toyota Commercial (J)</b>									
<b>Truck</b>									
Stout, Stout Van (RK 40/40 V/43)	63- 68	443071	343037	553057	$\perp$ $\ominus$	444026		553060	$\circ$ $\circ$
Stout (RK 101)	67-			553061	$\perp$ $\circ$				
Stout (RK 110/111)	3.79-	443182			$\perp$ $\circ$	444023	344102		$\circ$ $\circ$
Coaster (RU 19, BU 19)	2.72- 7.77	444024			$\circ$ $\circ$	444025		553058	$\circ$ $\circ$
Coaster (RB 11/12/13, BB 10/11)	8.77- 4.82	444040	344114		$\circ$ $\circ$	444025		553058	$\circ$ $\circ$
Dyna  (RU/BU/JU 10) Dyna  (RU/JU 15)	5.70- 7.77 5.70- 1.72	444024			$\circ$ $\circ$	444025		553058	$\circ$ $\circ$
Dyna (RU 15, BU 15/20/30) Exc. low floor	2.72- 7.77	444024			$\circ$ $\circ$	444023	344102		$\circ$ $\circ$
Dyna (BU 20/30) Exc. low floor	77-11.84	444028	344062		$\perp$ $\circ$	444023	344102		$\circ$ $\circ$
Dyna low floor (BU 20/30)	77-11.84	444028	344062		$\perp$ $\circ$	444025		553058	$\circ$ $\circ$
Dyna (BU 35/36) Dyna (HU 50)	8.80- 8.84 4.82- 8.84	444028	344062		$\perp$ $\circ$	444023	344102		$\circ$ $\circ$
Dyna (YU 60/70, BU 60/62)	9.84-	444083		553204	$\perp$ $\circ$	444084	344065		$\circ$ $\circ$
Dyna 250 (BU 84)	86-	443260 O.E.=48511-29126	343254		$\perp$ $\circ$	443262 O.E.=48531-80060	343260		$\circ$ $\ominus$
<b>Vauxhall (GB)</b>									
<b>Astra</b>									
 	2.80- 8.84	665036	365025 375009 		$\perp$ 2,1	443134	343047	553075 243014	$\perp$ $\ominus$ 0,6

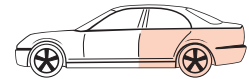

MODEL FAHRZEUG MODELE	YEAR JAHR ANNEE	FRONT/VORNE/AVANT			⚙️ ⌚	REAR/HINTEN/ARRIERE			⚙️ ⌚						
		PREMIUM Oil	EXCEL-G* Twin-tube Gas	GAS-A-JUST Mono-tube Gas		PREMIUM Oil	EXCEL-G* Twin-tube Gas	GAS-A-JUST Mono-tube Gas							
<b>Vauxhall (GB)</b>															
<b>Astra</b>															
ALL	2.80- 8.84	665036	365025		⏏	443135	343099	553137	⊖ ⊕ 0,6						
ALL	9.84- 91	665036	365025 375009		⏏	443134	343047	553075 243014	⊖ ⊕ 0,6						
ALL	9.84- 91	665036	365025		⏏	443135	343099	553137	⊖ ⊕ 0,6						
ALL 1.8 GTE	9.84- 91		365025 375009		⏏		343047	553075 243014	⊖ ⊕ 0,6						
ALL Exc. 1.8 i/2.0i SRi, GSi	8.91- 98	665066	365078 375034		⏏	443134	343047	553075 243014	⊖ ⊕ 0,6						
ALL 1.8 i/2.0i SRi, GSi	8.91- 98		365078 375034		⏏		343047	553075 243014	⊖ ⊕ 0,6						
ALL	8.91- 98	665066	365078		⏏	443135	343099	553137	⊖ ⊕ 0,6						
ALL Exc. Sport sus.	98-		334949 L 334948 R		⊕ ⊖		343306	553240	⊖ ⊕						
⊕ Sport sus. ALL	98-				⊕ ⊖		343306	553240	⊖ ⊕						
ALL Exc. Sport sus.	98-		334949 L 334948 R		⊕ ⊖		343307	553241	⊖ ⊕						
⊕ Sport sus. ALL	98-				⊕ ⊖		343307	553241	⊖ ⊕						
1) <table border="1"> <tr> <th>Model</th> <th>KYB</th> </tr> <tr> <td>1.2 / 1.3 / 1.4 / 1.6 ⊖ AF</td> <td>SM1300</td> </tr> <tr> <td>1.6 ⊕ AF / 1.8 / 2.0 / Diesel</td> <td>SM1307</td> </tr> </table>										Model	KYB	1.2 / 1.3 / 1.4 / 1.6 ⊖ AF	SM1300	1.6 ⊕ AF / 1.8 / 2.0 / Diesel	SM1307
Model	KYB														
1.2 / 1.3 / 1.4 / 1.6 ⊖ AF	SM1300														
1.6 ⊕ AF / 1.8 / 2.0 / Diesel	SM1307														

\* Excel-G is a new name of SUPER  
 Excel-G ist der neue Name für SUPER  
 Excel-G est le nom nouveau pour SUPER



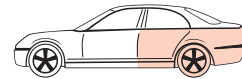
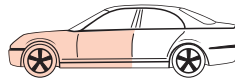

MODEL FAHRZEUG MODELE	YEAR JAHR ANNEE	FRONT/VORNE/AVANT				REAR/HINTEN/ARRIERE			
		PREMIUM Oil	EXCEL-G* Twin-tube Gas	GAS-A-JUST Mono-tube Gas		PREMIUM Oil	EXCEL-G* Twin-tube Gas	GAS-A-JUST Mono-tube Gas	
<b>Vauxhall (GB)</b>									
<b>Belmont</b>									
	86- 91	665036	365025 375009		□	443134	343047	553075 243014	⊥ ⊕
<b>Calibra</b>									
2.0 i (2WD), (4WD) Exc. 16V, 16V-Turbo	90- 98	665063	365071 375032		□ 2,2	443261	343259 353011	553182	⊥ ⊕ 0,7
2.0 i-16V (2WD), (4WD) 2.0 i-16V Turbo (4WD)	90- 98		365071 375032		□ 2,2		343259 353011	553182	⊥ ⊕ 0,7
<b>Campo/Brava </b>									
(2WD) (TFR Series)	92-	443190		553119	⊥ ⊕	443295		553230	○ ○
(4WD) (TFS Series)	92-	443216		553171	⊥ ⊕	443295		553230	○ ○
<b>Carlton, Viceroy, Omega Exc. </b>									
Carlton Viceroy Carlton	10.78- 2.82 10.80- 2.82 83- 86	665035	365007		□ 2,3	443027	343006	554011	⊥ ⊕ 0,7
Carlton Diesel	83- 86	665056			□ 2,3	443027	343006	554011	⊥ ⊕ 0,7
Carlton 	10.78- 82 83- 8.86	665035	365007		□ 2,3	443031	343007	554013	⊥ ⊕ 0,7
Carlton 1.8, 2.0, 2.4 i, 2.3 D, 2.3 TD	9.86- 94	634022 L 634021 R	334100 L 334099 R		⊕ 2,8	443234	343216 Exc.	553162	⊥ ⊕ 0,6
Carlton 2.6i, 3.0i, 3000	9.86- 94		334100 L 334099 R		⊕ 2,8		343216 Exc.	553162	⊥ ⊕ 0,6
Carlton 2.0, 2.3 D, 2.3 TD, 2.4 i	9.86- 94	634022 L 634021 R	334100 L 334099 R		⊕ 2,8	444095	344256 Exc.	554088	⊥ ⊕ 0,6

\*Excel-G is a new name of SUPER  
Excel-G ist der neue Name für SUPER  
Excel-G est le nom nouveau pour SUPER



MODEL FAHRZEUG MODELE	YEAR JAHR ANNEE	FRONT/VORNE/AVANT				REAR/HINTEN/ARRIERE			
		PREMIUM Oil	EXCEL-G* Twin-tube Gas	GAS-A-JUST Mono-tube Gas		PREMIUM Oil	EXCEL-G* Twin-tube Gas	GAS-A-JUST Mono-tube Gas	
<b>Vauxhall (GB)</b>									
<b>Carlton, Viceroy, Omega Exc. </b>									
Carlton 3.0 i	9.86- 94		334100 L 334099 R 915329			344256	554088		
 Exc. 2.5i, 3.0i	94-		334903 SM1304			343216	553162		
 2.5i, 3.0i	94-		334903			343216	553162		
 Exc. 2.5i, 3.0i	94-		334903 SM1304			344256	554088		
 2.5i, 3.0i	94-		334903			344256	554088		
<b>Cavalier, Vectra</b>									
 	8.75- 6.81	443026	343048 553009 244029			443027	343006	554011 244030	
 	8.81- 8.84	665042	365030			443230	343150	551033	
  No. 1003027 → No. 5000001 → No. 6000001 →	9.84- 88	665057	365054 915328			443230	343150	551033	
 	8.81- 8.84	665042	365030 915328			444141			
  No. 1003027 → No. 5000001 → No. 6000001 →	9.84- 88	665057	365054 915328			444141			
  Exc. 2000-16 V, 2.5-V6	9.88- 95	665063	365071 375032 915327  SM1301			443134	343047	553075 243014	
2000-16 V  (  =20XE, C 20XE) → NV199999 → N1999999 → N5999999	9.88- 92	665063	365071 915327  SM1301			443234	343216	553162	
2000-16 V  (  =20XE, C 20XE) P1000001 → P5000001 → P7000001 →	93- 95	665063	365071 375032 915327  SM1301			443134	343047	553075 243014	

\* Excel-G is a new name of SUPER  
Excel-G ist der neue Name für SUPER  
Excel-G est le nom nouveau pour SUPER

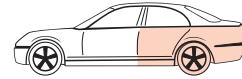
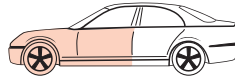

MODEL FAHRZEUG MODELE	YEAR JAHR ANNEE	FRONT/VORNE/AVANT				REAR/HINTEN/ARRIERE			
		PREMIUM Oil	EXCEL-G* Twin-tube Gas	GAS-A-JUST Mono-tube Gas		PREMIUM Oil	EXCEL-G* Twin-tube Gas	GAS-A-JUST Mono-tube Gas	
<b>Vauxhall (GB)</b>									
<b>Cavalier, Vectra</b>									
 2.5i -V6	93- 95		365071 <u>375032</u>		 2,1		343047	553075 <u>243014</u>	 0,6
							Exc.		
 1.8, 2.0i, 2.0i-16V, 2000-16V, 2.0i-16V Turbo	9.88- 95	665063	365071		 2,1	443234	343216	553162	 0,6
							Exc.		
<b>Chevette</b>									
 	6.76- 84	443026	343048	553009 <u>244029</u>	 0,5	443027	343006	554011 <u>244030</u>	 0,6
 	10.75- 84	443026	343048	553009	 0,5	443025	343081	553010	 0,6
<b>Corsa Combo </b>									
	94-	633831	333831		 1,3	443233	343227		
<b>Firenza, Magnum, VX, Victor, Viva</b>									
 Viva HB 162329 → Viva HC Firenza 1250, 1750, 2300 Magnum 1.8, 2.3	7.67- 70 8.70- 6.79 5.71- 6.75 9.73- 3.77	443121			 0,6	443043			 0,6
<b>Frontera</b>									
(52SU, 53MW, 5JMWW)  Incl. Sport	10.91- 9.95	444120	344227		 0,7	444122	344228		 0,4
(54/55/5B/5K SU,54/55/5B/5K MW)  Incl. Sport	9.95-		344227				344229		
<b>Monterey</b>									
(UBS)	92- 3.95		344279				344229		
(UBS)	4.95- 97		344279				344229		
<b>Nova, Corsa </b>									
Nova Exc. GTE, GSi	83- 2.93	633831	333831 <u>323034</u>		 1,3	443225	343265 <u>353012</u>	553155	 0,6



MODEL FAHRZEUG MODELE	YEAR JAHR ANNEE	FRONT/VORNE/AVANT				REAR/HINTEN/ARRIERE			
		PREMIUM Oil	EXCEL-G* Twin-tube Gas	GAS-A-JUST Mono-tube Gas		PREMIUM Oil	EXCEL-G* Twin-tube Gas	GAS-A-JUST Mono-tube Gas	
<b>Vauxhall (GB)</b>									
<b>Nova, Corsa</b>									
Nova GTE, GSi	83- 2.93		333831 323034				343265 353012	553155	
					1,3				⊥ ⊕ 0,6
Corsa Exc. GSi, Sport	3.93-	633831	333831 323034			443225	343265 353012	553155	
					1,3				⊥ ⊕ 0,6
Corsa GSi, Sport	3.93-		333831 323034				343265 353012	553155	
					1,3				⊥ ⊕ 0,6
<b>Royale, Senator Exc.</b>									
	10.78- 2.82 78- 8.87	665056					343044	554029	
					2,3				⊥ ⊕ 0,7
 2.3 TD, 2.6	9.87- 95	634022 L 634021 R	334100 L 334099 R			443234	343216 Exc.	553162	
					2,8				⊥ ⊕ 0,6
 2.5	9.87- 95	634022 L 634021 R	334100 L 334099 R			443234	343216 Exc.	553162	
					2,8				⊥ ⊕ 0,6
 3.0i, 3.0i-24 V	9.87- 95		334100 L 334099 R				343216 Exc.	553162	
					2,8				⊥ ⊕ 0,6
<b>Tigra</b>									
	94-		333831 323034				343265 353012	553155	
									⊥ ⊕
<b>Vectra B</b>									
1.6i, 1.8i, 1.7 TD, 2.0i, 2.0 Di Incl. 16V Exc. Sport sus.	9.95-		333913 L 333912 R				341907 Exc.		
			333716 L 333715 R		1,5				⊥ ⊕ 1,8
2.5i-V6 Exc. Sport sus.	9.95-		334601 L 334600 R				341907 Exc.		
									⊥ ⊕ 1,8
Sport sus. 	9.95-						341907 Exc.		
					1,5				⊥ ⊕ 1,8

\*Excel-G is a new name of SUPER  
Excel-G ist der neue Name für SUPER  
Excel-G est le nom nouveau pour SUPER

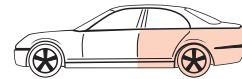
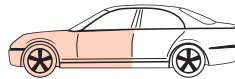

MODEL FAHRZEUG MODELE	YEAR JAHR ANNEE	FRONT/VORNE/AVANT				REAR/HINTEN/ARRIERE			
		PREMIUM Oil	EXCEL-G* Twin-tube Gas	GAS-A-JUST Mono-tube Gas		PREMIUM Oil	EXCEL-G* Twin-tube Gas	GAS-A-JUST Mono-tube Gas	
<b>Volkswagen (D)</b>									
<b>Corrado</b>									
1.8-16V 2.0-16V 1.8 G 60	(531)	4.89- 8.91- 9.88-	634950▼ 634810	334950▼ 334810 <u>324025</u> SM1700 <sup>2)</sup> SM1704 <sup>3)</sup>	⊕ 1,5		343258 <sup>1)</sup> (SP-001) 353013 <sup>1)</sup> (SP-001) 		⊥ ⊕ 0,9
VR 6	(531)	8.91-	634950▼ 634810	334950▼ 334810 <u>324025</u> SM1704	⊕ 1,5		343191 <sup>1)</sup> (SP-001) 353013 <sup>1)</sup> (SP-001) 		⊥ ⊕ 0,9
<b>Golf I, Jetta I   Exc. </b>									
Golf Jetta Exc. GTI, Turbo Diesel		73- 8.83 8.78- 2.84	663009 (RN-001)	363001 (RN-001) <u>373012</u> (RN-001) SM1706	⊥ 1,5	441018 <sup>4)</sup> 443172 <sup>6)</sup>	341007 <sup>4)</sup> 343169 <sup>6)</sup> <u>351007<sup>4)</sup></u>	551014 <sup>4)</sup>	⊥ ⊕ 0,5
Golf GTI, Turbo-Diesel Jetta GTI, Turbo-Diesel		9.76-12.83 9.76- 2.84		363001 (RN-001) <u>373012</u> (RN-001) SM1706	⊥ 1,5		341007 <sup>4)</sup> 343169 <sup>6)</sup> <u>351007<sup>4)</sup></u>	551014 <sup>4)</sup>	⊥ ⊕ 0,5
<b>Golf II, Jetta II   Exc. </b>									
<sup>(2WD)</sup> Golf Jetta → 1 G LW 320000 Exc. GTI, GTI 16 V, G 60		8.83-12.89 3.84-12.89	664014 <sup>5)</sup> (RN-001)	364014 <sup>5)</sup> (RN-001) <u>374006<sup>5)</sup></u> (RN-001) SM1701 633712 <u>333712</u> <u>324025</u> SM1701	⊥ ⊕ 1,5	443800 <sup>1)</sup> (SP-001)	343191 <sup>1)</sup> (SP-001) <u>353013<sup>1)</sup></u> (SP-001) 		⊥ ⊕ 0,5
<sup>(2WD)</sup> Golf /Jetta 1 G LW 320001 → Exc. GTI, GTI 16V,G60		1.90- 92	633950▼ 633712	333950▼ 333712 <u>324025</u> SM1701	⊕ 1,5	443800 <sup>1)</sup> (SP-001)	343191 <sup>1)</sup> (SP-001) <u>353013<sup>1)</sup></u> (SP-001) 		⊥ ⊕ 0,5
<sup>(2WD)</sup> Golf GTI Exc. 16V, G 60 Jetta GTI, GT 16V		1.84-12.89 3.84-12.89		364014 <sup>5)</sup> <u>374006<sup>5)</sup></u> (RN-001) SM1701 633950▼ <u>333950▼</u> 633712 <u>333712</u> <u>324025</u> SM1701	⊥ ⊕ 1,5		343191 <sup>1)</sup> (SP-001) <u>353013<sup>1)</sup></u> (SP-001) 		⊥ ⊕ 0,5
1)   (SP-001)      2) SM1700: -7.94 3) SM1704: 8.94-      4)        5) 6)									





MODEL FAHRZEUG MODELE	YEAR JAHR ANNEE	FRONT/VORNE/AVANT				REAR/HINTEN/ARRIERE			
		PREMIUM Oil	EXCEL-G* Twin-tube Gas	GAS-A-JUST Mono-tube Gas		PREMIUM Oil	EXCEL-G* Twin-tube Gas	GAS-A-JUST Mono-tube Gas	
<b>Volkswagen (D)</b>									
<b>Golf II , Jetta II   Exc. </b>									
(2WD) Golf GTI Exc. 16V, G60 Jetta GTi, GT 16V	1.90- 92 1.90- 92	633950▼ 633712	333950▼ 333712 <u>324025</u>		 1,5		343191 <sup>2)</sup> (SP-001) <u>353013</u> <sup>2)</sup> (SP-001)		 0,5
		915401	SM1701			915405			
(2WD) Golf GTI 16V	2.86-12.89		364014 <sup>1)</sup> <u>374006</u> <sup>1)</sup> (RN-001)			443235 <sup>2)</sup> (SP-001)	343258 <sup>2)</sup> (SP-001) <u>353013</u> <sup>2)</sup> (SP-001)		 0,5
		633950▼ 633712	333950▼ 333712 <u>324025</u>		 1,5				
		915401	SM1701				915405		
(2WD) Golf GTI 16V	1.90- 92	633950▼ 633712	333950▼ 333712 <u>324025</u>		 1,5	443235 <sup>2)</sup> (SP-001)	343258 <sup>2)</sup> (SP-001) <u>353013</u> <sup>2)</sup> (SP-001)		 0,5
		915401	SM1701				915405		
(2WD) Golf 1.8 GTI G60	10.89- 7.91	634950▼ 634810	334950▼ 334810 <u>324025</u>		 1,5	443235 <sup>2)</sup> (SP-001)	343258 <sup>2)</sup> (SP-001) <u>353013</u> <sup>2)</sup> (SP-001)		 0,5
		915401	SM1700				915405		
(4WD) Golf Syncro Exc. Rally, Country Jetta Syncro	2.86-12.89 8.87-12.89	664014 <sup>1)</sup> (RN-001)	364014 <sup>1)</sup> <u>374006</u> <sup>1)</sup> (RN-001)			443236 <sup>2)</sup> (SP-001)	343274 <sup>2)</sup> (SP-001)		 0,8
		633950▼ 633712	333950▼ 333712 <u>324025</u>		 1,5				
		915401	SM1701				915405		
(4WD) Golf Syncro Exc. Rally, Country Jetta Syncro	1.90- 92 1.90- 92	633950▼ 633712	333950▼ 333712 <u>324025</u>		 1,5	443236 <sup>2)</sup> (SP-001)	343274 <sup>2)</sup> (SP-001)		 0,8
		915401	SM1701						

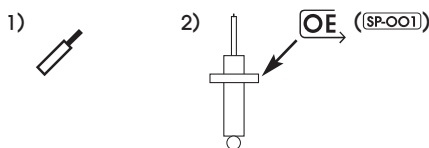

\*Excel-G is a new name of SUPER  
Excel-G ist der neue Name für SUPER  
Excel-G est le nom nouveau pour SUPER

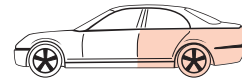
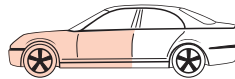

MODEL FAHRZEUG MODELE	YEAR JAHR ANNEE	FRONT/VORNE/AVANT				REAR/HINTEN/ARRIERE			
		PREMIUM Oil	EXCEL-G* Twin-tube Gas	GAS-A-JUST Mono-tube Gas		PREMIUM Oil	EXCEL-G* Twin-tube Gas	GAS-A-JUST Mono-tube Gas	

## Volkswagen (D)

### Golf III, Vento Exc.

<b>(2WD)</b> Golf, Vento 1.4i, 1.6i, 1.8i 1.9 Diesel, 1.9 Turbo Diesel, 1.9 TDI Incl. GT	(1H)	9.91- 98	633950▼ 633712	333950▼ 333712 <b>324025</b> 2)  SM1700 <sup>5)</sup> 3)  SM1701 <sup>5)</sup> SM1704 <sup>5)</sup>		443800 <sup>1)</sup> (SP-001)	343191 <sup>1)</sup> (SP-001) <b>353013<sup>1)</sup></b> (SP-001) 		⊥ ⊕ 1,1
<b>(2WD)</b> Golf, Vento 2.0 GTi, 2.0-16V GTi, 2.8V R6	(1H)	9.91- 98	634950▼ 634810	334950▼ 334810 <b>324025</b> SM1700 <sup>5)</sup> SM1701 <sup>5)</sup> SM1704 <sup>5)</sup>			343258 <sup>1)</sup> (SP-001) <b>353013<sup>1)</sup></b> (SP-001) 		⊥ ⊕ 1,1
<b>(4WD)</b> Golf Syncro 1.8 Exc. Country	(1H)	1.93- 98	633950▼ 633712	333950▼ 333712 <b>324025</b> SM1701					
<b>(4WD)</b> Golf, Vento Syncro 2.0, 2.9 VR 6, 1.9 TDI Exc. Country	(1H)	10.94- 98	634950▼ 634810	334950▼ 334810 <b>324025</b> SM1701					

### Golf III Variant

1.4, 1.6, 1.8 1.9D, 1.9TD, 1.9 TDI Exc. Syncro	(1H)	9.93- 98	633950▼ 633712	333950▼ 333712 <b>324025</b> 2)  SM1700 <sup>4)</sup> 3)  SM1701 <sup>4)</sup> SM1704 <sup>4)</sup>		441905			⊥ ⊕ 1,4
--	------	----------	-------------------	--	--	--------	--	--	---------------

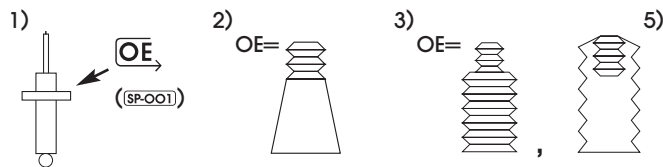

4)

	Year	KYB
ABD / ABS / AAM	9.91 - 6.95	SM1701
1Y / AAZ / 1Z	9.91 - 6.95	SM1700
AAA / ACC / AGG / ABF / 2E	9.91 - 6.95	SM1704
	7.95 - 8.97	SM1704

Model		Year	KYB
GOLF III	ABD / ABS / AAM	9.91 - 6.95	SM1701
	1Y / AAZ / 1Z	9.91 - 6.95	SM1700
	AAA / ACC / AGG / ABF / 2E	9.91 - 6.95	SM1704
		7.95 - 8.97	SM1704
VENTO	Exc. 2E / AAA	1.92 - 6.94	SM1701
	AAA	1.92 - 6.94	SM1704
	AEA / AEK / ADZ / AEP / ADY	7.94 - 6.95	SM1704
	ABD / ABU / AAM	7.94 - 6.95	SM1701
	ABS / 1Z / AAZ / 1Y / 2E / ABF	7.94 - 6.95	SM1700
	7.95 - 8.97	SM1704	



MODEL FAHRZEUG MODELE	YEAR JAHR ANNEE	FRONT/VORNE/AVANT			⚙️ ⌚	REAR/HINTEN/ARRIERE			⚙️ ⌚
		PREMIUM Oil	EXCEL-G* Twin-tube Gas	GAS-A-JUST Mono-tube Gas		PREMIUM Oil	EXCEL-G* Twin-tube Gas	GAS-A-JUST Mono-tube Gas	
<b>Volkswagen (D)</b>									
<b>Golf III Variant</b>									
2.0 Exc. Syncro	(1H) 9.93- 98	634950▼ 634810	334950▼ 334810 <u>324025</u> 915407  SM1700 <sup>1)</sup> SM1701 <sup>1)</sup> SM1704 <sup>1)</sup>		⊕ 1,5	441905			⊥ ⊕ 1,4
1)									
	Year	KYB							
ABD / ABS / AAM	9.91 - 6.95	SM1701							
1Y / AAZ / 1Z	9.91 - 6.95	SM1700							
AAA / ACC / AGG / ABF / 2E	9.91 - 6.95	SM1704							
	7.95 - 8.97	SM1704							
<b>Golf IV, Bora</b> ,									
 Golf, Bora 1.4,1.6 Exc. Sport sus.,	(1J) 9.97-	633208▼ 633713	333259▼ 333713 <u>324016</u> SM1708		⊕		343280▼ 343348	553206 <u>243037</u>	⊥ ⊕
 Golf, Bora 1.8,1.8, Turbo,2.0,2.3,1.9 SDI,1.9TDI Exc. Sport sus.,	(1J) 9.97-	634099▼ 634812	334220▼ 334812 <u>324016</u> 915415  SM1708		⊕		343280▼ 343348 915400	553206 <u>243037</u>	⊥ ⊕
 Golf, Bora ⊕ Sport sus.,	(1J) 9.97-		334220▼ 334812 <u>324016</u> 915415  SM1708		⊕		915400	553206 <u>243037</u>	⊥ ⊕
 Golf, Bora ⊕  , Exc. 2.8-V6	(1J) 9.97-	634099▼ 634812	334220▼ 334812 <u>324016</u> 915415  SM1708		⊕		915400		⊥ ⊕
 Golf, Bora 1.8, 2.3,1.9 TDI Exc. Sport sus.,  , 2.8-V6	(1J) 9.97-	634099▼ 634812	334220▼ 334812 <u>324016</u> SM1708		⊕		343310	553243 <u>243038</u>	⊕ ⊕
 Golf, Bora ⊕ Sport sus. Exc. 2.8-V6	(1J) 9.97-		334220▼ 334812 <u>324016</u> SM1708		⊕		343310	553243 <u>243038</u>	⊕ ⊕

\*Excel-G is a new name of SUPER  
 Excel-G ist der neue Name für SUPER  
 Excel-G est le nom nouveau pour SUPER



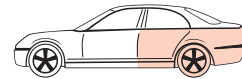
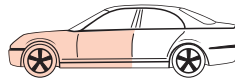

MODEL FAHRZEUG MODELE	YEAR JAHR ANNEE	FRONT/VORNE/AVANT				REAR/HINTEN/ARRIERE			
		PREMIUM Oil	EXCEL-G* Twin-tube Gas	GAS-A-JUST Mono-tube Gas		PREMIUM Oil	EXCEL-G* Twin-tube Gas	GAS-A-JUST Mono-tube Gas	
<b>Volkswagen (D)</b>									
<b>Golf IV, Bora</b>									
<b>4WD</b> Golf, Bora ⊕  , <b>ALL</b> Exc. 2.8-V6	(1J)	9.97-	634099▼ 634812	334220▼ 334812			343301		
SM1708									
<b>Golf IV Variant, Bora Variant</b>									
<b>2WD</b> Golf, Bora 1.4, 1.6 Exc. Sport sus.,	(1J)	99-	633208▼ 633713	333259▼ 333713			343298	553232	
SM1708									
<b>2WD</b> Golf, Bora 2.0, 2.3, 1.9 SDI, 1.9TDI Exc. Sport sus.,	(1J)	99-	634099▼ 634812	334220▼ 334812			343298	553232	
SM1708									
<b>2WD</b> Golf, Bora ⊕ Sport sus., <b>ALL</b>	(1J)	99-		334220▼ 334812				553206	
SM1708									
<b>2WD</b> Golf, Bora ⊕  , <b>ALL</b>	(1J)	99-	634099▼ 634812	334220▼ 334812					
SM1708									
<b>4WD</b> Golf, Bora 2.3, 1.9 TDI Exc. Sport sus.,  , 2.8-V6	(1J)	99-	634099▼ 634812	334220▼ 334812			343310	553243	
SM1708									
<b>4WD</b> Golf, Bora ⊕ Sport sus. <b>ALL</b> Exc. 2.8-V6	(1J)	99-		334220▼ 334812			343310	553243	
SM1708									
<b>4WD</b> Golf, Bora ⊕  , <b>ALL</b> Exc. 2.8-V6	(1J)	99-	634099▼ 634812	334220▼ 334812			344301		
SM1708									
<b>Golf Cabrio</b>									
Golf I <b>ALL</b>	(155)	76- 93	663009 <b>RN-001</b>	363001 <b>RN-001</b> 373012 <b>RN-001</b>			441018 <sup>1)</sup> 443172 <sup>2)</sup>	341007 <sup>1)</sup> 343169 <sup>2)</sup> 351007 <sup>1)</sup>	
SM1706									
<p>1)  <b>KYB</b></p> <p>2)  <b>OE</b>, (<del>SP/001</del>)</p>									



MODEL FAHRZEUG MODELE	YEAR JAHR ANNEE	FRONT/VORNE/AVANT				REAR/HINTEN/ARRIERE				
		PREMIUM Oil	EXCEL-G* Twin-tube Gas	GAS-A-JUST Mono-tube Gas		PREMIUM Oil	EXCEL-G* Twin-tube Gas	GAS-A-JUST Mono-tube Gas		
<b>Volkswagen (D)</b>										
<b>Golf Cabrio</b>										
Golf III  Incl. Sport sus.	(1H)	9.93- 2.98	634950▼ 634810	334950▼ 334810  324025		+	443800 <sup>1)</sup> (SP-001)	343191 <sup>1)</sup> (SP-001)  353013 <sup>1)</sup> (SP-001)		
Golf IV  Incl. Sport sus.	(1H)	3.98-	634950▼ 634810	334950▼ 334810  324025		+	443800 <sup>1)</sup> (SP-001)	343191 <sup>1)</sup> (SP-001)  353013 <sup>1)</sup> (SP-001)		
1)   (SP-001)										
<b>Käfer/Beetle/Coccinelle/Kefer</b>										
Type I ( swing axle) 1200, 1300, 1300 A, 1500, 1500 A		8.65- 79	443046	343088	553019		443045	343087	553017	
						1,3				0,5
Buggy 1300, 1500 Chassis		70- 79			553019				553017	
						1,3				0,5
Type I ( double articulated axle) 1300, 1300 A, 1500, 1500 A		5.67- 79	443046	343088	553019		443047	343053	553018	
						1,3				0,5
Buggy ( double articulated axle) 1300, 1300 A, 1500, 1500 A		70- 79			553019				553018	
						1,3				0,5
Type I 1302, S, LS 1303, S		8.70- 7.73 9.72- 7.73	663007	363012			443047	343053	553018	
						2,6				0,5
Type I 1303		8.73- 4.75	663008	363002			443047	343053	553018	
						2,6				0,5
Type III 1600, A, L, TL Incl.		8.67- 73	443044	343086	553016		443047	343053	553018	
						0,5				0,5
<b>Lupo</b>										
1.0, 1.4, 1.4TDi, 1.7SDi	(6X)	98-	633950▼ 633712	333950▼ 333712  324025		+		343309		
						1,5				

Volkswagen

\*Excel-G is a new name of SUPER  
Excel-G ist der neue Name für SUPER  
Excel-G est le nom nouveau pour SUPER



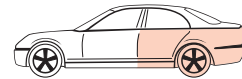
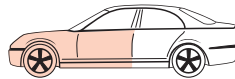

MODEL FAHRZEUG MODELE	YEAR JAHR ANNEE	FRONT/VORNE/AVANT				REAR/HINTEN/ARRIERE			
		PREMIUM Oil	EXCEL-G* Twin-tube Gas	GAS-A-JUST Mono-tube Gas		PREMIUM Oil	EXCEL-G* Twin-tube Gas	GAS-A-JUST Mono-tube Gas	
<b>Volkswagen (D)</b>									
<b>Lupo</b>									
1.6GTI (6X)	98-	633950▼ 633712	333950▼ 333712 <u>324025</u>		⊕ 1,5		343309		⊖
<b>New Beetle (1C, 9C)</b>									
	1.98-		334220▼ 334812 <u>324016</u>		⊕		343280▼ 343348	553206 <u>243037</u>	⊖
SM1708									
<b>Passat, Santana Exc. </b>									
Passat	7.73-10.80	664001	364001		⊖ 2,6	443048		554019	⊖ 0,5
Passat Variant	73- 2.81	664001	364001		⊖ 2,6	443049		554018	⊖ 0,5
Passat Passat Variant Santana  →32D155757	11.80- 3.83 3.81- 83 82- 3.83	665030 	365008  <u>375008</u> 		⊖ 2,6	443164 <sup>3)</sup> 	343043 <sup>3)</sup> 	551039 <sup>1)</sup>	⊖ 1,1
SM1702									
 Passat Passat Variant Santana  32D155758→	4.83- 3.88	665030 	365008  <u>375008</u> 		⊖ 2,6	443209 <sup>3)</sup> 	343206 <sup>3)</sup> 	551038 <sup>1)</sup>	⊖ 1,1
SM1702									
Syncro	8.84- 8.88		365008  <u>375008</u> 		⊖ 2,6			551063 <sup>1)</sup>	⊖ 1,4
SM1702									
Passat  Variant Exc. 2.8-VR6,	4.88- 7.91 6.88- 7.91	665064 <sup>2)</sup> 	365070 <sup>2)</sup> 		⊖ 1,7	443246 <sup>3)</sup> 	343223 <sup>3)</sup> 		⊖ 1,7
SM1700									
		634950▼ 634810	334950▼ 334810 <u>324025</u>		⊕				
SM1700									
Passat , Variant →P-026435 Exc. 2.8-VR6,	8.91- 92	634950▼ 634810	334950▼ 334810 <u>324025</u>		⊕ 1,5	443246 <sup>3)</sup> 	343223 <sup>3)</sup> 		⊖ 1,7
SM1700									
<p>1)  </p> <p>2) </p> <p>3)   (  )</p>									



MODEL FAHRZEUG MODELE	YEAR JAHR ANNEE	FRONT/VORNE/AVANT			⚙️ ⌚	REAR/HINTEN/ARRIERE			⚙️ ⌚
		PREMIUM Oil	EXCEL-G* Twin-tube Gas	GAS-A-JUST Mono-tube Gas		PREMIUM Oil	EXCEL-G* Twin-tube Gas	GAS-A-JUST Mono-tube Gas	
<b>Volkswagen (D)</b>									
<b>Passat, Santana Exc.</b>									
Passat (2WD) ALL, Variant  ALL P-026436 → Exc. 2.8-VR6,	92- 96	634951 ▼ 634811	334951 ▼ 334811		⊕ 1,5	443246 <sup>3)</sup> (SP-001)	343223 <sup>3)</sup> (SP-001)		⊥ ⊕ 1,7
		915407  SM1704				915408			
2.8 VR6 Exc. Syncro,	8.91- 96	634951 ▼ 634811	334951 ▼ 334811		⊕ 1,5	443246 <sup>3)</sup> (SP-001)	343223 <sup>3)</sup> (SP-001)		⊥ ⊕ 1,7
		915407  SM1704				915408			
Passat Syncro (4WD) 1.8 G60/2.0 1.8 G60/2.0	9.89- 7.91 10.90- 7.91	665064 <sup>2)</sup> (RN-002)	365070 <sup>2)</sup> (RN-002)		⊥			551063 <sup>1)</sup>	⊥ ⊕ 1,7
		SM1700							
		634950 ▼ 634810	334950 ▼ 334810		⊕ 1,5				
		324025  SM1700							
<b>Passat Exc.</b>									
Passat Syncro (4WD)  1.8-G60, 2.0 → P-026435	8.91- 92	634950 ▼ 634810	334950 ▼ 334810		⊕ 1,5			551063 <sup>1)</sup>	⊥ ⊕ 1,7
		SM1700							
Passat Syncro (4WD)  1.8-G60, 2.0 P-026436 →	92- 96	634951 ▼ 634811	334951 ▼ 334811		⊕ 1,5			551063 <sup>1)</sup>	⊥ ⊕ 1,7
		SM1704							
2.8 VR6 Syncro (4WD)  Exc.	8.91- 96	634951 ▼ 634811	334951 ▼ 334811		⊕ 1,5			551063 <sup>1)</sup>	⊥ ⊕ 1,7
		SM1704							
(2WD)  ALL Exc. Sport sus.	97-10.00		341207 <sup>4)</sup> 341904 <sup>1)</sup>		⊥ ⊗		343281	553207	⊥ ⊕
		915708					Exc.		
(2WD) ⊕ Sport sus.  ALL	97-10.00		341207 <sup>4)</sup>		⊥ ⊗			553207	⊥ ⊕
		915708						Exc.	
(4WD)  ALL Incl. Sport sus.	97-10.00		341207 <sup>4)</sup>		⊥ ⊗				
		915708							
(2WD)  ALL Exc. Sport sus.	(3BG) 11.00-		341273 <sup>4)</sup>		⊥ ⊗		343281	553207	⊥ ⊕
							Exc.		
1)	2)	3)	4)						

Volkswagen

\* Excel-G is a new name of SUPER  
Excel-G ist der neue Name für SUPER  
Excel-G est le nom nouveau pour SUPER



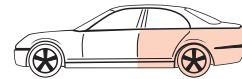
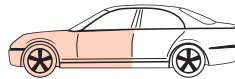

MODEL FAHRZEUG MODELE	YEAR JAHR ANNEE	FRONT/VORNE/AVANT				REAR/HINTEN/ARRIERE			
		PREMIUM Oil	EXCEL-G* Twin-tube Gas	GAS-A-JUST Mono-tube Gas		PREMIUM Oil	EXCEL-G* Twin-tube Gas	GAS-A-JUST Mono-tube Gas	
<b>Volkswagen (D)</b>									
<b>Passat Exc.</b>									
Sport sus. (3BG) 11.00- 			341273 <sup>2)</sup>					553207 Exc.	
Incl. Sport sus. (3BG) 11.00- 			341273 <sup>2)</sup>						
<b>Passat +</b>									
Syncro 	8.84- 8.88		365008  375008 					551063 <sup>1)</sup>	
Syncro 1.8-G60, 2.0	9.89- 92		334950▼ 334810  324025						
Syncro 1.8-G60, 2.0	92- 96		334951▼ 334811						
<b>Polo, Derby</b>									
Polo (Exc. G40) Derby	75- 94 7.76- 86	663035 	363043   373025 			441019 <sup>1)</sup> 443165 <sup>2)</sup>	341023 <sup>1)</sup> 343165 <sup>2)</sup>  351004 <sup>1)</sup>	551015 <sup>1)</sup>	
 1.0,1.05,1.3,1.4,1.6,1.7SDI,1.9D,1.9SDI	9.94-10.99	633950▼ 633712	333950▼ 333712  324025				343274 <sup>2)</sup>  353021		
 1.6 GTI	99-						343274 <sup>2)</sup>  353021		
Classic 1.4, 1.6, 1.7 SDI	95-	633950▼ 633712	333950▼ 333712  324025				343274 <sup>2)</sup>  353021		
1)        2) 3)  → 6KX610000      4)  → 6KX610000 →									

Volkswagen





MODEL FAHRZEUG MODELE	YEAR JAHR ANNEE	FRONT/VORNE/AVANT				REAR/HINTEN/ARRIERE			
		PREMIUM Oil	EXCEL-G* Twin-tube Gas	GAS-A-JUST Mono-tube Gas		PREMIUM Oil	EXCEL-G* Twin-tube Gas	GAS-A-JUST Mono-tube Gas	
<b>Volkswagen (D)</b>									
<b>Polo, Derby</b>									
Classic 1.9 SDI, 1.9 TDI	95-	634950▼ 634810	334950▼ 334810 <b>324025</b> SM1704 <sup>2)</sup> SM1707 <sup>3)</sup>		 1,5		343274 <sup>1)</sup> <b>353021</b> <b>915419</b>		 ⊥ ⊕
<b>Polo Variant</b>									
1.4,1.6 1.7 SDI,1.9 SDI	97-	633950▼ 633712	333950▼ 333712 <b>324025</b> SM1704 <sup>2)</sup> SM1707 <sup>3)</sup>		 1,5	443296 <sup>1)</sup>	343297 <sup>1)</sup> <b>915419</b>		 ⊥ ⊕
1.9 TDI (66kw,81kw)	97-	634950▼ 634810	334950▼ 334810 <b>324025</b> SM1704 <sup>2)</sup> SM1707 <sup>3)</sup>		 1,5	443296 <sup>1)</sup>	343297 <sup>1)</sup> <b>915419</b>		 ⊥ ⊕
<b>Scirocco</b>									
 Exc. GTI,GLI,GTX	74- 92	663009 <b>RN-001</b>	363001 <b>RN-001</b> 373012 <b>RN-001</b> <b>915402</b> SM1706		 1,5	441018 <sup>4)</sup> 443172 <sup>5)</sup>	341007 <sup>4)</sup> 343169 <sup>5)</sup> <b>351007<sup>4)</sup></b> <b>915700<sup>6)</sup></b>	551014 <sup>4)</sup>	 ⊥ ⊕ 0,5
GTI,GLI,GTX Exc. 16V	74- 92		363001 <b>RN-001</b> 373012 <b>RN-001</b> <b>915402</b> SM1706		 1,5		341007 <sup>4)</sup> 343169 <sup>5)</sup> <b>351007<sup>4)</sup></b> <b>915700<sup>6)</sup></b>	551014 <sup>4)</sup>	 ⊥ ⊕ 0,5
1)   2)  → 6KX610000 3)  → 6KX610000 → 4)   5)   (SPORT) 6) for 443172/343169									
<b>Sharan (7M)</b>									
,  Incl. Sport sus.,	9.95-		334947 SM1704		 ⊥ ⊕		343319	553244	 ⊕ ⊕
<b>Taro</b>									
 1.8, 2.2, 2.4 Diesel	2.89-10.91	443214	343198	553117	 ⊥ ⊕ 0,8	443217	343199	553118	 ○ ○ 0,8

\*Excel-G is a new name of SUPER  
Excel-G ist der neue Name für SUPER  
Excel-G est le nom nouveau pour SUPER

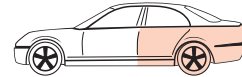
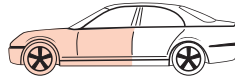

MODEL FAHRZEUG MODELE	YEAR JAHR ANNEE	FRONT/VORNE/AVANT				REAR/HINTEN/ARRIERE			
		PREMIUM Oil	EXCEL-G* Twin-tube Gas	GAS-A-JUST Mono-tube Gas		PREMIUM Oil	EXCEL-G* Twin-tube Gas	GAS-A-JUST Mono-tube Gas	
<b>Volkswagen (D)</b>									
<b>Taro</b>									
 1.8, 2.2, 2.4 Diesel	10.91-	443214	343198	553117	 0,8	443259	343252	553209	 0,8
 	2.89-	443106	343195	553110		443257 L,R	343253 L,R	553190 L,R	 0,8
 	2.89-	444103	344202	554069	 0,7	443257 L 443254 R	343253 L 343246 R	553190 L 553191 R	
<b>Type 181</b>									
Type 181 Jagdwagen	10.72-					443047	343053		
<b>Volkswagen Commercial (D)</b>									
<b>Golf Caddy</b>									
 	11.82- 95	663009 	363001 			441074			
					1,5				1,0
<b>Polo Caddy </b>									
1.4,1.6 (9K) 1.9 SD, 1.9 SDI, 1.9 TDI (42kw,66kw)	96-	633950▼ 633712	333950▼ 333712  324025		 1,5	443287		553231	
<b>Transporter, Bus, Caravelle, Multivan</b>									
Type II 	65- 5.67	443045	343087			443045	343087		
Type II 	6.67- 6.69	443044	343086			444002	344031	554060	
Type II 	7.69- 78	443051	343181	553132		444002	344031	554060	
Type II 	12.73- 79	443052				443053			



MODEL FAHRZEUG MODELE	YEAR JAHR ANNEE	FRONT/VORNE/AVANT				REAR/HINTEN/ARRIERE			
		PREMIUM Oil	EXCEL-G* Twin-tube Gas	GAS-A-JUST Mono-tube Gas		PREMIUM Oil	EXCEL-G* Twin-tube Gas	GAS-A-JUST Mono-tube Gas	
<b>Volkswagen Commercial (D)</b>									
<b>Transporter, Bus, Caravelle, Multivan</b>									
Type II (2WD) 	80- 7.90	445019	345006	551049		445020		554066	
Type IV (T4) Incl. Syncro (4WD) Caravelle, Multivan 	9.90- 93-	444119	344261				345900		
<b>Transporter LT Series</b>									
 LT 28/31/35 →28D007273	75-11.82	444050				444051			
 LT 28/28 D/31/31 D/35/35 D 28D007274→	83- 96	444050				444096			
 LT28 (1350kg - 1600kg) LT35 (1350kg - 1600kg) Incl.	5.96-		335915			444161			
 LT35 (1750kg) Incl.	5.96-		335914			444161			
 LT46 (1350kg - 1600kg) Incl.	5.96-		335915						
 LT46 (1750kg)	5.96-		335914						
<b>Volvo (S)</b>									
<b>66</b>									
DAF 66 Volvo 66	72- 76-	665009				443063			
<b>242, 244, 245, 264, 265, 240, 260 Series </b>									
 Exc. GLT, GLE, Turbo	74- 93	665008	365006			443062	343010	554021	
					1,7				
GLT, GLE, Turbo	9.80- 93					443062	343010	554021	
<b>300 Series</b>									
343, 345 340, 360	76- 8.82 82-	665010	365065			443050	343090	553157	
					1,8				

\* Excel-G is a new name of SUPER  
Excel-G ist der neue Name für SUPER  
Excel-G est le nom nouveau pour SUPER

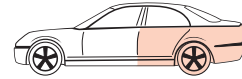
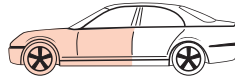

MODEL FAHRZEUG MODELE	YEAR JAHR ANNEE	FRONT/VORNE/AVANT				REAR/HINTEN/ARRIERE			
		PREMIUM Oil	EXCEL-G* Twin-tube Gas	GAS-A-JUST Mono-tube Gas		PREMIUM Oil	EXCEL-G* Twin-tube Gas	GAS-A-JUST Mono-tube Gas	
<b>Volvo (S)</b>									
<b>400 Series</b>									
440 (KX) 460 (LX)	8.88- 8.89-	633123 L 633122 R	333101 L 333100 R			443252	343243	553169	
					2,3				
480 (EX)	85-	633124	333102				343243	553169	
					2,3				
<b>740, 760 </b>									
 → 81679	2.82- 4.84					444082	344056	554054	
					1,7		Exc.		0,4
Exc. Turbo, Turbo -16V 81680→	5.84- 7.87	665055	365053			444082	344056	554054	
					1,7		Exc.		0,4
Turbo  Exc. Turbo -16V 81680→	5.84- 7.87		365053				344056	554054	
					1,7		Exc.		0,4
740 Exc. Turbo, Turbo -16V	8.87- 92	665055	365053			444082	344056	554054	
					1,7		Exc.		0,4
740 Turbo Exc. Turbo -16V	8.87- 92		365053				344056	554054	
					1,7		Exc.		0,4
760 Exc. Turbo	8.87- 92	665055	365053				OE =		
					1,7				
740 Turbo -16V, 760 Turbo 	8.87- 92		365053				OE =		
					1,7				
<b>740, 745, 760 </b>									
 Exc. Turbo	2.85- 92	665055	365053			444082	344056	554054	
					1,7		Exc.		0,4
 Turbo	2.85- 92		365053				344056	554054	
					1,7		Exc.		0,4
<b>780 </b>									
 Exc. Turbo	85- 7.87	665055	365053			444082	344056	554054	
					1,7		Exc.		0,4
 Turbo	85- 7.87		365053				344056	554054	
					1,7		Exc.		0,4
 Exc. Turbo	8.87- 91	665055	365053				OE =		
					1,7				



MODEL FAHRZEUG MODELE	YEAR JAHR ANNEE	FRONT/VORNE/AVANT				REAR/HINTEN/ARRIERE			
		PREMIUM Oil	EXCEL-G* Twin-tube Gas	GAS-A-JUST Mono-tube Gas		PREMIUM Oil	EXCEL-G* Twin-tube Gas	GAS-A-JUST Mono-tube Gas	
<b>Volvo (S)</b>									
<b>780</b>									
Turbo	8.87- 91		365053 				OE =		
<b>850</b>									
ALL ALL Exc.	(LS) (LW) 91- 97 92- 97	634908					344230 Exc.		 0,8
<b>940</b>									
ALL Exc. Turbo, Turbo -16V	90- 96	665055	365053 			444082	344056 Exc.	554054	 0,4
Turbo Exc. Turbo -16V	90- 96		365053 				344056 Exc.	554054	 0,4
Turbo -16V	90- 96		365053 				Exc.		
<b>960</b>									
ALL Exc. Turbo	90- 94	665055	365053 				OE =		
Turbo	90- 94		365053 				OE =		
ALL Exc. Turbo	90- 94	665055	365053 			444082	344056 Exc.	554054	 0,4
Turbo	90- 94		365053 				344056 Exc.	554054	 0,4
<b>Amazon</b>									
P 121, P 122, P 122 S, P 131, P 132	57- 70	443056		553020		443057		553021	
P 121, P 221	62- 70	443056				443058			
<b>P 142, P 144, P 145, P 164</b>									
P 142, P 144, P 164 + S P 145, P 145 S	66- 8.71 67- 8.71	443059				443060			
P 142, P 144, P 164 + S P 145, P 145 S	9.71- 8.74	443059	343011	553022		443061	343012	554020	

\*Excel-G is a new name of SUPER  
Excel-G ist der neue Name für SUPER  
Excel-G est le nom nouveau pour SUPER

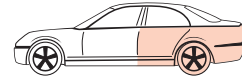
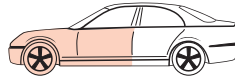

MODEL FAHRZEUG MODELE	YEAR JAHR ANNEE	FRONT/VORNE/AVANT				REAR/HINTEN/ARRIERE			
		PREMIUM Oil	EXCEL-G* Twin-tube Gas	GAS-A-JUST Mono-tube Gas		PREMIUM Oil	EXCEL-G* Twin-tube Gas	GAS-A-JUST Mono-tube Gas	
<b>Volvo (S)</b>									
<b>PV 444, PV 544, P 210</b>									
PV 444, PV 544	45- 66	443054				443055			
PV 445, P 210	57- 63	443054							
<b>S 40 , V 40 </b>									
Incl.  Sport sus. T4	5.95- 6.99 7.99-		334155 L 334154 R			341204 Exc.			
Sport sus. Incl.  Sport sus. T4	5.95- 6.99 7.99-		334175 L 334174 R			341217 Exc.			
<b>S70 , V70 , C70 </b>									
S70 ,  Exc. 2.5 Bifuel, 103kw, 2.5-20V Exc.	1.97-11.00	634908				344230 Exc.			
C70 ,  Exc.	3.97- 9.02	634908				344230 Exc.			
V70 ,  Exc. Exc. 2.0-20V Turbo AWD Exc. 2.5-20V Turbo AWD Exc. 2.3-20V T-5 AWD Exc. 2.3T AWD Exc. 2.5 Bifuel	1.97- 3.00	634908				344230 Exc.			
V70 , 2.0-20V Turbo AWD 2.5-20V Turbo AWD Exc.	1.97- 3.00	634908							
<b>S80 </b>									
2.0 2.0 T 2.4 2.8 T6 2.9 2.5 TDi Exc. , Self Leveling Exc. 3.0 T6, 2.4 D5	5.98-		334611					551918	
<b>S90 , V90 </b>									
S90 2.9 Exc. , Self Leveling	1.97- 5.98							551922	



MODEL FAHRZEUG MODELE	YEAR JAHR ANNEE	FRONT/VORNE/AVANT				REAR/HINTEN/ARRIERE			
		PREMIUM Oil	EXCEL-G* Twin-tube Gas	GAS-A-JUST Mono-tube Gas		PREMIUM Oil	EXCEL-G* Twin-tube Gas	GAS-A-JUST Mono-tube Gas	
<b>Volvo (S)</b>									
<b>S90  ,V90 </b>									
V90 2.9 Exc. , Self Leveling	1.97-12.98							551923	
<b>Wartburg (D)</b>									
 1000, 313, 353, 353 Tourist	57-	443145	343108	553133		443145	343108	553133	
Barkas	62- 65	443030	343049	554012		443030	343049	554012	
<b>Zastava (YU)</b>									
101/1100 		633004	333013			633005	333015		
Yugo 45, 55, 65	80-		333043			633005	333015		

\* Excel-G is a new name of SUPER  
 Excel-G ist der neue Name für SUPER  
 Excel-G est le nom nouveau pour SUPER